

TM 5-3810-306-10

TECHNICAL MANUAL

OPERATOR'S MANUAL FOR CONTAINER CRANE, 40 TON, ROUGH TERRAIN, MODEL RT875CC

NSN 3810-01-205-2716

and

ROUGH TERRAIN, MODEL RT875CCS

NSN 3810-01-497-1001

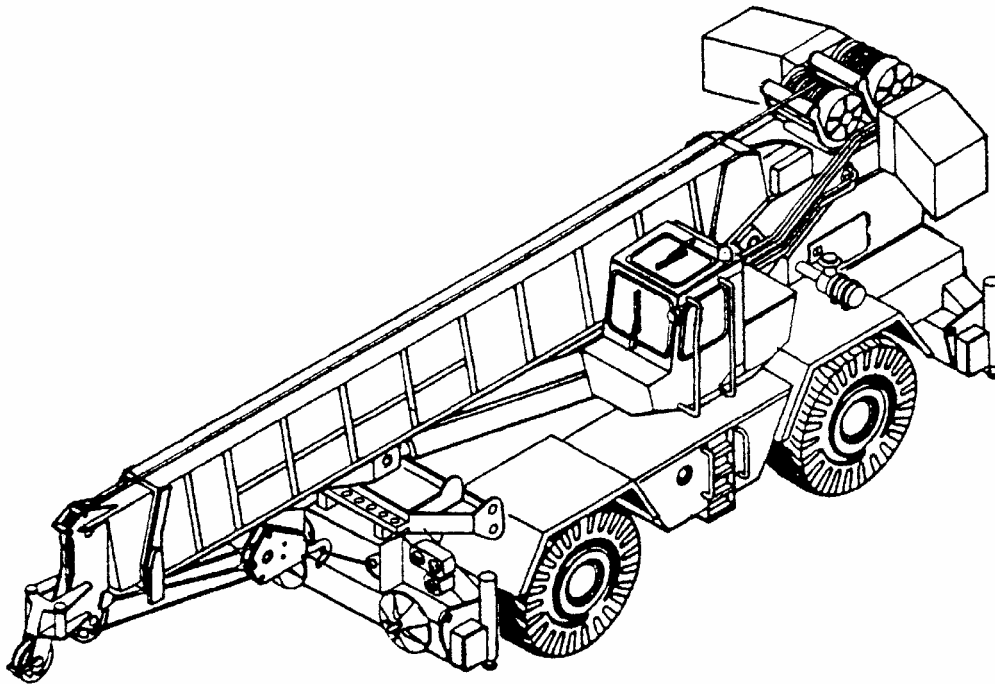

DISTRIBUTION STATEMENT A - Approved for public release; distribution is unlimited.

This manual supersedes TM 5-3810-306-10, dated 25 February 1993.

HEADQUARTERS, DEPARTMENT OF THE ARMY

FEBRUARY 2007

WARNING

OPERATIONS ADJACENT TO OVERHEAD LINES ARE PROHIBITED UNLESS ONE OF THE FOLLOWING CONDITIONS ARE SATISFIED.

1	POWER HAS BEEN SHUT OFF AND POSITIVE MEANS TAKEN TO PREVENT LINES FROM BEING ENERGIZED.	
2	POSITION AND BLOCK EQUIPMENT INSURING NO PARTS, INCLUDING CABLE, CAN COME WITHIN THE FOLLOWING CLEARANCES:	<p style="text-align: center;"><u>VOLTAGE REQD CLEARANCE</u></p> <p>UNDER 50 KV - 10 FEET</p> <p>69 KV - 12 FEET</p> <p>115-161 KV - 15 FEET</p> <p>230-285 KV - 20 FEET</p> <p>345 KV - 25 FEET</p> <p>500 KV - 35 FEET</p>

CHECK WITH YOUR LOCAL POWER SUPPLIER FOR CORRECT LINE VOLTAGE

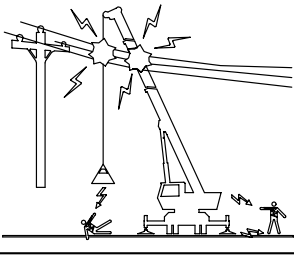

⚠ DANGER

ELECTROCUTION HAZARD

TO AVOID DEATH OR SERIOUS INJURY, KEEP ALL PARTS OF THIS CRANE, THE RIGGING, AND MATERIALS BEING LIFTED AT LEAST 20 FEET AWAY FROM ALL ELECTRICAL POWER LINES AND EQUIPMENT.

KEEP AWAY FROM THIS CRANE IF IT IS BEING OPERATED NEAR ELECTRICAL POWER LINES OR EQUIPMENT.

BEFORE OPERATING THIS CRANE IN THE VICINITY OF POWER LINES OR EQUIPMENT, NOTIFY THE POWER UTILITY COMPANY. HAVE POWER TURNED OFF.

FOLLOW INSTRUCTIONS IN OPERATOR'S AND SAFETY HANDBOOK.

7679002987

THIS CRANE IS NOT INSULATED.

NOTE

READ AND UNDERSTAND ALL OF THE SAFETY WARNINGS AND CAUTIONS CONTAINED IN CHAPTER 2 – OPERATING INSTRUCTIONS BEFORE OPERATING THE CRANE, DIRECT ANY QUESTIONS THAT YOU MAY HAVE TO YOUR SUPERVISOR FOR CLARIFICATION.

SAFETY SUMMARY

WARNING

BEFORE STARTING THE ENGINE, ENSURE THE PARKING BRAKE IS APPLIED AND SWING LOCK IS ENGAGED.

WARNING

AVOID OVERLOADING THE AIR BOX WHEN USING THE QUICK START BUTTON. DO NOT ATTEMPT MORE THAN THREE CONSECUTIVE STARTS WITHOUT ALLOWING THE QUICK START FLUID TO DISSIPATE. OTHERWISE, AN OVERLOADING OF THE AIR BOX WITH HIGHLY VOLATILE FLUID AND A MINOR EXPLOSION COULD OCCUR.

WARNING

ALWAYS SET THE PARKING BRAKE WHEN THE TRANSMISSION IS DISENGAGED.

WARNING

DO NOT DRIVE THE CRANE WITH THE BOOM OFF CENTER AS AUTOMATIC OSCILLATION LOCKOUT WILL OCCUR, MAKING THE CRANE SUBJECT TO TIPPING ON UNEVEN SURFACES.

DO NOT DRIVE THE CRANE WITH THE LIFT CYLINDERS BOTTOMED. POSITION THE BOOM TO HORIZONTAL.

WARNING

DO NOT TRAVEL WITH AN EMPTY HOOK IN A POSITION WHERE IT CAN SWING FREELY.

WARNING

IF NOT REQUIRED TO PERFORM AN ON-RUBBER LIFT, THE BOTTOM LIFT SLING MUST BE REMOVED FROM ITS ON CRANE STOWAGE CRADLE FOR ALL ON RUBBER LIFTS.

WARNING

WHEN PERFORMING AN ON-RUBBER LIFT AFTER MOVING THE CRANE, ALLOW THE TIRES TO COOL BEFORE LIFTING ANY LOADS WITH THE OUTRIGGERS RETRACTED. FAILURE TO FOLLOW THIS WARNING COULD RESULT IN A TIRE EXPLODING CAUSING PERSONNEL INJURY AND/OR EQUIPMENT DAMAGE.

WARNING

AVOID HOLES, ROCKS, AND EXTREMELY SOFT SURFACES, AND ANY OTHER OBSTACLES WHICH MIGHT SUBJECT THE CRANE TO UNDUE STRESSES OR POSSIBLE OVERTURN.

WARNING

ON OPEN GROUND, TOW OR PULL ONLY ON THE PINTLE HOOK OR LIFT LUGS.

WARNING

OPERATE THE REAR STEER ONLY FOR ADDED JOB SITE MANEUVERABILITY.

WARNING

ENSURE THE SWING LOCK AND THE SWING BRAKE ARE ENGAGED BEFORE STARTING EXTENDED TRAVELING.

WARNING

THE ENGINE MUST BE SHUT DOWN BEFORE ATTEMPTING TO ENGAGE THE HYDRAULIC PUMP DRIVE.

WARNING

THE OUTRIGGERS MUST BE FULLY EXTENDED AND SET BEFORE ANY OTHER OPERATION OF THE CRANE IS ATTEMPTED, UNLESS LIFTING ON RUBBER.

WARNING

EACH OUTRIGGER FLOAT WEIGHTS APPROXIMATELY 90 POUNDS (40.8 KG). USE TWO PEOPLE TO CAREFULLY REMOVE AND INSTALL EACH OUTRIGGER FLOAT ON MOUNTING STUDS.

KEEP FEET AND HANDS CLEAR OF THE OUTRIGGER FLOATS WHEN UNLOCKING THEM FROM THE STABILIZERS.

WARNING

BEFORE INITIATING ANY SWING OPERATIONS, MAKE CERTAIN THE AREA IN THE SWING PATH OF THE HOOK AND/OR LOAD (AS WELL AS THE TAIL SWING AREA), IS CLEAR OF ALL OBSTRUCTIONS AND PERSONNEL.

WARNING

WHEN SWINGING THE LOAD FROM OVER-THE-FRONT TO OVER-THE-SIDE, CHECK THE LOAD CHART TO MAKE CERTAIN THE APPLICABLE CAPACITY IS NOT EXCEEDED. TRAVELING WITH ANY LOAD OVER-THE-SIDE IS PROHIBITED.

WARNING

IF THE "ELEVATE BOOM" MESSAGE APPEARS ON THE LED ALERT DISPLAY DURING SWING, STOP SWING IMMEDIATELY AND ELEVATE THE BOOM TO CLEAR THE ENGINE HOOD.



WARNING

DO NOT OPERATE THE CRANE WITH A WORN OR DAMAGED HOIST ROPE.

WARNING

BEFORE ELEVATING THE BOOM, ENSURE THE AREA ABOVE AND BENEATH THE BOOM IS CLEAR OF ALL OBSTRUCTIONS AND PERSONNEL.

WARNING

BEFORE LOWERING THE BOOM, MAKE CERTAIN THE AREA BENEATH THE BOOM IS CLEAR OF ALL OBSTRUCTIONS AND PERSONNEL. WHEN LOWERING THE BOOM, LET OUT THE CABLE(S) SIMULTANEOUSLY TO PREVENT TWO-BLOCKING THE BOOM NOSE AND THE HOOK BLOCK(S).

WARNING

CHECK THE LOAD CHART FOR MAXIMUM LOAD AT GIVEN RADIUS, BOOM ANGLE AND LENGTH BEFORE EXTENDING BOOM WITH A LOAD.

WARNING

WHEN RETRACTING THE BOOM, THE LOAD WILL LOWER UNLESS THE CABLE IS TAKEN IN SIMULTANEOUSLY.

WARNING

BEFORE EXTENDING THE BOOM, MAKE CERTAIN THE AREA BEYOND THE BOOM IS CLEAR OF ALL OBSTRUCTIONS AND PERSONNEL. WHEN EXTENDING THE BOOM, THE LOAD WILL RAISE UNLESS THE CABLE IS LET OUT. LET OUT THE CABLE(S) SIMULTANEOUSLY TO PREVENT TWO-BLOCKING THE BOOM NOSE AND THE HOOK BLOCK(S).

WARNING

PROPERLY LEVEL THE CRANE PRIOR TO LIFTING ANY LOADS. A CRANE ONLY SLIGHTLY OUT-OF-LEVEL CAN QUICKLY ENCOUNTER A TIPPING CONDITION CAUSING PERSONNEL INJURY AND/OR EQUIPMENT DAMAGE.

WARNING

ALL LIFTING OPERATIONS SHOULD BE PERFORMED PROPERLY USING ONLY CORRECTLY RATED SLINGS OR OTHER RIGGING DEVICES. NEVER WRAP THE HOIST CABLE AROUND A LOAD. CHECK ALL TACKLE, HARDWARE, AND SLINGS BEFORE USE. REFUSE TO USE FAULTY EQUIPMENT.

WARNING

BEFORE LOWERING OR RAISING THE CABLE (LOAD), ENSURE THE AREA ABOVE AND/OR BENEATH THE LOAD IS CLEAR OF ALL OBSTRUCTIONS AND PERSONNEL.

WARNING

WHEN PAYING OUT HOIST CABLE, ALWAYS LEAVE A MINIMUM OF THREE WRAPS ON THE HOIST DRUM FOR SAFETY.

WARNING

NEVER PARK THE CRANE NEAR HOLES OR ON ROCKY OR EXTREMELY SOFT SURFACES. THIS MAY CAUSE THE CRANE TO OVERTURN, RESULTING IN INJURY TO PERSONNEL

WARNING

BEFORE LEAVING THE CRANE, ENSURE THE SWING LOCK AND THE SWING BRAKE ARE BOTH ENGAGED.

WARNING

FOLLOW STANDARD SAFETY PRECAUTIONS WHEN REFUELING. FUEL IT SAFELY.

WARNING

BE CAREFUL WHEN CHECKING THE COOLANT LEVEL. SHUT DOWN THE ENGINE AND ALLOW THE RADIATOR TIME TO COOL BEFORE REMOVING THE RADIATOR CAP.

WARNING

ALWAYS SOUND THE HORN TO ALERT PERSONNEL IN THE AREA BEFORE SWINGING THE BOOM.

WARNING

ALLOW NO ONE OTHER THAN THE OPERATOR TO BE ON THE CRANE WHILE THE CRANE IS FUNCTIONING OR MOVING.

WARNING

WHEN INFLATING OR ADDING AIR TO THE TIRES, USE A TIRE CAGE AND SCREW-ON-INFLATOR. ALSO USE AN EXTENSION HOSE WHICH WILL PERMIT STANDING BEHIND THE TIRE TREAD WHEN INFLATING.

WARNING

DO NOT MIX BIAS-PLY AND RADIAL-PLY TIRES.

WARNING

BE CAREFUL WHEN CHECKING EXHAUST SYSTEM COMPONENTS. SHUT DOWN THE ENGINE AND ALLOW THE COMPONENTS TIME TO COOL.

WARNING

BE CAREFUL WHEN CHECKING BOOM SHEAVES AND HOOK BLOCK. DO NOT TOUCH SHEAVE EDGE.

WARNING

BE CAREFUL WHEN CHECKING OPERATION OF THE LMI SYSTEM. USE CARE TO PREVENT DAMAGE TO THE CRANE OR INJURY TO PERSONNEL. IF THE CRANE OPERATOR CANNOT SEE THE

LOAD HANDLING DEVICE (HOOK BLOCK AND/OR BOTTOM LIFT SLING), USE A SPOTTER TO MONITOR THE LOAD HANDLING DEVICE. THE CRANE OPERATOR SHOULD BE PREPARED TO STOP OPERATION IMMEDIATELY SHOULD THE LMI NOT FUNCTION PROPERLY TO LOCKOUT AN UNSAFE CONDITION.

WARNING

NEVER LEAVE CRANE WITH A LOAD SUSPENDED. SHOULD IT BECOME NECESSARY TO LEAVE THE CRANE, LOWER LOAD TO GROUND AND STOP ENGINE BEFORE LEAVING CAB.

WARNING

ELECTRICITY CAN CAUSE SEVERE INJURY OR DEATH IF CONTACT OCCURS.

WARNING

PINCH POINTS ARE IMPOSSIBLE TO ELIMINATE. KEEP ALL PORTIONS OF YOUR BODY AWAY FROM CABLE DRUMS, SHEAVES, PULLEYS, LIFT CYLINDERS, AND OTHER MOVING PARTS OF THE CRANE. BE EXTREMELY CAREFUL WHEN PERFORMING MAINTENANCE ON THE CRANE.

WARNING

NEVER HANDLE WIRE ROPE WITH BARE HANDS.

WARNING

ASSUME ALL POWER SOURCES ARE ELECTRICALLY ENERGIZED ("HOT" OR "LIVE") UNTIL YOU HAVE ABSOLUTELY RELIABLE INFORMATION TO THE CONTRARY.

WARNING

LOAD CHARTS REPRESENT THE ABSOLUTE MAXIMUM ALLOWABLE LOADS WHICH ARE BASED ON EITHER TIPPING OR STRUCTURAL LIMITATIONS UNDER SPECIFIC CONDITIONS. KNOWING THE PRECISE RADIUS OF OPERATION, BOOM LENGTH, AND ANGLE SHOULD BE A PART OF YOUR ROUTINE PLANNING AND OPERATION. ACTUAL LOADS, INCLUDING NECESSARY ALLOWANCES, SHOULD BE KEPT BELOW THESE CAPACITY FIGURES.

WARNING

THIS CRANE IS NOT EQUIPPED WITH ANY ELECTRICAL WARNING OR INSULATING DEVICES. EXTREME CAUTION MUST BE EXERCISED BY ALL PERSONNEL WORKING WITH AND AROUND THIS CRANE WHEN NEAR AN ENERGIZED POWER SOURCE OR POWER LINES.

WARNING

TEST RESULTS HAVE INDICATED STEADY STATE NOISE LEVELS OF 85dB(A) AND GREATER, AT GOVERNED ENGINE RPM, DURING CRANING OPERATIONS. THE MAXIMUM LEVEL OF 89dB(A) OCCURS AT THE OPERATOR'S STATION WITH THE DOORS CLOSED AND DECREASES TO 85dB(A) AT THE ENVELOPE CONTOUR SHOWN. OUTSIDE THIS CONTOUR THE LEVEL IS BELOW 85dB(A).

WITHIN THE 85dB(A) ENVELOPE HEARING PROTECTION IS REQUIRED. HEARING PROTECTION DEVICES MUST

REDUCE THE NOISE REACHING THE AUDITORY SYSTEM TO A LEVEL BELOW 85dB(A). THESE DEVICES INCLUDE EAR PLUGS, EAR MUFFS, ATTENUATING HELMETS, AND HEADSETS PROVIDED THEY ARE APPROVED BY THE SURGEON GENERAL OF THE UNITED STATES.

PHYSICAL HARM WHICH CAN RESULT FROM UNSAFE OPERATION OF THIS EQUIPMENT IS NOT RESTRICTED TO THOSE WHICH ARE VISIBLE. THE PURPOSE OF THE HEARING PROTECTION REQUIREMENT IS TO CONSERVE THE HEARING OF PERSONNEL. OBSERVE THIS NOTICE AND THE POSTED CAUTION DECALS ON THE CRANE AND USE HEARING PROTECTION WHERE REQUIRED.

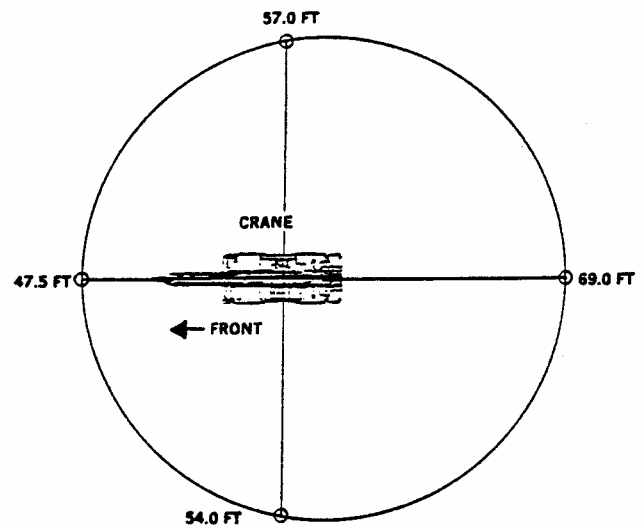

Hearing Protection Required

WARNING

DO NOT USE AEROSOL SPRAY OR OTHER TYPES OF STARTING FLUIDS CONTAINING ETHER / VOLATILES THAT CAN CAUSE EXPLOSIONS OR FIRE.

WARNING

THE LMI SYSTEM IS AN OPERATIONAL AID ONLY.

THE DEVICE IS NOT, AND SHALL NOT BE, A SUBSTITUTE FOR GOOD OPERATOR JUDGEMENT, EXPERIENCE AND USE OF ACCEPTED SAFE CRANE OPERATING PROCEDURES.

THE RESPONSIBILITY FOR THE SAFE OPERATION OF THE CRANE SHALL REMAIN WITH THE CRANE OPERATOR WHO SHALL ENSURE THAT ALL WARNINGS AND INSTRUCTIONS SUPPLIED ARE FULLY UNDERSTOOD AND OBSERVED.

PRIOR TO OPERATING THE CRANE, THE OPERATOR MUST CAREFULLY AND THOROUGHLY READ AND UNDERSTAND THE INFORMATION IN THIS MANUAL TO ENSURE THAT HE KNOWS THE OPERATION AND LIMITATIONS OF THE INDICATOR AND CRANE.

WARNING

THE CRANE IS EQUIPPED WITH AN ANTI-TWO BLOCK WARNING SYSTEM. ENSURE THAT BOTH ANTI-TWO BLOCK SWITCHES ARE FUNCTIONAL PRIOR TO OPERATING THE CRANE. FAILURE TO FOLLOW THIS PROCEDURE COULD RESULT IN PERSONAL INJURY AND EQUIPMENT DAMAGE.

USE THE RED BY-PASS FLAG (PLUG) TO DISABLE/DEACTIVATE AN ANTI-TWO BLOCK SWITCH ONLY IF WIRE ROPE AND LOAD-HANDLING DEVICE HAVE BEEN REMOVED ON A PARTICULAR BOOM NOSE (MAIN OR AUXILIARY). BE SURE TO REMOVE THE RED FLAG WHEN THE WIRE ROPE AND LOAD HANDLING DEVICE HAVE BEEN REINSTALLED.

WARNING

RT875CCS ONLY: SETTING THE OPERATIONAL MODE OF THE LMI SYSTEM IS CRITICAL TO THE PROPER OPERATION OF THE LMI SYSTEM AND THE CRANE. THEREFORE, ONLY EXPERIENCED/ TRAINED OPERATORS SHOULD SELECT LMI OPERATION MODE.

WARNING

RT875CCS ONLY: SINCE THE “BY-PASS A2B” AND “BY-PASS LMI” BUTTONS AND CONTROL LIGHTS, LOCATED ON THE LMI DISPLAY CONSOLE, DEACTIVATE THE CUT-OFF FUNCTION OF THE LMI SYSTEM/ ANTI TWO-BLOCK SYSTEM, THE FOLLOWING INSTRUCTIONS MUST BE OBEYED:

1. THE BY-PASS FUNCTION SHALL BE USED ONLY WITH COMMAND AUTHORIZATION, AS UNWARRANTED USE OF IT TO OVERRIDE THE LMI CONTROL LEVER LOCKOUT SYSTEM CAN RESULT IN HARM TO THE CRANE AND DANGER TO PROPERTY AND PERSONNEL.
2. NEVER USE THE BY-PASS FUNCTION TO EITHER OVERLOAD OR OPERATE THE CRANE IN AN UNSAFE CONDITION.

WARNING

RT875CC ONLY: SELECTING THE CORRECT NUMBER OF LINE PARTS USING THE REEVING SELECTOR SWITCH ON THE LOAD MOMENT INDICATOR IS CRITICAL TO THE OPERATION OF THE LOAD MOMENT INDICATOR SYSTEM. SELECTING THE WRONG NUMBER WILL RESULT IN FAULTY INDICATIONS AND POSSIBLE PERSONNEL INJURY OR EQUIPMENT DAMAGE.

WARNING

RT875CC ONLY: ENSURE THAT WHEN PERFORMING CRANING OPERATIONS ON RUBBER (I.E. WITHOUT EXTENDING THE OUTRIGGERS) THE "ON OUTRIGGERS/ON RUBBER" SELECTOR SWITCH ON THE LOAD MOMENT INDICATOR IS SET TO "ON RUBBER." OTHERWISE THE LOAD MOMENT INDICATOR WILL SHOW CRANING VALUES THAT ARE NOT ACCURATE. FAILURE TO FOLLOW THIS PROCEDURE COULD RESULT IN PERSONNEL INJURY AND/OR EQUIPMENT DAMAGE

WARNING

RT875CC ONLY: ENSURE THAT WHEN PERFORMING PICK AND CARRY OPERATIONS (I.E. MOVING THE CRANE WHILE LIFTING A LOAD) THE "STATIONARY/PICK & CARRY" SELECTOR SWITCH ON THE LOAD MOMENT INDICATOR IS SET AT "PICK & CARRY." OTHERWISE, THE LOAD MOMENT INDICATOR WILL SHOW CRANING VALUES THAT ARE NOT ACCURATE. FAILURE TO FOLLOW THESE PROCEDURES COULD RESULT IN PERSONNEL INJURY AND/OR EQUIPMENT DAMAGE

WARNING

THIS VEHICLE HAS BEEN DESIGNED TO OPERATE SAFELY AND EFFICIENTLY WITHIN LIMITS SPECIFIED IN THIS TM. OPERATIONS BEYOND THESE LIMITS ARE PROHIBITED IN ACCORDANCE WITH AR 70-1 WITHOUT WRITTEN APPROVAL FROM: COMMANDER, U.S. ARMY TANK-AUTOMOTIVE AND ARMAMENT COMMAND, ATTN: SFEA-CSS-FP-C, WARREN, MI 48397-5000.

WARNING

RT875CC ONLY: BEFORE USING THE "CLL-OVERRIDE" MOMENTARY SELECTION SWITCH ON THE LOAD MOMENT INDICATOR, BE AWARE THAT YOU ARE DISABLING A SAFETY DEVICE, THE AUTOMATIC CONTROL LEVER LOCKOUT SYSTEM. DO NOT ASSUME THAT SAFETY DEVICES INSTALLED ON THIS CRANE HAVE FAILED WHEN CRANING OPERATIONS "APPEAR" TO BE WITHIN CRANE OPERATING CAPACITIES WHEN THE ALARM OCCURS - INVESTIGATE FIRST! FAILURE TO OBSERVE THIS WARNING COULD RESULT IN PERSONNEL INJURY AND/OR EQUIPMENT DAMAGE.

WARNING

DO NOT EXTEND OR LOWER THE BOOM WHEN LOWERING A SUSPENDED LOAD TO THE GROUND USING THE EMERGENCY STOWAGE PROCEDURES.

WARNING

RT875CCS ONLY: FOLLOW EMERGENCY STOWAGE PROCEDURES PROPERLY. FAILURE TO FOLLOW PROCEDURES COULD RESULT IN DEATH OR SERIOUS INJURY.

WARNING

BEFORE STARTING ANY TROUBLESHOOTING PROCEDURES PLEASE WEAR THE PROPER EYE PROTECTION IN ORDER TO INSURE PERSONAL SAFETY.

WARNING

BE SURE YOU ARE WEARING THE PROPER EYE PROTECTION DEVICES BEFORE STARTING MAINTENANCE PROCEDURES IN ORDER TO INSURE PERSONAL SAFETY.

WARNING

DUE TO HIGHWAY REQUIREMENT OF NON-PERMANENTLY ATTACHED COMPONENTS AND ITEMS, THE BOTTOM LIFT SLING MUST BE REMOVED FROM THE ON BOARD STORAGE CRADLE AND SHIPPED SEPARATELY IN THE STOWAGE TRAY PROVIDED WITH THE BOTTOM LIFT SLING BEFORE TRANSPORTING THE CRANE (SEE APPENDIX G).

TM 5-3810-306-10

INSERT LATEST CHANGED PAGES. DESTROY SUPERCEDED DATA.

LIST OF EFFECTIVE PAGES

NOTE: The portion of text affected by the changes is indicated by a vertical line in the outer margins of the pages. Changes to illustrations are also indicated by vertical lines in the outer margins.

Dates of issue for original and changed pages are:

Original ..0.. 28 FEBRUARY 2007

**TOTAL NUMBER OF PAGES FOR THIS MANUAL IS 184
CONSISTING OF THE FOLLOWING:**

Page No.	*Change No.	Page No.	*Change No.	Page No.	*Change No.
Cover	0				
Blank	0				
a thru j	0				
i – ii	0				
1-1 – 1-14	0				
2-1 – 2-66	0				
3-1 – 3-22	0				
A-1 – A-4	0				
B-1 – B-4	0				
C-1 – C-2	0				
D-1 – D-4	0				
E-1 – E-22	0				
F-1 – F-14	0				
G-1 – G-10	0				
H-1 – H-2	0				
Index-1 thru Index-6	0				

* Zero in this column indicates an original page.

TECHNICAL MANUAL
OPERATOR'S MANUAL FOR
CONTAINER CRANE, 40-TON,
ROUGH TERRAIN, MODEL RT875CC
NSN 3810-01-205-2716
and
ROUGH TERRAIN, MODEL RT875CCS
NSN 3810-01-497-1001

REPORTING ERRORS AND RECOMMENDING IMPROVEMENTS

You can help improve this publication. If you find any mistakes or if you know of a way to improve the procedures, please let us know. Submit your DA Form 2028 (Recommended Changes to Publications and Blank Forms), through the Internet, on the Army Electronic Product Support (AEPS) website. The Internet address is <http://aeeps.ria.army.mil>. If you need a password, scroll down and click on "ACCESS REQUEST FORM". The DA Form 2028 is located in the ONLINE FORMS PROCESSING section of the AEPS. Fill out the form and click on SUBMIT. Using this form on the AEPS will enable us to respond quicker to your comments and better manage the DA Form 2028 program. You may also mail, fax or E-mail your letter or DA Form 2028 direct to: AMSTA-LC-LPIT Tech Pubs, TACOM-RI, 1 Rock Island Arsenal, Rock Island, IL 61299-7630. The email address is ROCK-TACOM-TECH-PUBS@conus.army.mil. The fax number is DSN 793-0726 or Commercial (309) 782-0726.

TABLE OF CONTENTS	Page
CHAPTER 1 INTRODUCTION	1-1
Section I General Information	1-1
Section II Equipment Description	1-2
Section III Technical Principles of Operation	1-11
CHAPTER 2 OPERATING INSTRUCTIONS	2-1
Section I Description and Use of Operator's Controls and Indicators	2-1
Section II Preventive Maintenance Checks and Services	2-16
Section III Operation Under Usual Conditions	2-32
Section IV Operation Under Unusual Conditions	2-57
CHAPTER 3 MAINTENANCE INSTRUCTIONS	3-1
Section I Lubrication Instructions	3-1
Section II Troubleshooting Procedures	3-1
Section III Maintenance Procedures	3-18
APPENDIX A REFERENCES	A-1
APPENDIX B COMPONENTS OF END ITEM AND BASIC ISSUE ITEMS LISTS	B-1
Section I Introduction	B-1
Section II Components of End Item List	B-2
Section III Basic Issue Items List	B-4

Approved for public release; distribution is unlimited.
This manual supersedes TM 5-3810-306-10, dated 25 February 1993.

	Page
APPENDIX C ADDITIONAL AUTHORIZATION LIST	C-1
Section I Introduction	C-1
Section II Additional Authorization List	C-2
APPENDIX D EXPENDABLE SUPPLIES AND MATERIALS LIST	D-1
Section I Introduction	D-1
Section II Expendable Material List	D-2
APPENDIX E STOWAGE AND SIGN GUIDE	E-1
APPENDIX F LOAD CHART	F-1
APPENDIX G OPERATION AND STOWAGE OF BOTTOM LIFT SLING, 20 FT / 40 FT SELF LEVELING	G-1
APPENDIX H TRANSPORTABILITY GUIDANCE.....	H-1
ALPHABETICAL INDEX	I-1

CHAPTER 1 - INTRODUCTION

Section I - GENERAL INFORMATION

SCOPE

Type of Manual

This Operator's Manual provides information for the operation of the Container Crane, Rough Terrain, Wheel Mounted, Hydraulic, Diesel Powered, Models RT875CC and RT875CCS. The RT875CCS is an RT875CC which has been subjected to a Service Life Extension Program (SLEP). For the RT875CCS, the vehicle's data plates have been stamped with an "R" at the end of the serial number to show that it has gone through rebuild.

NOTE

Throughout this manual, reference is made to left, right, front and rear when describing locations. These reference locations are to be considered as those viewed from the operator's seat with the boom facing forward over the front of the carrier frame.

Purpose of Equipment

The crane is used to pick and position 40-foot ISO containers within a 22-foot load radius and 20-foot ISO containers within a 27-foot load radius at U.S. Army supply depots.

Special Limitations on Equipment

Refer to the Load Chart, Appendix F.

MAINTENANCE FORMS, RECORDS, AND REPORTS

Department of the Army forms and procedures used for equipment maintenance will be those prescribed by DA PAM 738-750, The Army Maintenance Management System. Accidents involving injury to personnel or damage to material will be reported on DA Form 285 (Accident Report) in accordance with AR385-40. Explosives and ammunition malfunctions will be reported in accordance with AR75-1.

REPORTING EQUIPMENT IMPROVEMENT RECOMMENDATIONS (EIR)

If your Container Crane needs improvement, let us know. Send us an EIR. You, the user, are the only one who can tell us what you don't like about your equipment. Let us know why you don't like the design. Put in on an SF 368 (Quality Deficiency Report). Mail it to us at U.S. Army Tank-Automotive and Armament Command, ATTN: AMSTA-AC-NML, Rock Island, Illinois 61299-7630. We'll send you a reply.

EQUIPMENT IMPROVEMENT REPORT AND MAINTENANCE DIGEST (EIR MD).

The quarterly Equipment Improvement Report and Maintenance Digest, TB 43-0001-39 series, contains valuable field information on the equipment covered in this manual. The information in the TB 43-0001-39 series is compiled from some of the Equipment Improvement Reports that you prepared on the vehicles covered in this manual. Many of these articles result from comments, suggestions, and improvement recommendations that you submitted to the EIR program. The TB 43-0001-39 series contains information on equipment improvements, minor alterations, proposed Modification Work Orders (MWOs) warranties (if applicable), actions taken on some of your DA Forms 2028-2 (Recommended Changes to Publications), and advance information which will help you in doing your job better and will help in keeping you advised of the latest changes to this manual. Also refer to Appendix A, References, of this manual.

WARRANTY INFORMATION

The Container Crane (RT875CC) was warranted by the manufacturer for 12 months. It started on the date, found in block 23, DA Form 2408-9, in the logbook. Report all defects in material or workmanship to your supervisor, who will take appropriate action through your organizational maintenance shop. Refer to Warranty Technical Bulletin TB 5-3810-306-14.

Section II - EQUIPMENT DESCRIPTION

EQUIPMENT CHARACTERISTICS, CAPABILITIES AND FEATURES

The crane is fully self-contained. All functions are either electrically or hydraulically controlled and hydraulically operated. Main functions include:

- a. Raising and lowering the boom.
- b. Extending and retracting the boom.
- c. Raising and lowering loads with the hoist(s).
- d. Swinging the boom.
- e. Extending and retracting the outrigger beams and stabilizers.

A diesel engine provides drive power for the hydraulic pumps and also drives a compressor and an alternator which supply air and electrical power for control, accessory and lighting systems. The engine also provides power to the axles through a remote mounted, six-speed (forward and reverse) transmission to drive the crane. Planetary drive axles provide four-wheel drive. Axle steering is accomplished through hydraulic steer cylinders.

The carrier frame features an integral fifth wheel, to which the rear axle is mounted, to allow the axle to pivot. Axle pivot lockout is automatic when the superstructure rotates more than five degrees in either direction from its straight ahead position. The carrier frame has towing lugs located front and rear.

Air and hydraulic flow and electrical power are transferred from the carrier frame to the superstructure by swivels located at the center of rotation. Hydraulic cylinders activate the elevation, telescope and outrigger systems.

The hoist and swing systems are driven by hydraulic motors.

The superstructure is capable of 360-degree continuous rotation in either direction. The crane is equipped with a two-section boom. Lifting is provided by a main hoist and an auxiliary hoist.

The vehicle fording capability is sixty (60) inches.

SLEP MODIFICATIONS

The following is a list of the major changes/system improvements that were effected by the SLEP.

1. Upgraded Load Moment Indicating System,
2. Improved Emergency Load Lowering/ Emergency Steering System,
3. Bottom Lift Sling Stowage Brackets,
4. Additional Boom Floodlight and New Cab Area Work Light,
5. Hoist Mirrors Added,
6. Improved Steps/Carrier Deck Access,
7. New Batteries and Battery Cables and Battery Disconnect Added,
8. Low Temperature Hydraulic Hoses and O-rings,
9. New Cab Heater,
10. Improved Decals and New Load Chart, and
11. New In-Line Fuel Heater/Water Separator.
12. New main boom nose wire rope wedge socket.

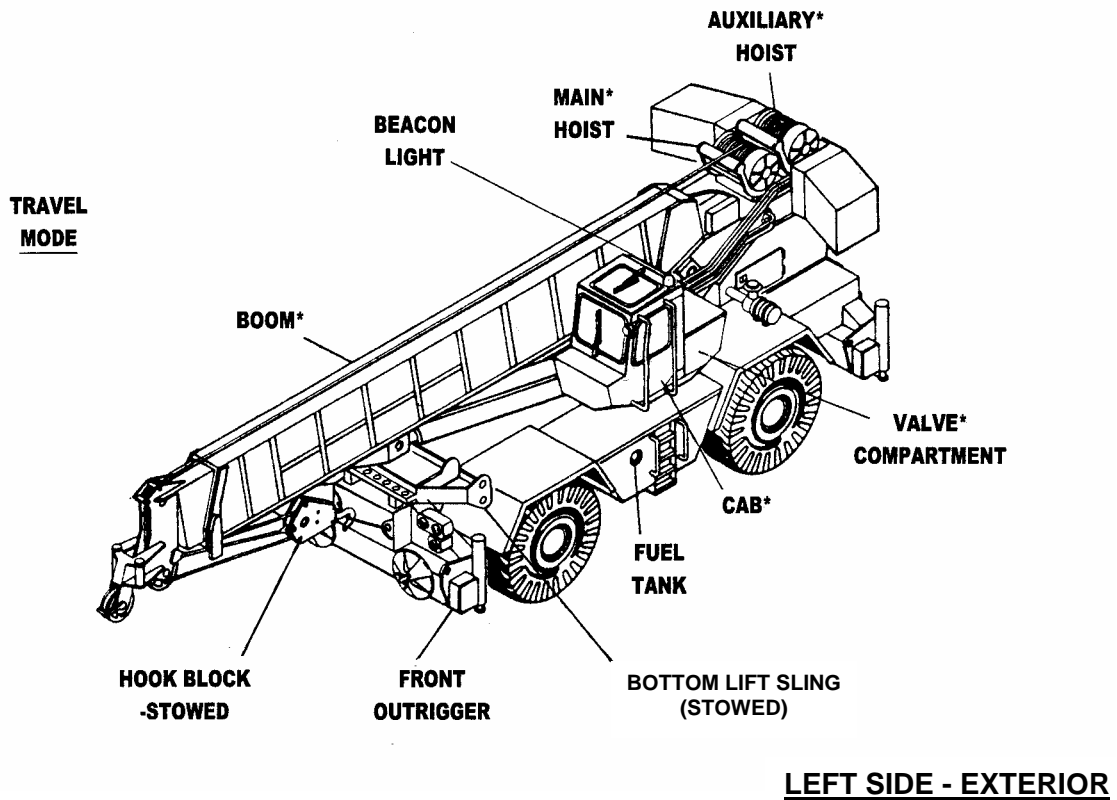
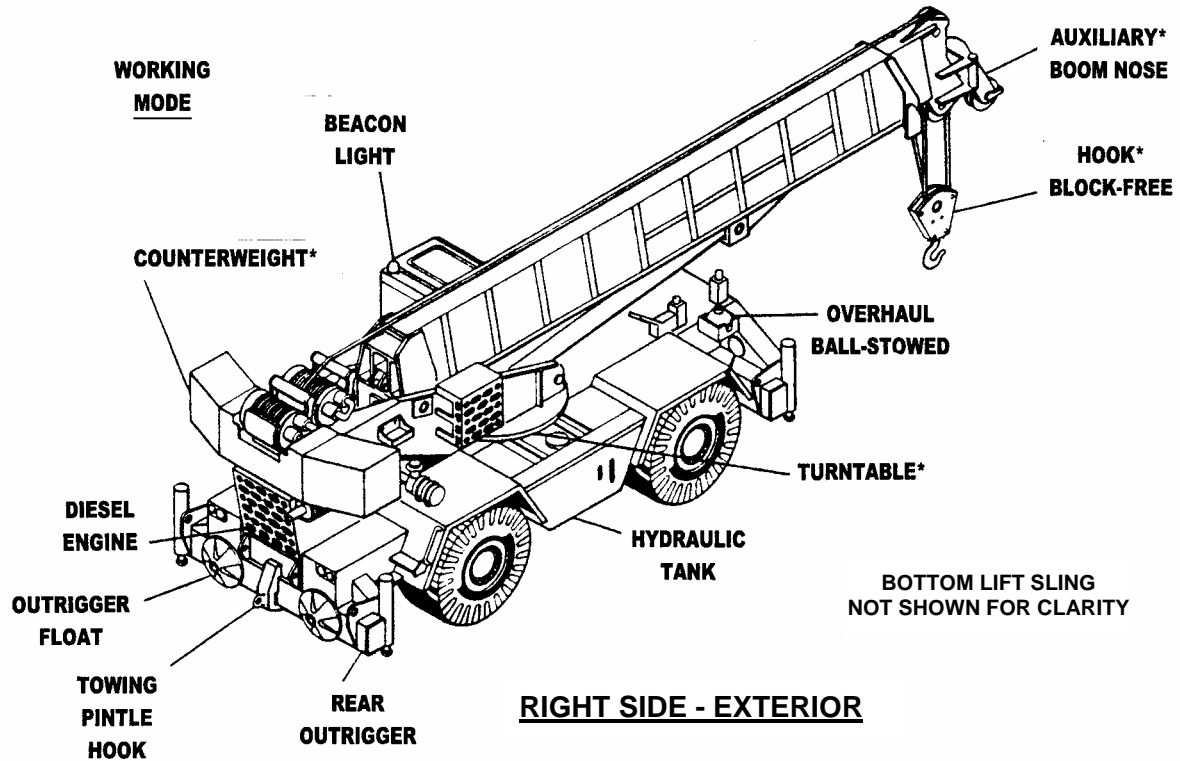

RT875CCS

NOTE: Items marked * form the crane's superstructure

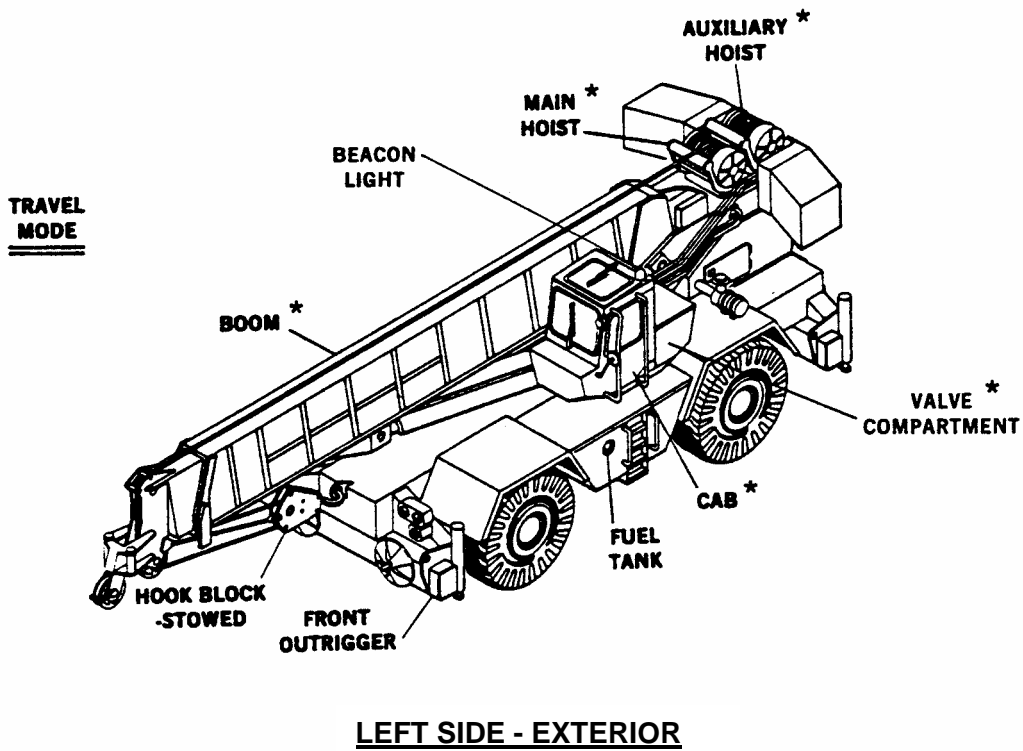
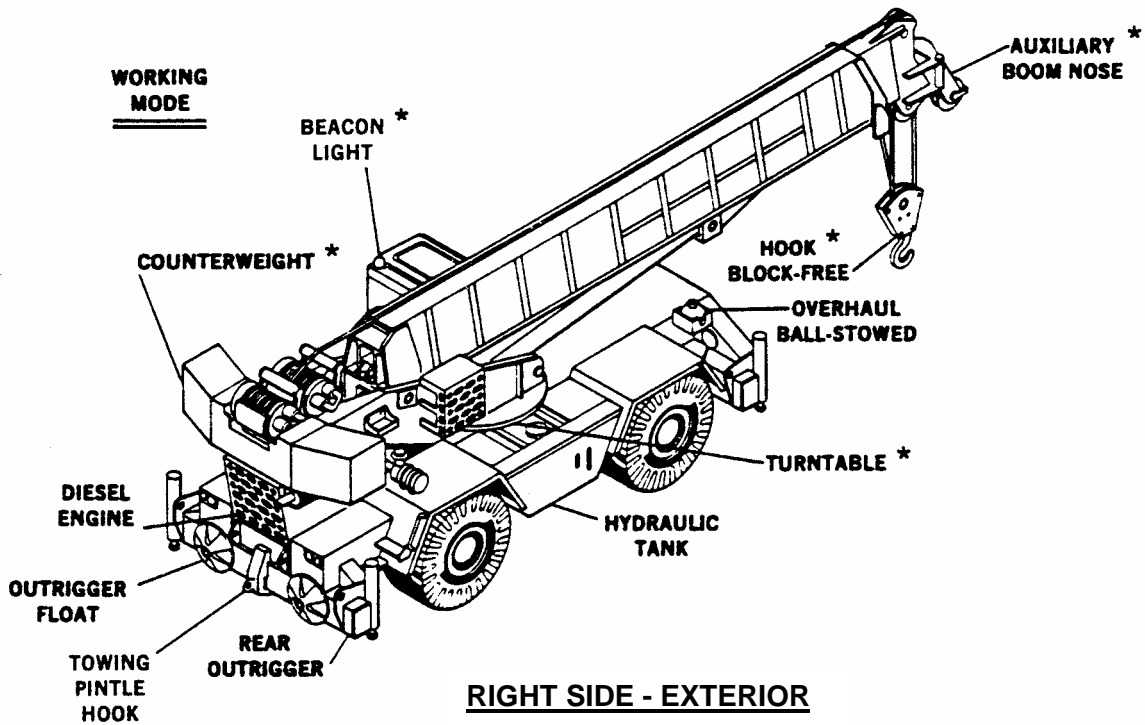

RT875CC

NOTE: Items marked * form the crane's superstructure

LOCATION AND DESCRIPTION OF MAJOR COMPONENTS

Cab Assembly

The cab is all-steel, acoustically-treated, and fully-enclosed with tinted safety glass window. It contains all engine and crane controls and indicators for complete operation of the crane including outrigger controls. The cab also contains an operator's seat, heater, defroster, electric windshield wiper, dome light and fire extinguisher.

Engine

A diesel engine is housed in a compartment at the rear of the frame. The engine provides crane mobility, drives the hydraulic pumps, charges the air system via the compressor, and drives the alternator.

Fuel Tank

A 100-gallon (378-liter) capacity fuel tank is mounted on the left side of the frame between the axles. The filler cap, located on the side of the tank, is accessible from ground level.

Torque Converter

The torque converter is mounted on and driven by the engine. It drives the three-section hydraulic pump, the two-section hydraulic pump, and the converter/transmission charging pump.

Transmission

The transmission is a powershift six-speed (forward and reverse) type. The transmission is mounted on the carrier frame near the center of the crane.

Axles

The front and rear axles are drive and steer (axles) with brakes at all four wheels.

Hydraulic Reservoir

The hydraulic reservoir is located on the right side of the carrier. The reservoir contains hydraulic system oil and includes a filter and by-pass valve.

Turntable Assembly and Swing Mechanism

An anti-friction roller bearing supports the superstructure on the carrier frame allowing 360 degrees continuous rotation (swing) in either direction. The bearing is driven by a hydraulic motor and gear reducer/brake arrangement mounted above the bearing in the turntable.

Boom Assembly

The two-section boom extends from 34.4 to 60.4 feet (10.52 to 18.46 meters). The boom is mounted on a turntable and is raised/lowered and extended/retracted by hydraulic cylinders.

Auxiliary Boom Nose

The auxiliary boom nose consists of a welded extension with a sheave assembly. The auxiliary boom nose is mounted on the boom nose.

Main Hoist

The main hoist provides power for all load raising and lowering operations. The main hoist is mounted at the rear of the boom on the turntable.

Auxiliary Hoist

The auxiliary hoist provides power for all load raising and lowering operations when the auxiliary boom nose is installed and the overhaul ball is being used. The auxiliary hoist is mounted on the counterweight.

Outriggers

The outriggers consist of hydraulically-actuated, box-type beams and vertical jack cylinders, one at each corner of the crane. The outriggers provide a rigid, four-point platform capable of supporting the crane and its maximum load capacity.

Swivels

Air, electrical and hydraulic swivels route the air, transmission, electrical and hydraulic circuits from the superstructure to the carrier frame. These swivels are mounted as a single assembly above the turntable bearing and drive.

EQUIPMENT DATA

General

Grove Manufacturing Co. Model No. RT875CC
 Model No. RT875CCS

Rated Capacity See Load Chart, Appendix F

Drive 4 x 4

Gross Weight (RT875CC)..... 94,500 lbs (42,865 kg)

Gross Weight (RT875CCS) with bottom lift sling stowed..... 97,325 lbs (44,147 kg)

Gross Weight (RT875CCS) without bottom lift sling..... 95,800 lbs (43,455 kg)

Dimensions

NOTE

Dimensions listed are for a crane with all components fully retracted and in the travel mode.

Wheel Base 170 in. (431.8 cm)

Overall Crane Length 46.3 ft (14.1 m)

Overall Crane Width 144 in. (365.76 cm)

Overall Crane Height 156.75 in. (398.15 cm)

Tail-swing 171 in. (434.34 cm)

Curb Clearance Circle (4W Steer Mode) 50.2 ft (15.3 m)

Capacities

Fuel Tank 100 gal. (378.50 l)

Hydraulic Tank 165 gal. (624.52 l)

Coolant System 44 qts (41.6 l)

Engine Lubrication System 23.7 qts (22.42 l)

Hoists (each)..... 10 qts (9.46 l)

Swing Gearbox 15 qts (14.2 l)

Axle Planetary End 29 qts (27.45 l)

Axle Drive Unit 15 qts (14.2 l)

Transmission 34.4 qts (32.6 l)

Fire Extinguisher

Manufacturer..... Walter Kidde

Model 897213-10BC-23/4

Type Dry

Rating..... 10 BC

Weight..... 2.75 lbs (1.2 kg)

Engine

Manufacturer..... Cummins

Model 6CTA8.3

Type 6 cyl OHV, diesel

Combustion..... 4 cycle, turbo-charged, after-cooled

Bore and Stroke 4.49 in. x 5.32 in.
 (114 mm x 135 mm)

Displacement 504.5 cu in. (8.27 l)

Horsepower (Gross) 250

Engine (Continued)

Torque (Gross) 650 ft lbs @ 1800 rpm
 Cooling System 44 qts (41.6 l)
 Lube System 23.7 qts (22.5 l)
 Air Cleaner 2-stage, dry type
 RPM, Engine Idle 800 RPM
 RPM, Engine Full (Governed) 2500 RPM

Torque Converter

Manufacturer Clark
 Model C273.5
 Stall Torque Ratio 1.820:1
 Charge Pump 21 gpm (80 lpm)
 Pump Drive Ratio 0.95:1

Transmission

Manufacturer Clark
 Model R28661
 Speeds 6
 Gear Ratios 1 13.91:1
 2 6.58:1
 3 2.41:1
 4 4.84:1
 5 2.29:1
 6 0.84:1

Axles

Manufacturer Rockwell
 Model PSC 1794
 Rings and Pinion Ratio 5.287:1
 Planetary Ratio 5.200:1
 Total Overall Ratio 27:490:1

Wheels and Tires

Manufacturer Grove
 Model 6-970-001386
 Lugs 24
 Torque 300 to 330 lb ft (41.47 to 45.62 kgm)
 Tire Size 29.5 x 25
 Ply Rating 28

Brakes

Manufacturer Rockwell
 Model KDA-20004
 Type Operator Air
 Type Double Wedge

Steering Control Valve

Manufacturer..... Eaton
Model 211-1041-001
Displacement 47.5 cu in.
(778.69 cu cm) per revolution
Capacity 12 gpm (45.4 lpm)

Air Compressor

Manufacturer..... Cummins
Model 3051041
Number of Cylinders 1
Piston Displacement @ 1250 rpm 13.2 cfm (6230 cm³/sec)

Hydraulic Pumps

Manufacturer..... Commercial Shearing
Model - 3-section 313-9632-022
2-section 312-9320-536
Type Gear
Sections 1 - two section and 1 - three section
GPM..... 3 - 50 gpm (189 lpm) and
2 - 27 gpm (102.1 lpm)
@ 2400 rpm

Swing Motor

Manufacturer..... Char-Lynn
Model 101-1086
Type Gerotor
Displacement 17.9 cu in./rev. (293 cu cm)

Swing Gearbox

Manufacturer..... Grove
Model GB-200A
Type Gear Reduction
Reduction..... Ratio 20.2:1

Boom

Manufacturer Grove
Model (RT875CC) 2-187-910006
Model (RT875CCS) 2-187-900028
Length 34.4 - 60.4 ft
(10.5 - 18.4 m)
Elevation -4° to +80°

Main and Auxiliary Hoists

Manufacturer..... Grove
 Model HO 30E-16
 Drum Dimensions
 Diameter 16-in. (40.64 cm)
 Length..... 16-in. (40.64 cm)
 Cable Capacity With Cable Dia. Of..... 0.75 in. (19 mm)
 16 inch (40.64 cm) Drum. 525 ft (160 m)
 Permissible Line Pull..... Refer to the Line Pulls
 and Reeving Info Chart in the Cab

Counterweight

Manufacturer..... Grove
 Model 2-187-200063
 Type Fixed-Bolted On
 Weight..... 12,500 lbs (5,670 k)

Outriggers

Manufacturer..... Grove
 Model (RT875CC) 2-187-100108
 Model (RT875CCS) 2-187-110068
 Type Double box beam and jack
 Extended Length 288 in. (731.52 cm)
 Retracted Length 133 in. (337.82 cm)

Hydraulic Swivel

Manufacturer..... Grove
 Model 6-364-001438
 Ports 11 with dual ports on #1

Air/Transmission Swivel

Manufacturer..... Grove
 Model 6-364-001600
 Air Ports 5
 Oil Ports 7

Electrical System

Type Single wire ground return (chassis)
 System Voltage 24
 Starting Voltage 24

Batteries

Number 4
 Rating 610 CCA @ 0°F
 Alternator 65 amp, 24 volt

Emergency Steer Pump

Manufacturer..... John S. Barnes
Model 1380004
Type Gear
Capacity 5.3 gpm (20.1 lpm)
RPM..... 2400
Voltage..... 24 volts

Cab Heater (RT875CCS)

Manufacturer Hunter
Model DH22-22A
Type Internal Combustion
Voltage..... 24 volts (15 amp to start/3.5 amp to run)
Fuel (Consumption) DF-2 (6-1/2 hrs/gal.)
Ignition Solid State (6000 V)
Rating (Output) 15,000 BTU/hr

Cab Heater (RT875CC)

Manufacturer..... Webasto
Model 468-657
Type Internal Combustion
Voltage..... 24 volts
Fuel Diesel
Heat Output 15,000 Btu/hr

Bottom Lift Sling, 20 Ft / 40 Ft Self Leveling

Manufacturer..... Tandemloc, Inc.
Model Q2500AA-400
Weight 1,563 lbs (709 kg)
Lift Capacity (Containers and Contents)..... 67,200 pounds (30.48 MT)
Dimensions:
Length..... 8.35 feet (2.55 m)
Width..... 16 inches (40.6 cm)
Height 3.7 feet (112.8 cm)

Emergency Stowage System (RT875CCS)

Manufacturer Manitowoc Crane Group (Grove)
Part Number (Installation)..... 2-187-810070

Section III - TECHNICAL PRINCIPLES OF OPERATION

INTRODUCTION

This section contains functional descriptions of the operation of the crane's major subsystems. Emphasis is on how the operator's controls interface with the rest of the equipment.

HYDRAULIC SYSTEM

The hydraulic system provides adequate pressure and volume for simultaneous operation of various crane functions. It consists of two pumps, a reservoir, an oil cooler and control valves.

The 165-gallon (624 liter) hydraulic reservoir is located on the right side of the frame. A full flow return type 25- micron filter and a sight gauge are installed in the reservoir.

Pumps. The crane utilizes one three-section pump and one two-section pump. Two pump drive assemblies transmit power from the torque converter to the hydraulic pumps. The three-section pump can be disengaged from the engine for cold weather starting. This is accomplished by a PUMP DISCONNECT lever located on the pump. Pump engagement must be performed with the engine shut down.

Directional Control Valves. The directional control valves are four-way, three-position with either an open or closed spool. The valves are grouped into valve banks permitting simultaneous, independent control of crane functions. The closed spool type valve contains an integral load check valve to prevent back sliding of components which support heavy loads. Each bank contains a main relief valve. Certain crane functions are additionally protected by a circuit relief valve.

Outriggers. The outriggers, part of the carrier frame, are controlled and operated from the cab. They are full hydraulic, double box type. When positioned they provide a rigid four-point platform (fully extended and set) capable of supporting the machine and its maximum load capacity. Integral holding valves and floats are provided. A sight level bubble indicator is

located in the vicinity of the outrigger control panel to assist the operator in leveling the crane.

Turntable Assembly and Swing Mechanism. An anti-friction roller bearing supports the superstructure on the carrier frame, allowing 360 degrees of continuous rotation (swing) in either direction. Swing is accomplished by a hydraulically-driven motor driving a gearbox which in turn drives the roller bearing. A hydraulically actuated brake is used to stop swing and hold the superstructure in the desired position. To further secure the superstructure in a desired position, a positive swing lock is also provided.

Boom Assembly. The boom assembly is a two-section, trapezoidal design and extends from 34.4 to 60.4 feet (10.52 to 18.46 meters). The boom is elevated by two hydraulic cylinders with integral holding valves. Boom elevation is from -4 degrees to +80 degrees.

Main Hoist. The main hoist provides power for all load raising and lowering operations. Two hydraulic motors drive the hoist drum by means of a planetary gear reduction system. A metallic disc brake is also an integral part of the hoist assembly, and operates automatically when the control lever is in neutral.

Auxiliary Hoist. The auxiliary hoist provides power for all load raising and lowering operations when the auxiliary boom nose is installed. Two hydraulic motors drive the hoist drum by means of a planetary gear reduction system. A disc brake is also an integral part of the hoist assembly. It operates automatically when the control lever is in neutral position.

Control Lever Lockout System. The control lever lockout will automatically deactivate various control directions or functions which would tend to hasten an impending overload condition of the crane or two-block direction or condition. The system consists of a solenoid controlled air cylinder, and the associated linkage and rods to lockout functions that may worsen the condition, i.e., boom down,

telescope out or hoist up; therefore, when control lever lockout occurs, the control levers can only be moved in a direction that will alleviate the condition. Lockout occurs when the solenoid is deenergized, closing an exhaust port and allowing air pressure to be supplied to the cylinder piston. Lockout is removed when the solenoid is energized, exhausting the air and allowing spring pressure to retract the cylinder piston.

Swing/Boom Warning System. The swing/boom warning system provides a visual and audible warning to the operator that the boom is not elevated sufficiently to clear the engine hood when swinging the boom over the rear. The red warning light is located in the LED alert display. The light and buzzer are controlled by two micro-switches electrically connected in series. One switch senses boom elevation and the other switch senses boom position in relation to swing. If boom elevation is below 7.5 degrees and swing is initiated, the warning indicator will illuminate and an alarm will sound when swing exceeds 90 degrees in either direction from directly over the front.

STEERING SYSTEM

The steering system uses hydraulically controlled steering cylinders mounted to the axles. For maximum maneuverability, the front and rear axles are drive and steer (axles). Two-wheel drive or four-wheel drive can be selected. The front axle has full power steering. The rear axle utilizes full hydraulic control and is operated independently of the front steer via a control lever adjacent to the steering wheel.

An electric motor driven, hydraulic pump provides emergency steering hydraulic pressure.

AIR SYSTEM

The engine compressor provides the air supply to operate the air service brakes, parking brakes, engine throttle, and transmission range shift and rear axle disconnect. Air flow is transmitted from the carrier frame to the superstructure through a swivel located at the center of rotation.

ELECTRICAL SYSTEM

The electrical system is a 24-volt operation and starting system, consisting of an alternator and four lead-acid batteries, which are series-parallel connected. The system is single wire-ground return type utilizing the machine's structure as ground. The system features a battery disconnect switch that will de-energize the crane's electrical system (RT875CCS).

PAT/LMI SYSTEM

WARNING

The LMI is an operational aid only.

The device is not, and shall not be, a substitute for good operator judgement, experience and use of accepted safe crane operating procedures.

The responsibility for the safe operation of the crane shall remain with the crane operator who shall ensure that all warnings and instructions supplied are fully understood and observed.

Prior to operating the crane, the operator must carefully and thoroughly read and understand the information in this manual to ensure that he knows the operation and limitations of the indicator and crane.

The PAT/LMI (Load Moment Indicator) System is an electro-mechanical sensing and alarm system that provides vital lift data to the operator. The system senses current boom length, boom angle, and working radius as well as load weight. This data is displayed on a control panel mounted above the instrument panel in the cab. When an impending overload condition is sensed, the system provides the operator with visual and audible warnings. It locks out the control levers to prevent lowering the boom, extending the boom or raising the main/auxiliary hoist cables. Anti-two block devices prevent the hook block from coming into contact with the boom nose. This condition will also cause a lockout of the above mentioned functions.

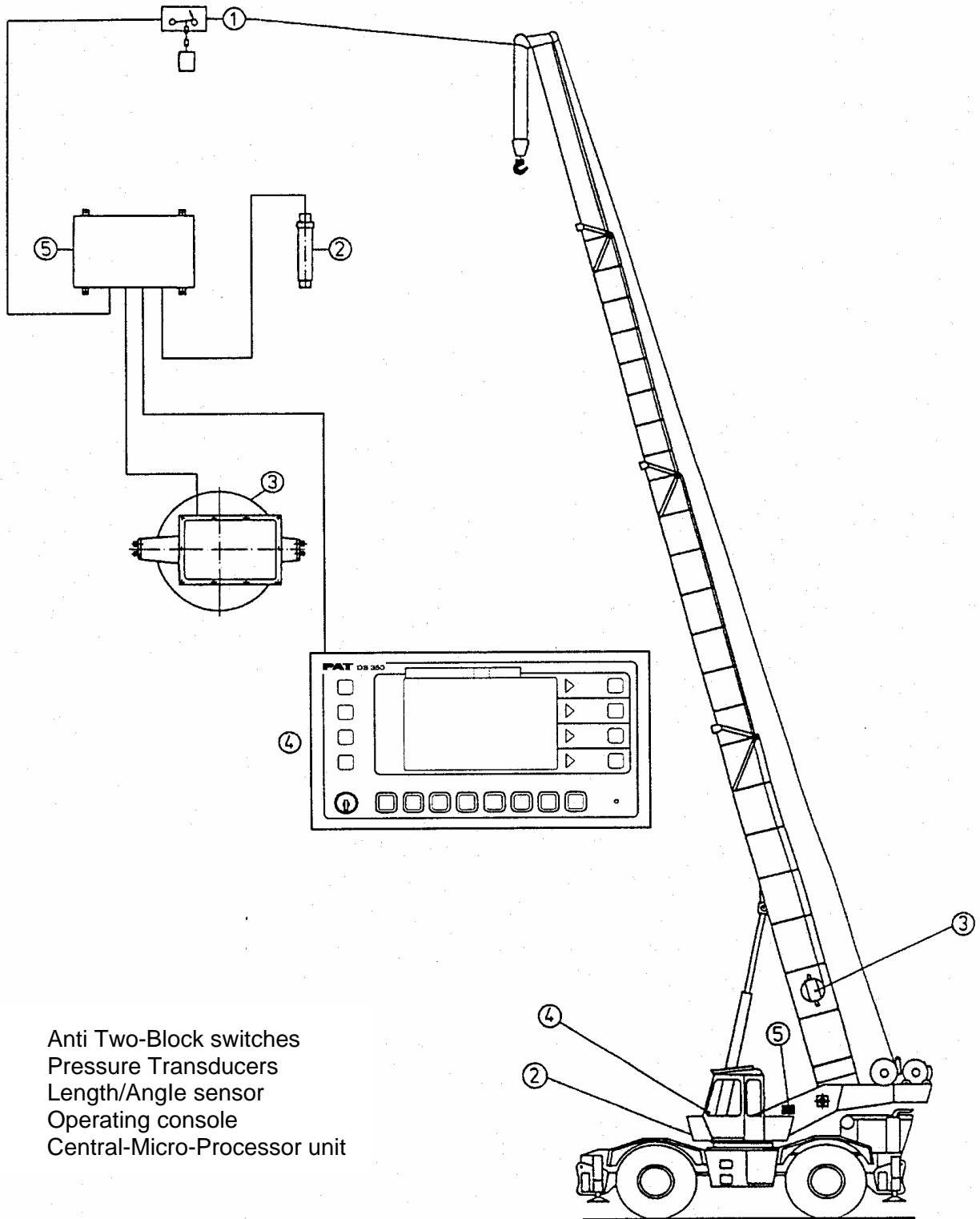

- 1 Anti Two-Block switches
- 2 Pressure Transducers
- 3 Length/Angle sensor
- 4 Operating console
- 5 Central-Micro-Processor unit

PAT LMI SYSTEM

CHAPTER 2 – OPERATING INSTRUCTIONS

Section I - Description and Use of Operator's Controls and Indicators

PURPOSE

This section shows the operator controls and

indicators, including the associated panel markings. It provides functional descriptions from the operator's point of view.

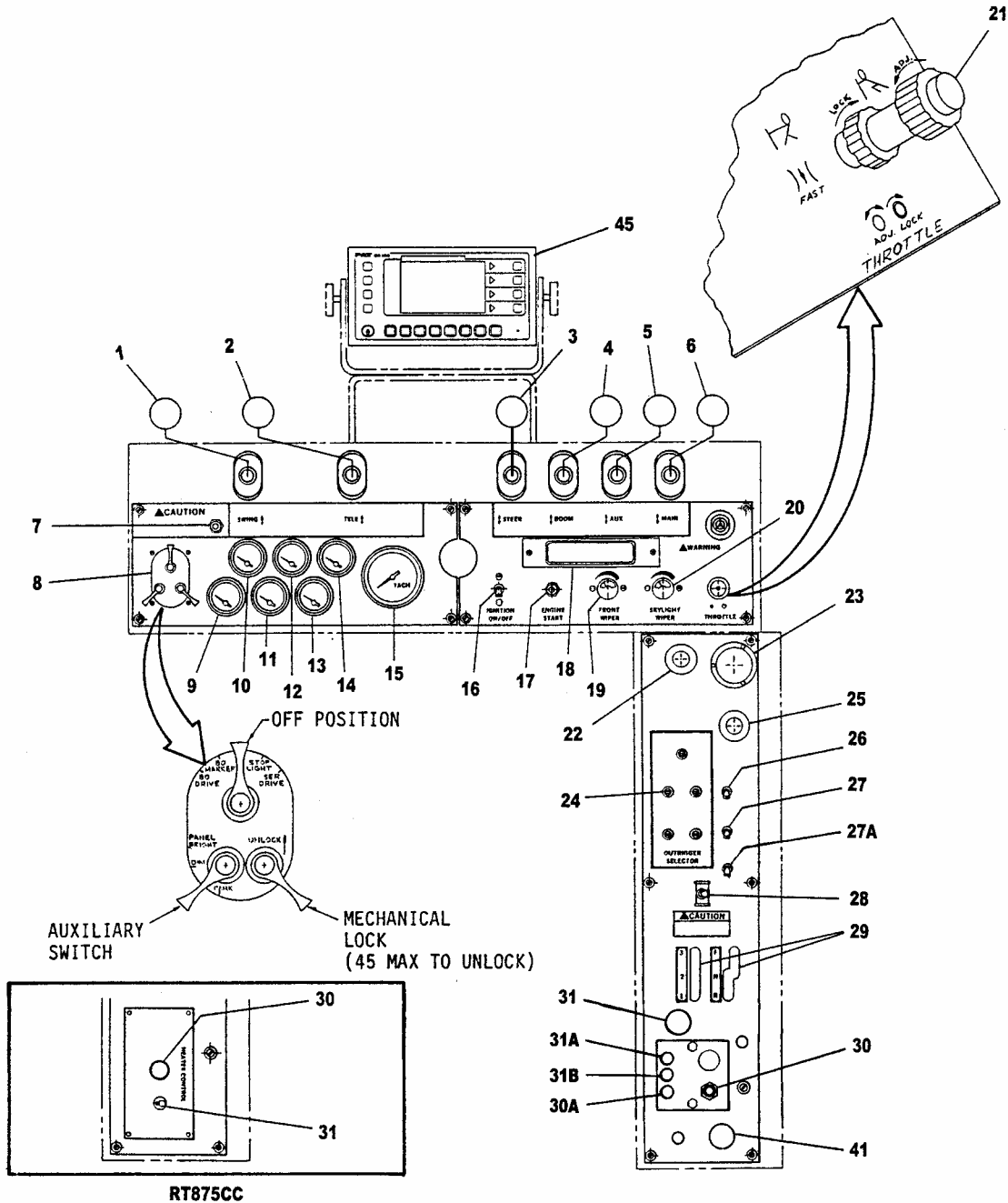

Cab Controls and Indicators

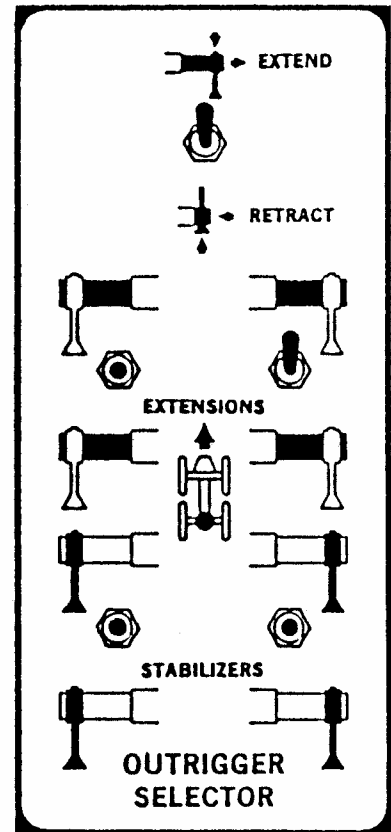
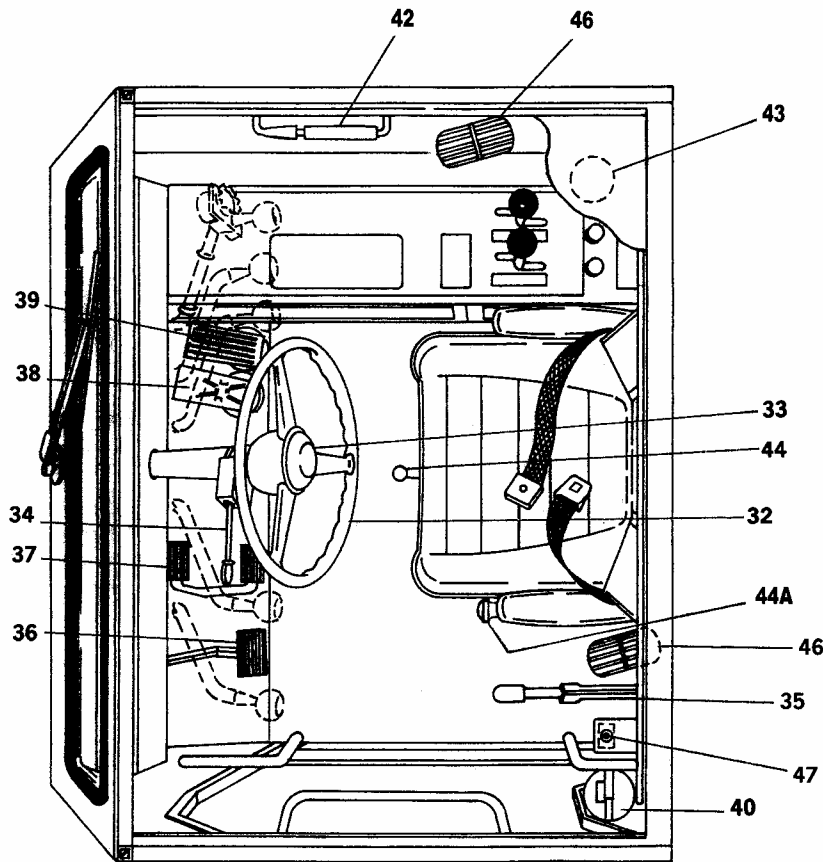

OUTRIGGER SELECTOR PANEL

Table 2-1. Control Panel Controls and Indicators

Key	Control or Indicator	Function
1	SWING Control Lever	Push lever forward to rotate boom superstructure clockwise (right). Pull lever to rotate boom superstructure counterclockwise (left).
2	TELE Control Lever	Push lever forward telescope (extend) boom. Pull lever to retract boom.
3	STEER Control Lever	Push lever forward to steer rear of crane to left. Pull lever to steer rear of crane to right.

Table 2-1. Control Panel Controls and Indicators – Continued

Key	Control or Indicator	Function
4	BOOM Control Lever	Pull lever back to increase boom elevation angle. Push lever to lower boom elevation.
5	AUX Control Lever	Push lever forward to lower auxiliary hoist cable. Pull lever to raise auxiliary hoist cable.
6	MAIN Control Lever	Push lever forward to lower main hoist cable and hook block. Pull lever to raise main hoist cable and hook block.
7	Quick Start Push-button	Depress pushbutton while IGNITION switch is ON and ENGINE START is depressed to inject ether start fluid into engine air intake.
8	Blackout Lights Switch	BO DRIVE/BO MARKER/OFF/STOP LIGHT/SER DRIVE selects Which outside lights are controlled. PANEL BRIGHT/DIM/OFF/PARK selects condition of control panel lights. UNLOCK selects blackout or normal mode.
9	OIL PRESS Gauge	Indicates engine lube oil Pressure, 0 to 100 psi (0 to 690 kPa).
10	AIR PRESSURE Gauge	Indicates air pressure in primary air system (green pointer) and secondary air system (red pointer). Scale reads 0 to 150 psi (100 to 1000 kPa).
11	WATER TEMP Coolant Temperature Gauge	Indicates engine coolant temperature, 100 to 280°F (38 to 130°C).
12	OIL TEMP Transmission Temperature Gauge	Indicates transmission oil temperature, 140 to 320°F (60 to 160°C).
13	Fuel Gauge	Indicates fuel level in fuel tank 0 to full 4/4.
14	BATTERY DC Voltmeter	Indicates voltage to or from battery. In volts (DC) from 20 to 32.
15	TACH/HOURS Tachometer/Hourmeter	Indicates engine speed in RPMs 0 to 40 (times 100). Indicates total diesel engine operating hours (including tenths).

Table 2-1. Control Panel Controls and Indicators – Continued

Key	Control or Indicator	Function
16	IGNITION ON/OFF Switch	ON - Energizes 24 VDC circuit enabling diesel engine start circuit. OFF - Shuts down diesel engine.
17	ENGINE START Pushbutton	Depress to energize diesel engine starting circuit. Engages starting motor solenoid while pushbutton is depressed.
18	LED ALERT Display	Provides visual and audible indication of crane malfunctions and conditions.
19	FRONT WIPER Switch	Turn switch clockwise to first stop for slow wiper speed. Turn switch clockwise to second stop for fast wiper speed. Turn switch counterclockwise to stop wipers.
20	SKYLIGHT WIPER Switch	Turn switch clockwise to first stop for slow wiper speed. Turn switch clockwise to second stop for fast wiper speed. Turn switch counterclockwise to stop wipers.
21	THROTTLE Control knob	Push button and pull knob to set engine speed. Depress button and push knob to Release throttle. Rotate collar to lock engine speed at desired level.
22	Park Brake Knob	Push knob to release park brake. Pull knob to set park brake.
23	Bubble Level	Indicates crane levelness.
24	OUTRIGGER SELECTOR Control Panel – Toggle Switches	EXTEND - extends selected outrigger cylinder. RETRACT - Retracts selected outrigger cylinder.
25	SWING BRAKE Control Knob	Push to set swing brake and prevent crane superstructure rotation.
26	REAR HEAD LAMPS Switch	ON - Lights rear floodlights mounted on crane frame. OFF - Turns off rear floodlights mounted on crane frame.

Table 2-1. Control Panel Controls and Indicators – Continued

Key	Control or Indicator	Function
27	FLOOD LAMP (RT875CC) BOOM LIGHTS (RT875CCS) Switch	ON - Lights boom mounted floodlights. OFF - Turns off boom mounted floodlights.
27A	WORK LIGHT Switch (RT875CCS)	ON - Lights cab mounted area work light. OFF – Turns off cab mounted area work light.
28	DRIVE AXLE Switch	2WD HI - Selects two-wheel drive mode. Front wheels are driven. 4WD LO – Selects four-wheel drive mode. All wheels are driven.
29	1-2-3/FNR Transmission Control Lever	1 - Selects low gear in transmission. 2 - Selects second gear in transmission. 3 - Selects high gear in transmission. F - Selects forward travel direction for crane. N - Selects neutral. No wheels are driven. R - Selects rear direction for crane travel.
30	HEATER Control Switch (RT875CC)	PULL – Turns cab heater on. PUSH – Shuts cab heater off.
30	Heater START/OFF Switch (RT875CCS)	START – Turns on cab heater fuel pump, ignites fuel in heat exchanger, and turns on heater fan. OFF – Shuts down cab heater. Heater fan will continue to run until heat exchanger has cooled down.
30A	PUSH TO RESET Button (RT875CCS)	Depressed – Resets cab heater relay after fault in preparation for restarting cab heater via START/OFF switch (30).
31	AIR TEMP Switch (RT875CC)	HI – Turns cab heater circulating fan on high speed. LO – Turns cab heater circulating fan on slow (low) speed.
31	HEATER LO-HI Push/Pull Knob (RT875CCS)	Pull – Increases cab heater temperature output. Push – Decreases cab heater temperature output.
31A	PWR ON Green Indicator (RT875CCS)	Lights when cab heater is running and functioning normally.
31B	FAULT Red Indicator (RT875CCS)	Lights to indicate a cab heater malfunction.

Table 2-1. Control Panel Controls and Indicators – Continued

Key	Control or Indicator	Function
32	Steering Wheel	Turn clockwise to steer front wheels to right. Turn counterclockwise to steer left.
33	Horn Pushbutton	Depress to sound horn.
34	Turn Signal/Four-Way Flashers Control Lever and Switch	Pull lever up to light right-side turn signals. Push lever down to light left-side turn signals. Pull down small switch behind lever to light four way flashers.
35	Swing Lock Control Lever	Push lever to engage mechanical swing lock to prevent boom superstructure rotation. Pull lever to release mechanical swing lock.
36	Swing Brake Pedal	Depress pedal to apply swing brake and slow/stop crane superstructure rotation.
37	Boom Lift Control Pedal	Depress toe of pedal to lower boom. Depress heel of pedal to raise boom.
38	Service Brake Foot Pedal	Depress brake pedal to engage service brakes at all four wheels.
39	Throttle Pedal	Depress pedal to increase fuel flow through diesel engine governor increasing diesel engine speed.
40	Fire Extinguisher	Pull ring and depress lever to operate fire extinguisher. Charge gauge indicates green (for charged) and red (for service required).
41	Front Windshield Washer	Push to operate front windshield washer spray.
42	Skylight Window Counterbalance Cylinder Adjustment	Turn knob counterclockwise to loosen cylinder brake. Position skylight as desired. Turn knob clockwise to tighten cylinder brake and hold skylight in desired position.
43	Domelight	Provides light for cab. ON/OFF switch located on light.
44	Operator Seat Adjustment	Push lever to side to unlock seat and slide seat forward or back. Release lever to lock seat.

Table 2-1. Control Panel Controls and Indicators – Continued

Key	Control or Indicator	Function
44A	PULL FOR AIR FLOW Knob (RT875CCS)	Pulled out - Opens flapper valve to allow air flow from cab heater to the front windshield defroster duct. Pushed in – Closes flapper valve to shutoff air flow to the front windshield.
45	Load Moment Indicator	Refer to Table 2-2.
46	Cab Fans	Provides air circulation within cab. ON/OFF switch with speed control located on fan base.
47	Beacon Light Switch	ON – Lights beacon light on top of cab. OFF – Turns off beacon light on top of cab.
48	Boom Angle Indicator (Not Shown)	Provides mechanical indication of boom angle. Indicator is mounted on left-rear side of boom.

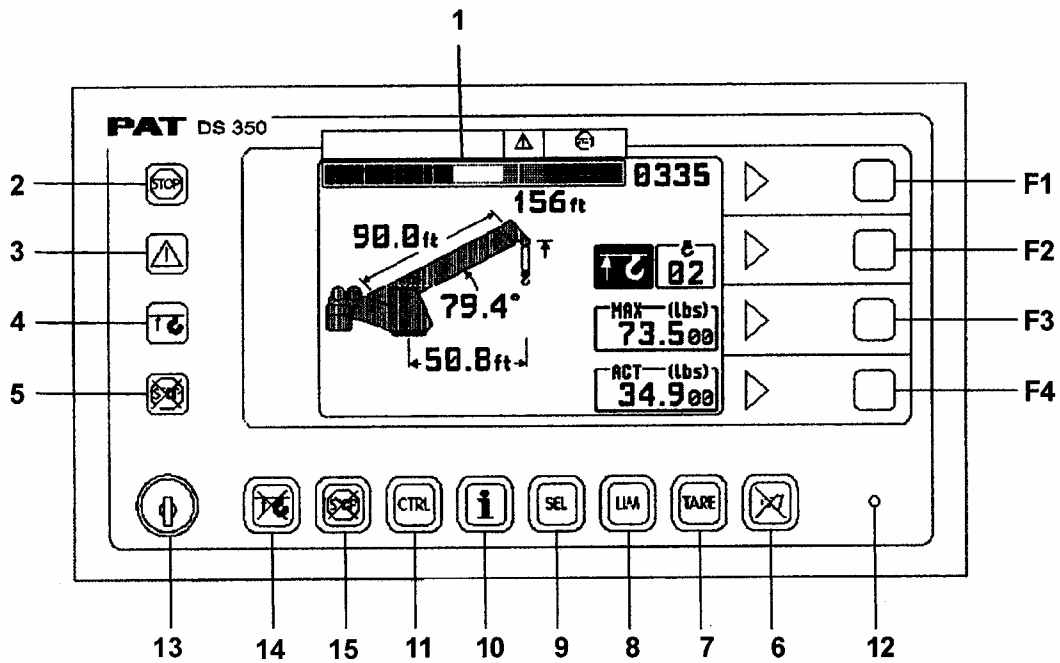

Table 2-2. Load Moment Indicator (RT875CCS)

Key	Control or Indicator	Function
1	Liquid Crystal (LC) Display Area	Displays graphical symbols, texts, and numerical values. Depending on the selected operating mode (setup, limit mode or LMI representation), the corresponding information is indicated on the display.
2	Load Moment Limit Light - STOP	Lights (Red) to warn the operator that a rated load condition has been reached. It lights up when the load on the crane reaches the crane load capacity. The audible alarm also sounds when this condition has been reached. The following crane movements will be stopped concurrently: <ul style="list-style-type: none"> • hoist up • telescope out • boom down

Table 2-2. Load Moment Indicator (RT875CCS) – Continued

Key	Control or Indicator	Function
3	Load Moment Prewarning Light	Lights up (Yellow) when the load on the crane reaches the defined prewarning area, thus indicating that an overload condition is approaching. This means for the operator to continue his crane operation with extreme caution.
4	Alarm Light – “Anti-Two Block”	<p>Lights (Red) when the anti-two block limit switch contacts open, indicating that a two blocking condition is approaching. At the same time the audible alarm will sound.</p> <p>The following crane movements will be stopped subsequently:</p> <ul style="list-style-type: none"> • hoist up • telescope out • boom down
5	Override Key Warning Light	Light flashes on and off when cut-off function of the A2B/LMI system is deactivated.
6	Button “Alarm Stop”	Depressed - Allows the audible alarm to be silenced for approximately 15 seconds.
7	Button and Control Light TARE	<p>Depressed – LC Display (1) indicates “Net load”. Net load is the present load, less lifting tackle and hook block. The TARE Button (7) has to be depressed with the lifting tackle suspended from the hook and <u>before</u> lifting the actual load.</p> <p>After pushing the TARE Button (7) the load display is set to zero (taring) and the control light lights up. After lifting a load the display shows the net load (pay load).</p> <p>The net load display will change to the actual load display when the boom radius is changed (either by angle or length).</p>

NOTE

The LMI system automatically deducts the weight of the hook block. However, the TARE function cannot be used to calculate net load if the lifting tackle (minus the hook block) weighs less than 3,000 pounds (1,364 kg). For example, the TandemLok bottom lift sling used for container lifts weighs less than 3,000 pounds. Therefore, the LMI system cannot be used to display net container weight using the TARE function.

Table 2-2. Load Moment Indicator (RT875CCS) – Continued

Key	Control or Indicator	Function
8	Button and Control Light LIM (Limits)	Depressed – Starts the function “program limit values”. Refer to page 2-48.
9	Button and Control Light SEL (Select Operation Mode)	<p style="text-align: center;">WARNING</p> <p>Setting the operational mode is critical for the proper function of the system and the crane. Therefore only operators who are thoroughly familiar with use and operation of the system shall set this button.</p> <p>Depressed – Starts the function “select operation mode”. Refer to page 2-47.</p>
10	Button and Control Light I (Information)	Depressed – Starts the function “crane information configuration”. Refer to page 2-49
11	Button and Control Light CTRL (Control)	Depressed – Starts additional functions. Refer to page 2-49.
12	Audible Alarm	<p>Sounds during the following conditions:</p> <ul style="list-style-type: none"> • overload condition • approaching two-block condition • preset limits reached • malfunction of the LMI system • operating error <p>The alarm can be temporarily silenced by pushing the button “Alarm Stop” (6).</p>
13	By-Pass Key Switch	<p>When turned to position “B” while “By-Pass A2B” button (14) is depressed - The anti-two block switch cut-off function is deactivated.</p> <p>OR</p> <p>When turned to position “B” while “By-Pass LMI” button (15) is depressed - The LMI cut-off function is deactivated.</p>

Table 2-2. Load Moment Indicator (RT875CCS) – Continued

Key	Control or Indicator	Function
WARNING		
<p>Since buttons (14) and (15) deactivate the cut-off function of the LMI system/ anti-two block system, the following instructions must be obeyed:</p>		
<ol style="list-style-type: none"> 1. The by-pass function shall be used only with command authorization, as unwarranted use of it to override the LMI control lever lockout system can result in harm to the crane and danger to property and personnel. 2. Never use the by-pass function to either overload or operate the crane in an unsafe condition. 		
14	Button and Control Light “By-Pass A2B”	<p>Operates when key switch (13) is turned to position B. After depressing this button, the cut-off function of the anti-two block switch is deactivated.</p> <p>The Override Key Warning Light (5) flashes to indicate that the cut-off function is deactivated.</p>
15	Button and Control Light “By-Pass LMI” shut-off function	<p>Operates when key switch (13) is turned to position B. After depressing this button, control lever lockout function is deactivated.</p> <p>The Override Key Warning Light (5) flashes to indicate that the cut-off function is deactivated.</p>
F1	Button F1	Use as needed for LMI setup. Refer to LMI programming, page 2-46.
F2	Button F2	Use as needed for LMI setup. Refer to LMI programming, page 2-46.
F3	Button F3	Use as needed for LMI setup. Refer to LMI programming, page 2-46.
F4	Button F4	Use as needed for LMI setup. Refer to LMI programming, page 2-46.

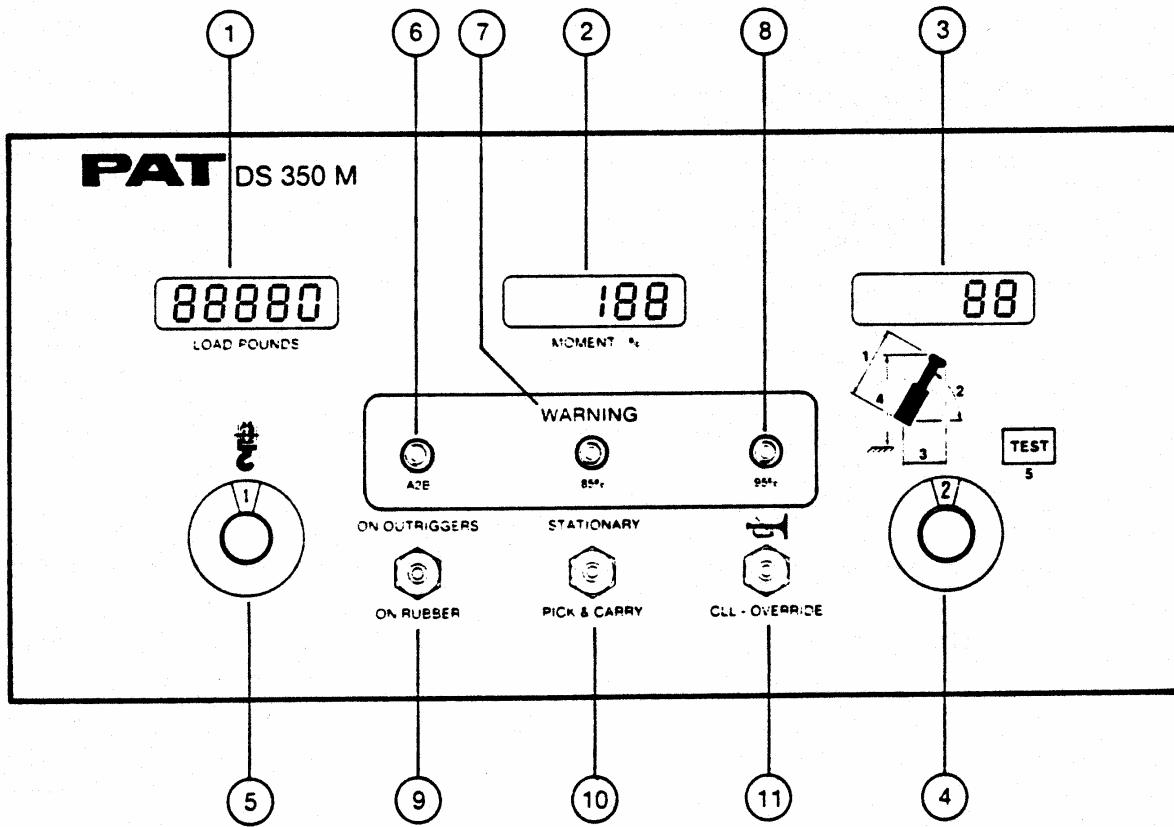

Load Moment Indicator (RT875CC)

Table 2-2. Load Moment Indicator (RT875CC)

Key	Control or Indicator	Function
1	Load/Pounds Digital Display	Indicates actual load (gross load) in pounds being picked up by the crane. Indication includes loads on both hoists (main/auxiliary) and all lifting equipment (slings, hook block, overhaul ball, etc.). When load on hook is less than 9,000 lbs., error code E80 will appear. Refer to TROUBLESHOOTING PROCEDURES, page 3-2, for an explanation of error code.

Table 2-2. Load Moment Indicator (RT875CC) - Continued

Key	Control or Indicator	Function
2	MOMENT/PERCENT Digital Display	<p>Indicates percent of total Digital display crane lifting capacity being used at any given moment in the craning cycle.</p> <p>In the case of a malfunction of the Load Moment Indicator System or an operating error, the display will indicate an error code used to identify system problems. Refer to TROUBLESHOOTING PROCEDURES, page 3-2, for an explanation of error codes.</p>
3	Data Digital Display	Displays cranes operating data as selected by Data Selector Switch.
4	Data Selector Switch	<p>Determines which crane operating data is displayed by the digital display by positions.</p> <ul style="list-style-type: none"> 1 - Selects boom length for display (in feet). 2 - Selects boom angle for display (in degrees). 3 - Selects operating radius for display (in feet). 4 - Selects boom tip height above ground for display (in feet). 5 - Test. Lights all lamps and sounds horn. MOMENT display (2) and data display (3) show "-188.8" and LOAD display shows "88880". Dangerous crane movement being performed during test will stop.

WARNING

Selecting the correct number of line parts is critical to the operation of the load moment indicator. Selecting the wrong number will result in faulty indications and possible personnel injury or equipment damage.

5	Reeving Selector Switch	Select number 1 thru 6 to correspond to number of parts of line being used. The container crane with the standard hook block is a six (6) part configuration. With the overhaul ball, the line is one (1) part.
6	A2B Red Indicator Light	Lights when anti-two block (A2B) switch is tripped causing the system to lockout craning operations.

Table 2-2. Load Moment Indicator (RT875CC) - Continued

Key	Control or Indicator	Function
7	85% Yellow Indicator Light	Lights when crane is lifting 85% of its rated capacity. Warning does not lock out operations.
8	95% Red Indicator Light	Lights when crane is lifting 95% of its rated capacity. An audible alarm will also sound. Warning does not lock out craning operations.

WARNING

Ensure that when performing craning operations on rubber (i.e. without extending the outriggers) the ON OUTRIGGERS/ON RUBBER selector switch is set to ON RUBBER. Otherwise the load moment indicator will show craning values that are not accurate. Failure to follow this procedure could result in personnel injury and/or equipment damage.

NOTE

At 100% of rated capacity, hoist up, boom down and telescope out functions will be locked out.

9	ON OUTRIGGERS/ON RUBBER	<p>ON OUTRIGGERS -Select this Selector switch position when operating crane on outriggers (i.e. outriggers lowered and extended).</p> <p>ON RUBBER - Select this position when operating crane on rubber (i.e. with outrigger up and retracted).</p>
---	-------------------------	--

WARNING

Ensure that when performing pick and carry operations (i.e. moving the crane while lifting a load) the STATIONARY/PICK & CARRY switch is set at PICK & CARRY. Otherwise, the load moment indicator will show craning values that are not accurate. Failure to follow these procedures could result in personnel injury and/or equipment damage.

10	STATIONARY/PICK & CARRY Selector switch	<p>STATIONARY - Select this position when performing craning operations with the crane standing still.</p> <p>PICK & CARRY - Select this position when performing craning operations with the crane moving.</p>
----	---	---

Table 2-2. Load Moment Indicator (RT875CC) - Continued

Key	Control or Indicator	Function
-----	----------------------	----------

WARNING

Before using the CLL-OVERRIDE be aware that you are disabling a safety device: The automatic control lever lockout system. Do not assume that safety devices installed on this crane have failed when craning operations "appear" to be within crane operating capacities when the alarm occurs - Investigate first! Failure to observe this warning could result in personnel injury and/or equipment damage.

11	CLL – OVERRIDE Momentary Selection switch	<p>UP - When alarm is on, overrides audible alarm for 15 seconds.</p> <p>CLL- OVERRIDE - Depress and Hold to override the load moment indicator and anti-two block. Enables the operator to override the automatic control lever lockout system. Release switch to reactivate the protective system.</p>
----	---	--

SECTION II – PREVENTIVE MAINTENANCE CHECKS AND SERVICES

GENERAL

1. Before you operate. Always keep in mind the CAUTIONS and WARNINGS. Perform your before (B) PMCS.
2. While you operate. Always keep in mind the CAUTIONS and WARNINGS. Perform your during (D) PMCS.
3. After you operate. Be sure to perform your after (A) PMCS.
4. If your equipment fails to operate. Troubleshoot with proper equipment. Report any deficiencies using the proper forms. See TM 38-750.

Procedure

PMCS procedures in the table are intended to insure that the crane is ready to be operated safely and with minimum crane wear and tear.

The PMCS table lists the checks and services that need to be performed at various intervals. The intervals were determined by crane design and expected use.

1. "Before" or (B) PMCS shall be performed by the operator prior to starting the mission.
2. "During" or (D) PMCS shall be performed while operating the crane both while sitting in the cab manipulating the controls and when outside the cab doing other tasks associated with operations.
3. "After" or (A) PMCS shall be performed after crane operation and when it is being shut down for a period of time.
4. "Weekly" or (W) PMCS need not be done every day or every time the crane is operated, but must be done relatively frequently, and not delayed or forgotten. A weekly routine must be established to check and service these items.
5. "Monthly" or (M) PMCS provides checks and services that need not be done weekly but cannot be ignored more than a month. A monthly service routine must be

established.

6. There are checks and services that must be done on the basis of the number of hours of engine operation, or based on special environmental conditions. These more frequent checks are marked with an asterisk.

An appropriate footnote explains the special service interval.

Additional Special Checks and Services

Perform weekly (W) as well as before (B) operations PMCS if:

1. You are the assigned operator and have not operated the crane since the last weekly.
2. You are operating the crane for the first time. Leakage definitions for operator/crew PMCS shall be classified as follows:

- | | |
|-----------|--|
| Class I | Seepage of fluid (as indicated by wetness or discoloration) not great enough to form drops. |
| Class II | Leakage of fluid great enough to form drops but not enough to cause drops to drip from item being checked/inspected. |
| Class III | Leakage of fluid great enough to form drops that fall from the item being checked/inspected. |

CAUTION

Equipment operation is allowable with minor leakages (Class I or II). Of course, you must consider the fluid capacity in the item/system being checked/inspected. When in doubt, notify your supervisor.

When operating with Class I or Class II leaks, continue to check fluid levels as required in your PMCS.

Class III leaks should be reported to your supervisor or organizational maintenance.

Equipment is Not Ready/Available If: Column provides clear description of the conditions in which the crane shall not ever unequivocally be operated, due to personnel safety and/or prospect of equipment damage.

Deficiencies in the crane and its performance shall be reported to your supervisor, and/or to

your organizational maintenance group on Form 2408-X as well as noted in the Equipment Daily Log, Form 2408-1.

PMCS can be performed by the operator without removing any assemblies.

OPERATOR PREVENTIVE MAINTENANCE CHECKS AND SERVICES (PMCS)

NOTE

Within designated interval, these checks are to be performed in the order listed.

B – Before

A – After

M – Monthly

D – During

W - Weekly

ITEM NO	INTERVAL					ITEM TO BE INSPECTED PROCEDURE: CHECK FOR AND HAVE REPAIRED, FILLED, OR ADJUSTED...	EQUIPMENT IS NOT READY/AVAILABLE IF:
	B	D	A	W	M		
						<p align="center">GENERAL</p> <p>Assure that all daily/weekly lubrication requirements are performed on the crane as directed by the Lubrication Order.</p> <p>Ensure that BATTERY DISCONNECT switch in off position before beginning the inspection for overall condition.</p> <p align="center"><u>CAUTION</u></p> <p>When checking all liquid levels, the crane should be level to obtain proper readings.</p> <p>Levers, pins, linkage, etc., not equipped with lubrication fittings should operate freely and be free of corrosion. Lubricate with oil, SAE 30.</p> <p>Perform weekly (W) as well as before (B) Operator’s PMCS if:</p> <ol style="list-style-type: none"> 1. You are the assigned operator and have not operated the crane since the last weekly check. 2. You are operating the crane for the first time. 	
1	•					<p align="center"><u>CRANE EXTERIOR</u></p> <p><u>OVERALL GENERAL CONDITION</u> When performing other PMCS checks:</p> <ol style="list-style-type: none"> a. Check for flaking/cracking paint or rust which may indicate dangerous cracks in the carrier frame or superstructure. b. Check for loose or missing attaching hardware. c. Check all placards and decals for security and legibility. 	<p>Any cracks in carrier frame, boom, or turntable.</p> <p>Loose or missing attaching hardware.</p> <p>Damaged/missing warning/safety decals and placards.</p>

Operator PMCS – Continued

ITEM NO	INTERVAL					ITEM TO BE INSPECTED PROCEDURE: CHECK FOR AND HAVE REPAIRED, FILLED, OR ADJUSTED...	EQUIPMENT IS NOT READY/AVAILABLE IF:
	B	D	A	W	M		
2	●					<p><u>CARRIER</u></p> <p>a. Inspect underside of carrier and components (e.g., frame, axles, steering linkage, engine, transmission case, fuel and oil lines, etc.) for damage and evidence of leaks. Check axle differentials for cracks and leaks. Check brake lines for security, chafing, and leaks.</p> <p>b. Inspect all air system components for damage, security, and leaks. Check for broken mounting structures including worn, loose, or missing attaching hardware.</p> <p>c. Air System Reservoirs. Open two secondary air reservoir drain valves slightly to drain water. Push automatic drain valve on primary air reservoir to drain water.</p> <p>d. Inspect torque converter oil filter element for leaks and tightness.</p> <p>e. Tool Box (RT875CC). Ensure that three (3) emergency load lowering hoses and pump handle are stowed in the tool box. Ensure that drain pan is stowed.</p>	Damaged frame or component(s), any fuel leak or Class III oil leak.
3	●					<p><u>BOOM, CYLINDERS, AND VALVES</u></p> <p>a. Inspect all hydraulic cylinders and valves for damage, security, and leaks as you proceed around the crane.</p> <p>b. Check for cracked or broken mounting structures including worn, loose, or missing pivot pins and attaching hardware.</p> <p>c. Inspect boom and boom nose sheaves for excessive dirt, grease, and debris.</p>	Cracked or broken components, loose or missing hardware, or Class III leak.
4	●					<p><u>HYDRAULIC RESERVOIR AND FILTER</u></p> <p style="text-align: center;"><u>CAUTION</u></p> <p>Ensure all hydraulic cylinders are fully retracted when checking hydraulic fluid level.</p> <p>a. Check sight gauge (on front of hydraulic tank) for proper oil level. Ensure that oil is visible between HIGH and LOW marks on sight gauge.</p> <p>b. Inspect hydraulic tank breather intake element/filter for cleanliness</p>	<p>a. Hydraulic oil level low; Class III leak exists</p> <p>Hydraulic tank breather is plugged with debris or breather missing.</p>

Operator PMCS - Continued

ITEM NO	INTERVAL					ITEM TO BE INSPECTED PROCEDURE: CHECK FOR AND HAVE REPAIRED, FILLED, OR ADJUSTED...	EQUIPMENT IS NOT READY/AVAILABLE IF:
	B	D	A	W	M		
5	●					<p><u>FUEL TANK AND LINES</u></p> <p>a. Inspect fuel tank and lines for damage, security and evidence of leaks.</p> <p>b. Check for missing fuel filler cap.</p> <p>c. Check fuel tank filler screen for damage and debris.</p>	Any fuel system component damaged, loose, or leaking. Any fuel leaks. Fuel filler cap missing.
6	●					<p><u>FUEL HEATER/WATER SEPARATOR (RT87CCS)</u></p> <p>a. Open drain hose valve on bottom of fuel water separator bowl which is located on the left-rear side of the diesel engine. Get set to catch fuel/water in suitable drip pan.</p> <p>b. Drain water and sediment from fuel water separator by pushing pump button on top of filter head until clean fuel flows out of drain tube into drip pan.</p> <p>c. Close drain hose valve.</p>	Any fuel leak exists.
7	●					<p><u>FUEL FILTER-WATER SEPARATOR AND SEDIMENT BOWL (RT875CC)</u></p> <p style="text-align: center;"><u>CAUTION</u></p> <p>Drain fuel into suitable container. Not directly on to the ground.</p> <p>a. Check for water in the primary fuel filter by opening petcock (right side of engine) to drain water. Do not overtighten petcock.</p> <p>b. Check fuel sediment bowl for dirt and water. Bowl located on left rear inner frame rail.</p>	Any fuel leak exists. Fuel sediment bowl damaged or clogged.
8	●					<p><u>PINTLE HOOK</u></p> <p>a. Inspect pintle hook safety chain and pin for damage.</p> <p>b. Ensure pintle hook operates and rotates freely by hand.</p>	Pintle hook damaged or not functional and/or safety chain/pin damaged or missing for towing operations.
9	●					<p><u>TIRES AND WHEELS</u></p> <p style="text-align: center;"><u>WARNING</u></p> <p>To inflate a tire that is removed from the crane, always use a tire inflation cage and clip on inflator as tire rim parts can fly apart with lethal force.</p> <p>DO NOT MIX BIAS-PLY AND RADIAL-PLY TIRES.</p>	<p style="text-align: center;">NOTE</p> <p>If you are not sure about a tire's serviceability, contact your supervisor/ Organizational Maintenance.</p>

Operator PMCS – Continued

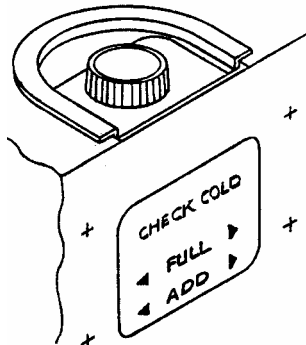
ITEM NO	INTERVAL					ITEM TO BE INSPECTED PROCEDURE: CHECK FOR AND HAVE REPAIRED, FILLED, OR ADJUSTED...	EQUIPMENT IS NOT READY/AVAILABLE IF:
	B	D	A	W	M		
10	●					Inspect tires for: a. Missing valve caps, low air pressure/flat tires, or loose/missing lug nuts. b. Scaling rust or debris along the joint of the tire bead and rim. If noted, contact maintenance to dismount and inspect tire for bead chafing. c. Blisters or bulges in the sidewall. This indicates ply separation. If noted, contact maintenance to dismount and inspect tire. d. Tread separation. This indicates a tire manufacturing defect, and the tire should be replaced. e. Cuts or cracks in the sidewall or tread that expose the cords. Exposed cords indicate the tire should be replaced <u>EXTERIOR LIGHTS</u> a. Check for cracked or broken lenses. b. Inspect connectors/ wiring for security and damaged insulation	Tire air pressure less than 75 psi (517 kPa), flat/damaged tire, excessive wear, or loose/missing lug nut(s). Crane is equipped with mixed tire types: bias-ply tires and radial-ply tires. All four tires must be of the same type. a. Any lens cracked or broken for night operation. b. Loose connectors/wiring or damaged installation for night operation.
11	●					<u>OUTRIGGER FLOATS</u> Check for cracked or broken welds and cracks/damage in the pad structure.	Floats are required for craning operations.
12	●					<u>AIR FILTER RESTRICTION INDICATOR</u> Check air filter restriction indicator for red flag indicating fouled filter.	Red flag appears.
13	●					<u>AIR CLEANERS AND PIPING</u> a. Pinch air cleaner evacuator several times to eliminate accumulated dirt. b. Inspect air filter housing, air intake piping, and all clamps for damage and security.	Damaged or loose air intake components.
14	●					<u>ANTIFREEZE/COOLANT SYSTEM</u> <div style="border: 1px solid black; padding: 2px; display: inline-block; margin: 10px 0;">WARNING</div> The cooling system is pressurized. Personal injury may result when removing the radiator cap after operating temperature is reached. Do not remove radiator cap when radiator is hot to touch.	

Operator PMCS - Continued

ITEM NO	INTERVAL					ITEM TO BE INSPECTED PROCEDURE: CHECK FOR AND HAVE REPAIRED, FILLED, OR ADJUSTED...	EQUIPMENT IS NOT READY/AVAILABLE IF:
	B	D	A	W	M		
15	●					a. Check for proper coolant level in coolant recovery tank. b. Inspect radiator hoses and clamps for damage, for missing clamps, and for leaks. <u>ENGINE CRANKCASE OIL LEVEL</u> a. Check engine crankcase oil level. Maintain oil level within cross-hatched area on dipstick (between arrows). b. Inspect engine oil filter element for leaks and tightness.	a. Coolant level below ADD: Class III leak exists. b. Hoses/clamps damage, loose, or missing. Class III leak exists. Engine oil level at or below cross-hatched area on dipstick. Class III leak exists.
16	●					<u>COLD START ETHER BOTTLE</u> (Temperature below 30° [1°C]) Check that cold start ether bottle is installed.	Cold start ether bottle missing when temperature is below 30°F (1°C).
17	●					<u>COOLING FAN</u> Inspect fan for loose attaching hardware, cracks, or broken blades.	Fan loose or cracked. Broken blades.
18	●					<u>ENGINE ACCESSORY DRIVE BELTS</u> a. Inspect drive belts for wear, cracks, or fraying. b. Check drive belt tension. Each belt should deflect approx. ½ inch (13 mm) at midspan between pulleys.	a. Drive belts worn, cracked, or frayed. b. Belts loose.
19	●					<u>MUFFLER AND EXHAUST PIPE</u> <div style="text-align: center;">WARNING</div> Ensure exhaust system components are cool to touch. Inspect exhaust system piping for evidence of leaks and corrosion. Check muffler, piping, and guard for security.	Any loose or damaged exhaust system components or evidence of exhaust leak.
20	●					<u>CAB HEATER</u> Check that cab heater fuel tank is full. Inspect heater fuel lines and fittings.	Any fuel leaks.

Operator PMCS – Continued

ITEM NO	INTERVAL					ITEM TO BE INSPECTED PROCEDURE: CHECK FOR AND HAVE REPAIRED, FILLED, OR ADJUSTED...	EQUIPMENT IS NOT READY/AVAILABLE IF:
	B	D	A	W	M		
21	●					<p><u>LOAD MOMENT INDICATING (LMI) SYSTEM</u></p> <p>a. Inspect LMI electrical connectors/wiring for security and damaged insulation.</p> <p>b. Inspect the anti-two block switches and weights for free movement.</p> <p>c. If the auxiliary boom nose is installed, verify that the boom nose anti-two block switch is connected to the junction box on main boom nose.</p> <p>d. If either the main or auxiliary hoist load handling device/wire rope/anti-two block weight has been removed, ensure that the red by-pass flag is installed in the appropriate anti-two block switch.</p> <p>e. Check boom length cable for worn insulation/damage, that it is properly spooled on the reel, and that reel is under tension. Ensure that cable reel is free to rotate.</p> <p>f. Inspect boom angle indicator for damage.</p> <p>g. Inspect pressure transducers and connecting hoses for security and oil leakage.</p>	<p>a. Loose connectors/ wiring or damaged insulation.</p> <p>b. Anti-two block switch damaged.</p> <p>c. Boom nose anti-two block switch disabled/not connected.</p> <p>d. Red bypass flag not installed as required.</p> <p>e. Boom length cable worn/damaged, not spooled properly or cable reel lacks tension.</p> <p>f. Boom angle indicator inoperable.</p> <p>g. Pressure transducers or hoses loose or leaking. Boom angle indicator inoperable.</p>
22	●					<p><u>HYDRAULIC OIL COOLER</u></p> <p>Inspect hydraulic oil cooler for evidence of leaks and dirt/debris restricting air flow through the cooler heat exchanger.</p>	<p>Hydraulic oil cooler contaminated or Class III leak exists.</p>
23	●					<p><u>COUNTERWEIGHT</u></p> <p>Inspect counterweight for loose/ damaged attaching hardware and for cracks or broken welds.</p>	<p>Loose or missing attaching hardware and excessive cracks (more than two detected).</p>
24	●					<p><u>MAIN AND AUXILIARY HOISTS</u></p> <p>a. Inspect hoist hydraulic lines for damage, security, and evidence of leaks.</p> <p>b. Check that wire rope is spooled evenly on both hoist drums. Ensure cable followers are not damaged.</p> <p>c. Inspect hoist mirrors for damage. Ensure each mirror can be seen from cab. (RT875CCS)</p>	<p>a. Any damage, loose, or leaking component: Class III leak exists if required for hoist operation.</p> <p>b. Wire rope not spooled correctly or cable follower(s) damaged for hoist operation</p> <p>c. Hoist mirror(s) damaged or misaligned.</p>

Operator PMCS - Continued

ITEM NO	INTERVAL					ITEM TO BE INSPECTED PROCEDURE: CHECK FOR AND HAVE REPAIRED, FILLED, OR ADJUSTED...	EQUIPMENT IS NOT READY/AVAILABLE IF:
	B	D	A	W	M		
25	●					<u>BATTERY DISCONNECT SWITCH (RT875CCS)</u> Place BATTERY DISCONNECT switch in the on position (key inserted and turned clockwise).	
26	●					<u>EMERGENCY STOWAGE SYSTEM (RT875CCS)</u> Ensure PUMP FUNCTION ON/OFF switch is in the OFF position.	Switch in ON position.
<u>CAB INTERIOR</u>							
27	●					<u>DASH PANEL GAUGES</u> (General Condition) a. Inspect for loose, broken, or cracked lenses. b. Inspect for loose connectors, wiring, and damaged insulation.	Loose connector or wiring. Damaged insulation.
28	●					<u>LIGHTS AND HORN</u> a. With IGNITION switch in RUN position, check all lights for proper operation. b. Depress horn button, horn should sound.	a. Any light inoperable for night operation or crane brake lights inoperable. b. Horn inoperable.
29	●					<u>WIPERS/WASHERS</u> a. Check for proper operation. b. Check fluid level in washer fluid containers. c. Check cab safety glass for cracks and damage.	a. Wiper motor(s) inoperable. c. Safety glass damage that impairs visibility.
30	●					<u>FIRE EXTINGUISHER</u> Check charge indicator. Inspect fire extinguisher for broken or missing seal/lock wire.	Charge indicator in red zone. Seal/lock wire missing on handle.
31	●					<u>SEAT BELT</u> Inspect belt for wear and tears. Check operation of locking device.	Seat belt worn, damaged, or inoperable.
32	●					<u>TRANSMISSION SHIFT LEVER</u> Ensure transmission shift lever operates smoothly through all positions.	Shift lever binds preventing shifting.

Operator PMCS – Continued

ITEM NO	INTERVAL					ITEM TO BE INSPECTED PROCEDURE: CHECK FOR AND HAVE REPAIRED, FILLED, OR ADJUSTED...	EQUIPMENT IS NOT READY/AVAILABLE IF:
	B	D	A	W	M		
33	●					<p><u>DASH PANEL GAUGES AND LMI</u> (Operational Check) Ensure transmission shift lever is in N (neutral) and PARK BRAKE control is set. Start diesel engine and check the following carrier dash panel gauges for operation and proper readings after warm up:</p> <p>● Ensure Load Moment Indicating (LMI) system self checks properly without error codes.</p> <p>● LED alert (RT875CCS). Ensure that LED alert display for emergency steering pump (EMER STEER) lights and stays lit for approximately five seconds after diesel engine starts. If LED fails to light and then go off, there is an indication that the emergency steer pump is not operational. Shutdown diesel engine then repeat PMCS step 33. If LED does not come on, contact maintenance.</p> <p>● a. OIL PRESS gauge. Normal reading is 10 psi (70 kPa) at idle. (35 psi [241 kPa] at high idle and 70 psi [482 kPa] at maximum governed speed).</p> <p>● b. WATER TEMP gauge. Normally pointer is in green area.</p> <p>● c. BATTERY Voltmeter gauge. Normal reading is 24 to 28 volts.</p> <p>● d. TRANS TEMP gauge. Normal reading is 140° F (60° C) to 250 °F (121°C).</p> <p>● e. AIR PRESSURE gauge. Normal reading is 105 (724 kPa) to 120 psi (827 kPa).</p> <p>● f. TACH/HOURS. Ensure that needle moves when throttle is depressed.</p>	<p>LMI system does not pass self test for maritime operation or if boom angle indicator is inoperative.</p> <p>LED fails to light and then go off after approximately five seconds.</p> <p>a. Oil pressure lower than 10 psi (70 kPa).</p> <p>b. Gauge reads in red area.</p> <p>c. Gauge reads outside of limits.</p> <p>d. Gauge reads outside of limits.</p> <p>e. Gauge reads outside of limits.</p> <p>f. TACH/HOURS meter is inoperative.</p>
34	●					<p><u>THROTTLE LINKAGE</u> Check that throttle operates smoothly through full range and is indicated properly on tachometer.</p>	<p>Operation is rough or linkage binds.</p>
35	●					<p><u>DIESEL ENGINE</u> With diesel engine running at normal operating temperature, check for fuel, oil, and coolant leaks.</p>	<p>Any fuel leaks or Class III oil or coolant leaks.</p>

Operator PMCS - Continued

ITEM NO	INTERVAL					ITEM TO BE INSPECTED PROCEDURE: CHECK FOR AND HAVE REPAIRED, FILLED, OR ADJUSTED...	EQUIPMENT IS NOT READY/AVAILABLE IF:
	B	D	A	W	M		
36	•					<p><u>TRANSMISSION</u></p> <p style="text-align: center;"><u>CAUTION</u></p> <p>Maintaining the torque converter at full throttle stall speed for an extended period of time will overheat the torque converter.</p> <p style="text-align: center;"><u>NOTE</u></p> <p>Do not attempt to check transmission oil level when oil is cold.</p> <p>In cold weather, it may be necessary to stall the torque converter in order to reach the required oil temperature as follows:</p> <ol style="list-style-type: none"> a. With diesel engine running, level the crane by raising the outriggers. b. Apply parking brake. c. Place transmission shift lever to forward (F) and high range. d. Accelerate engine to between 1500 and 1800 rpm. e. Hold converter stalled until transmission oil temperature is between 180 and 200° F. <p>With the diesel engine running, check for correct transmission oil level on dipstick. Maintain between "add" and "full" marks on dipstick. Add transmission oil through fill pipe if necessary.</p>	Class III leak exists.
37	•					<p><u>HYDRAULIC RESERVOIR</u></p> <p>With diesel engine running at normal operating temperature, check condition of hydraulic oil filter indicator on filter head. Indicator reading in the red area indicates fouled element.</p>	Hydraulic oil filter indicator in red area.
38	•					<p><u>BACKUP ALARM</u></p> <p>With PARK BRAKE applied and diesel engine at idle, place transmission shift lever in R1 and verify that backup alarm sounds.</p>	Backup alarm inoperable or no ground guide available for backing operation.

Operator PMCS – Continued

ITEM NO	INTERVAL					ITEM TO BE INSPECTED PROCEDURE: CHECK FOR AND HAVE REPAIRED, FILLED, OR ADJUSTED...	EQUIPMENT IS NOT READY/AVAILABLE IF:
	B	D	A	W	M		
39	●					<p><u>SERVICE AND PARKING BRAKES</u></p> <p>NOTE</p> <p>Ensure outriggers are retracted.</p> <p>a. Check park brake operation with PARK BRAKE control pulled, diesel engine at idle, and transmission in gear, check for forward and reverse motion of vehicle.</p>	a. Any crane movement with park brake applied.
40	●					<p>b. Service brakes. Check/listen for noise and stopping ability with crane moving slowly (in either direction) when depressing brake foot pedal.</p>	b. Chattering, grinding, or inability to stop.
41	●					<p><u>FRONT AXLE STEERING</u> Check front axle steering for smooth and proper operation.</p>	Steering wheel binds or turns rough.
42	●					<p><u>REAR AXLE STEERING</u> Check rear axle steering for smooth and proper operation.</p>	Rear STEER lever binds or rear wheels turn rough.
43	●					<p><u>SWING BRAKE</u></p> <p>CAUTION</p> <p>Ensure hook block is removed from its tiedown point and that swing lock control lever and SWING BRAKE control are disengaged.</p> <p>a. Disengage swing lock control lever. b. Pull out SWING BRAKE control knob to disengage swing brake. c. Check for proper operation of SWING control lever and swing brake pedal.</p> <p>d. Depress SWING BRAKE control knob to engage swing brake and verify that SWING control lever does not rotate the boom.</p>	<p>c. Boom continues to rotate with swing brake pedal depressed. Chattering and grinding, or inability to stop boom rotation. d. Boom swings in either direction with swing brake engaged.</p>

Operator PMCS - Continued

ITEM NO	INTERVAL					ITEM TO BE INSPECTED PROCEDURE: CHECK FOR AND HAVE REPAIRED, FILLED, OR ADJUSTED...	EQUIPMENT IS NOT READY/AVAILABLE IF:
	B	D	A	W	M		
44	•					<p><u>OUTRIGGERS</u></p> <p>a. Extend front and rear outrigger beams.</p> <p>b. Inspect outrigger beams for cracks and damage.</p> <p>c. Install outrigger floats.</p> <p>d. Lower outrigger jack cylinders and level crane.</p> <p>e. Retract outriggers/stow outrigger floats (if not required for operation).</p>	Outriggers damaged or inoperative.
<p>WARNING</p> <p>The following procedure checks the operation of the LMI system. Use care to prevent damage to the crane or injury to personnel. If the crane operator cannot see the load handling device (hook block and/or bottom lift sling), use a spotter to monitor the load handling device. The crane operator should be prepared to stop operation immediately should the LMI not function properly to lockout an unsafe condition.</p>							
45	•					<p><u>MECHANICAL BOOM ANGLE INDICATOR (AND LMI LOCKOUT FEATURE)</u></p> <p>a. Program the LMI. Refer to page 2-46.</p> <p>b. Check the LMI for proper operation. Manually lift the weight attached to the anti-two block switch. An alarm should sound and a light should come on.</p> <p style="text-align: center;">NOTE</p> <p>While raising boom, verify that mechanical angle indicator moves from 0 to 70° without sticking or binding.</p> <p>c. Slowly raise hook block to verify that an alarm sounds and a light comes on when it comes in contact with the weight attached to the anti-two block switch. An alarm should sound and a light should come on. The boom lift function should stop (lock out). Lower the hook block to eliminate the potential two-block condition.</p>	<p>b. Mechanical boom angle indicator is inoperative, missing, or binds/ sticks if LMI inoperable.</p> <p>c. LMI fails to lock out crane function if mechanical boom angle indicator is inoperative.</p>

Operator PMCS – Continued

ITEM NO	INTERVAL					ITEM TO BE INSPECTED PROCEDURE: CHECK FOR AND HAVE REPAIRED, FILLED, OR ADJUSTED...	EQUIPMENT IS NOT READY/AVAILABLE IF:
	B	D	A	W	M		
46	●					d. Slowly telescope the boom to create a potential two-block condition. An alarm should sound and a light should come on. The boom telescope function should stop (lock out). Lower the hook block slightly to eliminate the potential two-block condition. e. Verify that the LMI display of the boom length agrees with the actual boom length. f. Verify that the LMI display of boom angle agrees with the mechanical boom angle indicator. g. Verify that the LMI display of boom radius agrees with the actual boom radius. h. Verify that the LMI display for load weight agrees with the known actual weight. <u>MAIN AND AUXILIARY HOISTS</u> Check for proper operation by raising and lowering the hook block several times. Ensure hoist motors and hoist brakes operate smoothly.	Chattering or roughness detected in hoist operation.
47	●					<u>WIRE ROPE</u> a. Inspect wire rope, rope sockets, and fittings for damage, wear, corrosion, heat damage, and lack of lubrication on rope. Check for kinks and exposed/ broken wire strands. Ensure that all components are properly reeved and secure. b. Inspect sheave guards, guides, drums, flanges, and other surfaces that come in contact with wire rope for sharp edges, burrs, and corrosion that could damage wire rope.	a. Refer to page 2-39 for wire rope safety criteria. If in doubt, contact maintenance. b. Any component damaged and/or corroded to the extent of inflicting damage to the wire rope.
48	●					<u>BOOM</u> a. Inspect boom for cracked or broken welds and bends/distortion of boom base and telescoping sections. b. Inspect boom sliding surfaces for evidence of worn/damaged/missing wear pads. Also check for proper lubrication.	a. Cracked or broken welds or distortion exists. b. Worn, damaged, loose, missing, or unlubricated wear pads.

Operator PMCS - Continued

ITEM NO	INTERVAL					ITEM TO BE INSPECTED PROCEDURE: CHECK FOR AND HAVE REPAIRED, FILLED, OR ADJUSTED...	EQUIPMENT IS NOT READY/AVAILABLE IF:
	B	D	A	W	M		
49	●					<p><u>BOOM SHEAVES AND HOOK BLOCK</u></p> <p style="text-align: center;">WARNING</p> <p>Do not touch sheave edge.</p> <p>a. Inspect boom sheaves and hook block to ensure all components are properly installed and secure.</p> <p>b. Inspect hook block for cracks, damage, and deformed hook. Check for damaged/ missing safety latch.</p>	<p>a. Any component loose, damaged, or not installed properly.</p> <p>b. Hook block cracked, damaged, or deformed. Safety latch damaged/ missing.</p>
50	●					<p><u>OVERHAUL BALL</u> Inspect overhaul ball for cracks, damage, and deformed hook. Check for damaged/ missing safety latch.</p>	<p>If required for operation: overhaul ball cracked, damaged, or deformed. Safety latch damaged/ missing.</p>
51	●					<p><u>BOTTOM LIFT SLING (RT875CCS)</u> (If required for operation) Inspect bottom lift sling for damage or loose/missing parts. Ensure that lift sling is properly rigged and attached to the hook block.</p>	<p>Any physical damage, loose or missing parts. Bottom lift sling not properly secured to hook block.</p>
52	●					<p><u>REAR AXLE LOCKOUT SYSTEM</u> Check rear axle lockout system for proper operation.</p>	<p>Rear axle lockout system fails test.</p>
53		●				<p><u>PANEL GAUGES, INDICATORS, LMI</u> Continually monitor all panel gauges, indicators, and the LMI console for operation and normal readings.</p>	<p>Panel gauges or LMI fail during operation or readings not normal.</p>
54		●				<p><u>AIR SYSTEM RESERVOIRS</u> Check for air leaks, corroded fittings, and proper air pressure gauge reading (105 to 120 psi [724 to 827 kPa]).</p>	<p>Air pressure less than stated. Air leaks detected.</p>
55		●				<p><u>BOTTOM LIFT SLING (RT875CCS)</u> Check bottom lift sling connection to hook block periodically during craning operations.</p>	<p>Attaching hardware loose or damaged.</p>
56			●			<p><u>SUSPENDED LOADS</u> Ensure that all suspended loads have been lowered to the ground before shutting down the crane.</p>	<p>Any load left suspended and unattended.</p>

Operator PMCS – Continued

ITEM NO	INTERVAL					ITEM TO BE INSPECTED PROCEDURE: CHECK FOR AND HAVE REPAIRED, FILLED, OR ADJUSTED...	EQUIPMENT IS NOT READY/AVAILABLE IF:
	B	D	A	W	M		
57			●			<p><u>BATTERY DISCONNECT SWITCH (RT875CCS)</u> Ensure BATTERY DISCONNECT switch is in off position (key removed).</p>	
58			●			<p><u>CRANE</u> Conduct overall post-operation inspection for leaks and physical damage.</p>	Any fuel or Class III leaks. Any physical damage that could impair operation.
59				●		<p><u>AIR SYSTEM AND PARK BRAKE RELAYS</u> Check for proper operation:</p> <ol style="list-style-type: none"> a. Chock wheels and fully charge the air system. Adjust service brakes. b. Apply and release the service brakes several times and check for prompt response of the brakes at the wheels. <p>Perform leakage test:</p> <ol style="list-style-type: none"> a. With dual brake valve in brake released position, coat exhaust port with soap solution to check for inlet valve and O-ring leakage. A 1 in. (2.54 cm) bubble in five seconds is permitted. b. Place dual brake valve in brake-applied position and check at exhaust port for leakage of exhaust valve. Apply soap solution around valve where cover joins body to check for seal ring leakage. A 1 in. (2.54 cm) bubble in three seconds is permitted. c. With dual brake valve still in brake applied position, apply soap solution to quick release exhaust port on R-12 valve to check diaphragm exhaust seat, and to valve body in area where the cover joins body on R-12 valve, to check for O-ring leakage. No leakage is permitted. 	Operation is rough or linkage binds.
60					●	<p><u>CAB HEATER (RT875CCS)</u> Start up and operate the cab heater for a short period of time during the warm season to help prevent varnish buildup caused by evaporating fuel.</p>	

Section III – OPERATION UNDER USUAL CONDITIONS

GENERAL SAFETY PRECAUTIONS

It is impossible to compile a list of safety precautions covering all situations. However, there are basic safety precautions that **MUST** be followed during your daily routine. Safety is **YOUR PRIME RESPONSIBILITY**, since any piece of equipment is only as safe **AS THE PERSON AT THE CONTROLS**.

With this thought in mind, this section of the operator's manual will assist you, the operator, in promoting a safe working atmosphere for yourself and those around you. It is not meant to cover every conceivable circumstance that could arise. It is intended to present basic safety precautions that should be followed in daily operation.

Because you, the operator, are the only part of the crane that can think and reason, your responsibility is not lessened by the addition of operational aids or warning devices. Indeed, you must guard against acquiring a false sense of security when using them. They are there to assist, **NOT** direct the operation. Operational aids or warning devices can be mechanical, electrical, electronic, or a combination thereof. They are subject to failure or misuse.

You, the operator, are the only one who can be relied upon to assure the safety of yourself and those around you. Be a **PROFESSIONAL** and follow the **RULES** of safety.

REMEMBER, failure to follow just one safety precaution can cause that accident to people or equipment.

You are responsible for the safety of yourself and those around you.

Ensure you and those working with you are aware of any special dangers where you are operating the crane. Be especially careful of dangerous ground and objects, including buildings, near the crane.

Be aware at all times that you are responsible for the safety of yourself, your co-workers, the crane and everything around it. Make certain the crane is properly maintained, and then pay attention to winds, boom deflections, rope sway, and any unusual things, which you, as a crane operator, may notice which would not be important to others.

Know and abide by the basic safety rules.

Read and understand the Operator's Manual before entering the cab. Follow directions on all placards. Know what they mean and follow their instructions.

Operators must be thoroughly familiar with safe crane operating practices and have a complete understanding of all operation and maintenance instructions provided. Operators should be physically fit and thoroughly trained, with related experience, not be easily excitable, not be subject to epileptic seizures, and not be using any drug that could impair physical, visual, or mental reactions or capabilities.

Wear the proper clothing for the job. Wear personnel protective equipment as required by local or job regulations.

Inspect the crane every day (before the start of each shift). Ensure that routine maintenance and lubrication are being dutifully performed. Don't operate a damaged or poorly maintained crane. You risk lives when operating faulty machinery, including your own.

Know the area in which you are working. Familiarize yourself with work site and other potential hazards in the area.

Use caution when in the vicinity of overhanging banks or edges.

Keep your shoes clean. Before entering the cab, clean any mud or grease from your shoes. This will reduce the possibility of your foot

slipping off a control pedal, possibly resulting in an accident.

Since certain shoe sole materials are more slip resistant than others, all operating and service personnel should wear footwear with high slip resistant sole material.

Avoid a dirty or greasy crane. Keep the cab, deck, and foot and hand holds free of mud and grease for operator safety. Dirty equipment fails rapidly and makes good maintenance difficult.

Observe and heed possible pinch points while performing checks and services.

Unless authorized and approved by U.S. Army Tank Automotive Command, do not make any modifications, alterations, or changes to a crane which could in any way affect its original design. Such action invalidates all warranties and capacity charts, and makes the owner/user liable for any resultant accidents.

Keep the crane properly maintained and adjusted at all times. Shut down the crane while making repairs or adjustments.

Keep your fingers away from potentially hazardous areas.

Always perform a function check after repairs have been made to ensure proper operation. Load test should be performed when structural or lifting members are involved.

Do not store flammable materials on the crane at any time.

Never get off (or on) a moving crane.

When getting on or off a stationary crane, use both hands and use handrails and steps provided.

Allow NO ONE other than the operator to be on the crane while the crane is functioning or moving.

PREPARATION FOR USE/SERVICE UPON RECEIPT

BEFORE TURNING ON IGNITION SWITCH

The crane is shipped ready for use, i.e., all engine oil, transmission oil, hydraulic oil and axles are ready for service.

1. Remove all packing materials securing the cab door. Remove all protective material in the cab. Remove cushioning and tape around LMI console, defroster fan, and load chart.
2. Remove straps securing tool box.
3. Remove fire extinguisher. Remove fire extinguisher packing materials and install fire extinguisher in the cab.
4. Check and adjust all outside mirrors. Including hoist rotation mirrors (RT875CCS)
5. Unpack and install hook block.
6. If required for immediate use, unpack and install overhaul ball.
7. Remove dummy plug in junction box on main boom nose and connect auxiliary boom nose anti-two block switch to junction box.
8. Service all lubrication points in accordance with LO 5-3810-306-12.
9. Service fuel tank.
10. Perform all B (before) and W (weekly) PMCS.
11. Install Quick Start Bottle.

ENGINE OPERATION

The following starting and shutdown procedures should be used to operate engine.

STARTING PROCEDURE

WARNING

Hearing protection required when operating the crane.

WARNING

Before starting diesel engine, ensure that parking brake is applied and swing lock is engaged.

CAUTION

Never crank engine for more than 30 seconds during an attempted start. If engine fails to start after 30 seconds, allow starter motor to cool for approximately two minutes before attempting another start.

If engine fails to start after four attempts, correct the malfunction before attempting any further starts.

NOTE

Engine will not crank unless transmission gearshift lever is in neutral (N) position.

1. Position IGNITION switch to ON and depress ENGINE START pushbutton.
2. After engine starts, check engine instruments for proper indications as follows:

Trans. Oil Temp.	180-250° F (82-121° C)
Eng. Water Temp.	175-185° F (79-85° C)
Eng. Oil Press. (min)	
Idle	10-30 psi (70-210 kPa)
Rated	60-70 psi (420-490 kPa)
Air Pressure	105-120 psi (724-827 kPa)

CAUTION

If oil pressure and/or temperature gauge(s) do not display proper readings, shut down the engine and correct the malfunction before resuming operation.

3. Allow engine and hydraulic oil to warm up at least five minutes before applying a load.
4. Perform all During (D) PMCS procedures.

SHUTDOWN PROCEDURE

1. Return crane to travel mode.

- a. Retract boom and swing boom over the front.
 - b. Lower boom to horizontal.
 - c. Raise and retract outriggers. Stow outrigger floats
2. Put all controls in neutral.
 3. Set parking brake and swing lock.
 4. Allow diesel engine to fast idle speed (1000 to 1200 RPM) for approximately five minutes to avoid high internal heat rise and allow for heat dissipation.
 5. Position IGNITION switch to OFF.
 6. Chock wheels.

CRANE TRAVEL OPERATION

PREPARATION FOR TRAVEL

1. Ensure crane is in travel mode. Strictly adhere to the following superstructure conditions before moving the crane whether under its own power or when being towed. Procedures for accomplishing the following are located in various sections of this manual.
 - a. Fully retract boom.
 - b. Swing boom over the front. Lower boom to horizontal.

WARNING

Do not drive the crane with the boom off center. Automatic oscillation lockout will occur, making the crane subject to tipping on uneven surfaces.

Do not drive the crane with the lift cylinders bottomed. Position the boom to horizontal.

- c. Push SWING BRAKE control knob. Engage mechanical swing lock by pushing down on SWING LOCK control handle.
- d. Remove hook block and/or overhaul ball from hoist cable(s). Stow them securely before traveling, or ensure hook block or

overhaul ball is properly secured to tie down provided.

- e. Ensure outrigger stabilizers and outriggers are fully retracted and outrigger floats are removed.
- f. Ensure all four (4) outrigger floats are properly stowed.

CAUTION

Do not engage or disengage hydraulic pump with engine running. Otherwise, damage to pump and drive could occur.

- 2. Disengage hydraulic pump at pump disconnect lever.
- 3. Check cold tire pressure (75 psi).

NOTE

Do not attempt to move crane until brake system air pressure is at normal operating level (approximately 75 psi).

- 4. Before traveling, check suitability of proposed route with regard to crane height, width and length. Ensure that all required permits are on board.

TRAVEL SAFETY PRECAUTIONS

- 1. Due to highway requirement of non-permanently attached components and items, the bottom lift sling must be removed from the on board storage cradle and shipped separately in the stowage tray provided with the bottom lift sling before transporting the crane (see Appendix G).
- 2. Tire Temperatures – After every one hour of travel time, stop and allow tires to cool off 30 minutes.
- 3. Terrain – You should be cautious when moving over rough terrain.
- 4. Traction – Use four-wheel drive only when greater traction is necessary. (Refer to FOUR-WHEEL DRIVE OPERATION, for operating instructions.)
- 5. Bridges – Check load limit of bridges. Before traveling across bridges, ensure they

will carry a load greater than the crane’s weight.

- 6. Clearances. Watch clearances when traveling. Do not take a chance of running into overhead or side obstructions.

When moving in tight quarters, post a look-out to help guard against running into objects.

Never back up without the aid of signalman. He should assure that the area behind the crane is clear of objects and/or personnel.

- 7. Traffic - When traveling, keep lights on, use traffic warning flags and signs, and use front and rear flag vehicles. Check state and local restrictions and regulations.

Drive carefully and avoid speeding.

- 8. Towing - Should the crane become mired down, use a tow truck or tractor to free the crane. The transmission or axles can be damaged if you attempt to free the crane without help.

On open ground, tow or pull using only the pintle hook or the two tow lugs installed on each end of the crane. When using tow lugs, always tow using a towbar conforming to MS50048, heavy duty capacity.

Contact Organizational Maintenance to disconnect the front drive line before towing the crane. Ensure the drive axle selector is at 2WD-HI, to lockout the rear drive line.

STEERING

Steer the front wheels by turning the steering wheel and steer the rear by pushing/pulling the STEER control lever. Used singly or together, these controls provide:

- 1. Front Wheel Steering. The steering wheel controls the front wheels. This method of steering should always be used when traveling at higher speeds. Turning the wheel clockwise steers the crane to right. Turning the wheel counterclockwise steers the crane to the left.

CAUTION

Use rear steering only on the job site.

2. Rear Wheel Steering. Rear wheel steering is controlled by the STEER control lever. Pushing or pulling the control lever moves the rear steer cylinders.
 - a. To steer the rear of the crane to the left, push STEER lever forward.
 - b. To steer the rear of the crane to the right, pull STEER lever.
 - c. Four Wheel Steering. Four-wheel steering is performed using the steering wheel and STEER control lever. Four-wheel steering requires turning the front and rear wheels to steer the front and rear of the crane in the same direction. The effect is in a tighter turning radius that will enable you to work the crane in close when necessary.
 - d. Crabbing. Crabbing implies turning the front and rear wheels to steer the front and rear of the crane in opposite directions (i.e., if the front wheels are steered left, then the rear wheels are steered right). The effect of crabbing is the crane moves in a diagonal direction, enabling you to work the corners of crane in close when necessary.

MOVING THE CRANE - FORWARD

1. Position DRIVE AXLE selector switch to either 2WD-HI or 4WD-LO.
2. Position transmission shifting lever to first gear (1) position.
3. After engine warmup, shift transmission directional control lever from neutral (N) to forward (F) position. Release parking brake and depress foot throttle pedal until maximum gear speed is attained.
4. Shift transmission lever to second gear (2) position; accelerate until maximum gear speed is attained.
5. Shift to third gear (3) position and accelerate to desired travel speed.

CAUTION

Do not downshift to a lower gear if crane is traveling at a greater road

speed than the maximum speed of the lower gear.

MAXIMUM SPEED (MPH)

SPEED SELECTOR POSITION	<u>Hydraulic Pump Engaged</u>	
	<u>4WD LO</u>	<u>2WD HI</u>
1	1.4	3.8
2	2.8	7.9
3	7.6	19.9
	<u>Hydraulic Pump Disengaged</u>	
	<u>4WD LO</u>	<u>2WD HI</u>
1	1.4	3.8
2	2.8	8.0
3	7.6	20.1

MOVING THE CRANE IN REVERSE

CAUTION

Apply the service brakes and bring the crane to a complete stop before shifting transmission direction control lever to R (reverse).

Moving the crane in reverse requires the same steps as moving forward except for Step 3 where the transmission direction control lever is placed to F (forward). Place the lever to R (reverse).

FOUR-WHEEL DRIVE OPERATION

If more traction is required due to slipping or spinning wheels, engage rear axle four-wheel drive. Engage four-wheel drive as follows:

CAUTION

Before shifting from two-wheel drive to four-wheel drive (or from four back to two) the crane must be standing still.

1. Place transmission shift lever to N (neutral).
2. Position DRIVE AXLE selector switch to 4WD LO.
3. Select gear speed and direction of travel as described under MOVING THE CRANE - FORWARD.
4. Return DRIVE AXLE selector switch to 2WD HI as soon as conditions allow.

PARKING

WARNING

Always set parking brake when transmission is disengaged.

1. Stop crane with service brakes.
2. Move transmission shift lever to N (neutral)
3. Set parking brake.
4. If parked on a hill, chock wheels.

WARNING

After moving the crane, allow tires to cool before lifting any loads with the outriggers retracted (i.e., on rubber). Failure to follow this warning could result in a tire exploding causing personnel injury and/or equipment damage.

CRANING OPERATIONS

GENERAL SAFETY PRECAUTIONS

Most accidents involving mobile hydraulic cranes are caused by:

- crane out of level,
- bad surface conditions,
- outriggers used improperly or not used at all,
- unstable blocking under outrigger floats, and
- improper crane operation.

Don't interfere with the proper operation of aids and/or warning devices. Check them regularly and see they get proper care.

Operate engine at full governed RPM (2500) during performance of all crane operations.

Watch tail-swing of counterweight, especially if there are personnel or obstacles in the area.

Stay clear of sheaves, holes in telescoping boom and other potentially dangerous areas whenever the crane is in operation.

Pinch points are impossible to eliminate. Keep all portions of your body away from cable drums, sheaves, pulleys, lift cylinders and other moving parts of the crane.

Never operate the crane with less than one complete layer of rope on the hoist drum.

NEVER permit anyone to ride load, slings, hooks, etc., for any reason.

Allow no one to ride on the crane, carrier deck, engine compartment, etc.

Operate the crane only from the operator's seat. Operating from any other position, such as reaching in a window, creates a safety hazard.

Never work the crane when darkness, fog or other visibility problems make such operating unsafe.

Always check capacity of the crane as shown on load chart before making any lifts.

Report any crane damage immediately. Do not operate crane until inspected and approved for use.

ESTABLISHING A SIGNAL PERSON

A qualified signal person should be on site at all times when:



- working in vicinity of power lines,
- you cannot clearly see the load at all times, and
- moving the crane in direction in which you cannot clearly see the path of travel.

Use the standard hand signals shown below. If communication between you and your signal person is lost, stop craning operations until the problem is cleared up.

Watch the load at all times. Watch signal person and/or load while it is moving. In case you must look in another direction, stop operation immediately.

Use only one qualified signal person whenever your vision is blocked and follow his directions.

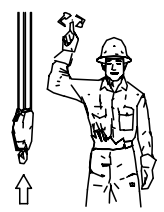
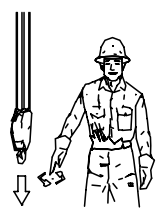
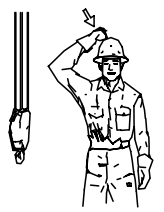
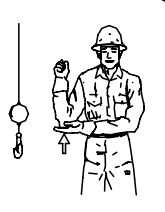
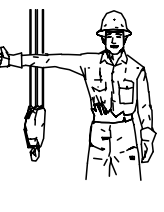
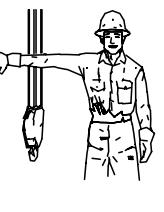
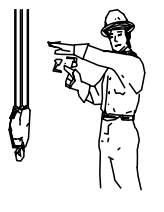
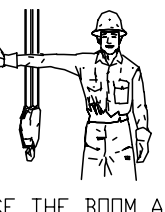
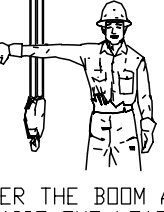
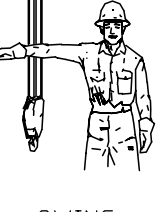
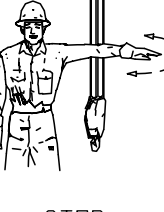
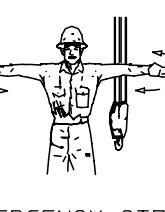
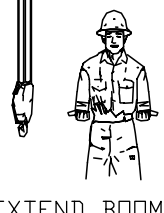
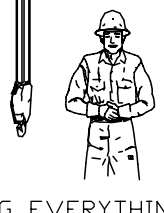
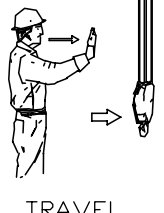
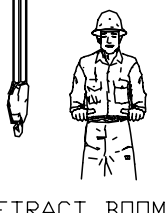
But...
OBEY A SIGNAL TO STOP FROM ANYONE.

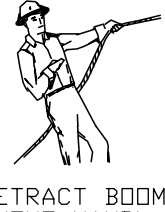
 ↑ HOIST	 ↓ LOWER	 USE MAIN HOIST	 USE WHIP LINE (Auxiliary Hoist)
 RAISE BOOM	 LOWER BOOM	 MOVE SLOWLY	 RAISE THE BOOM AND LOWER THE LOAD
 LOWER THE BOOM AND RAISE THE LOAD	 SWING	 STOP	 EMERGENCY STOP
 EXTEND BOOM	 DOG EVERYTHING	 TRAVEL	 RETRACT BOOM
 EXTEND BOOM (ONE HAND)	 HAND SIGNALS <small>Reprinted by permission of The American Society of Mechanical Engineers</small>		 RETRACT BOOM (ONE HAND)

WIRE ROPE AND SHEAVES SAFETY PRECAUTIONS

Always make daily inspections of wire rope and replace worn, rusty or frayed ropes. The following information is taken from a National Consensus Standard as referenced by Federal Government Agencies.

All wire rope will eventually deteriorate to a point where it is no longer useable. Wire rope shall be taken out of service when any of the following conditions exist:

1. In running ropes, six randomly distributed broken wires in one lay or three broken wires in one strand in one lay.
2. Wear of one-third the original diameter of outside individual wires.
3. Evidence of heat damage from any cause.
4. Reductions from nominal diameter more than 3/64 inch for 3/4 diameters.

How to measure or caliper a wire rope (allowable limits -0 + 5%)

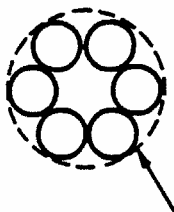

A. "TRUE" DIAMETER

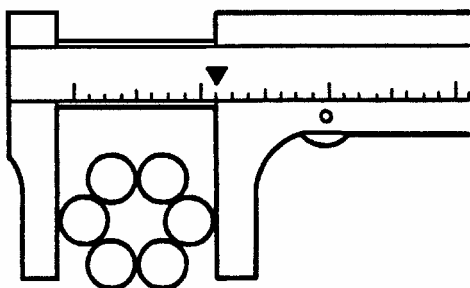

B. CORRECT

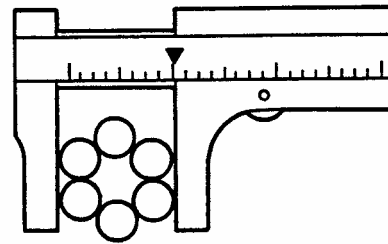

C. INCORRECT

To measure wire rope correctly, always measure the larger dimension. *Measurement methods are for 1/4" (6.35mm) and larger wire rope.

5. In standing ropes, more than two broken wires in one lay in sections beyond end connections or more than one broken wire at an end connection.
6. Crushing - Because of loose windings on a drum, rope was pulled between laying wraps of wire rope and crushed when the loose wraps were tightened.
7. Birdcaging - Sudden release of a load causing birdcaging. Birdcaging is strands open/pulled away from each other displaying the core.
8. Locking, Corrosion, Pitting and Abrasion - Lack of lubrication, premature breaking of wires, excessive dirt, sand or gravel embedded in the strands of the wire rope.
9. Reverse Bending - Caused by running the wire rope over one sheave and under another sheave.
10. Pinch - Caused by undersized sheave grooves; breaking wire strands.

Refuse to work with worn or damaged wire rope.

Never handle wire rope with bare hands.

Use the wire rope that is specified in TM 5-3810-306-24P.

Sheaves, guards, guides, drums, flanges and other surfaces that come in contact with rope

should be inspected for conditions that could cause possible damage to rope.

Inspect the boom nose and hook block sheaves for wear. Damaged sheaves cause rapid deterioration of wire rope.

USE ENOUGH PARTS OF LINE FOR HEAVY LIFTS AND CHECK ALL LINES, SLINGS AND CHAINS FOR CORRECT ATTACHMENT. To obtain maximum lifting capacities, hook block must be set up with enough parts of line. **NO LESS THAN ONE LAYER** of wire rope should remain on hoist drum. When slings, ties, hooks, etc., are used, make certain they are correctly positioned and secured before raising or lowering the loads.

Ensure the wire rope is properly routed. If not properly routed, notify Organizational Maintenance.

Two-blocking **MUST BE AVOIDED** to prevent damage to the crane and to avoid creating a safety hazard. Two-blocking occurs when the hook block, overhaul ball, rigging, etc. contact the boom nose or auxiliary boom nose. Two-blocking can damage the wire rope rigging, reeving, and other crane components. These parts become highly stressed and overloaded until the wire rope fails allowing load, block, etc. to free fall.

The anti-two block protection of the LMI system is provided by the anti-two block switches for the main and auxiliary hoists. When wire rope is reeved and a load-handling hook is present on both the main and auxiliary hoists, both anti-two block switches are used to provide anti-two block protection. If the auxiliary boom nose has been removed, a jumper/dummy plug must be installed in the boom nose junction box and only the main hoist anti-two block switch is used to provide anti-two block protection. If there is no wire rope reeved, no load handling hook present, and the anti-two block switch weight has been removed for either the auxiliary or main hoist, the red by-pass flag must be installed in the nose of the respective anti-two block switch, securing the chain. Without the red by-pass flag installed in the anti-two block switch, the switch will be activated and crane

functions will be locked out by the LMI control lever lockout system.

WARNING

The crane is equipped with an anti-two-block warning system. Ensure that both anti-two block switches are functional prior to operating the crane. Failure to follow this procedure could result in personal injury and equipment damage.

Use the red by-pass flag (plug) to disable/deactivate an anti-two block switch **ONLY** if wire rope and load-handling device have been removed on a particular boom nose (main or auxiliary). Be sure to remove the red flag when the wire rope and load handling device have been reinstalled.

When lowering or extending the boom, let out cable to prevent two-blocking the boom nose and the hook block. The closer the load is carried to the boom nose, the more important it becomes to let out cable as the boom is lowered. Keep hook block, etc. at least 12 inches (30.48 cm) away from boom nose at all times.

ENSURING CRANE IS STABLE

Ensure crane is stable before lifting a load.

Ensure outriggers (or tires if lifting on rubber) are placed firmly on solid ground. Ensure crane is level, brakes are set and load is properly rigged and attached to the hook block. Lift load slightly off the ground then recheck stability before proceeding with the lift. Wind and other factors such as boom length, boom angle, size and weight of load being lifted, etc. can affect crane stability. You should establish safe working loads for each job depending on conditions that exist at the time. Capacity reductions shall be made when conditions indicate the crane could be damaged or become unstable. Be cautious if the wind speed reaches 20 miles per hour (32 kph).

KEEP THE BOOM SHORT Swinging loads with the boom extended can cause boom damage and an unstable crane.

ELECTRICAL HAZARDS

Read and observe the WARNING plates posted in and on the crane.

Crane operation is extremely dangerous when close to an electrical power source.

Use extreme care when operating near an energized power source or power lines.

Assume all power sources are hot.

When operating near power lines, have the power company cut off the power and ground the lines.

Obey the following rules at all times, whether power is cut off or not.

- Move the crane away from power sources.
- Ensure that no part of the crane or load comes closer than the minimum clearances allowed below.
- Get assurance that power has been turned OFF.

IMPORTANT - Always consider wire rope, hoist cable, pendant cables, tag lines, etc. as electrical conductors.

EXERCISE EXTREME CAUTION AND PRUDENT JUDGEMENT WHENEVER ELECTROCUTION HAZARDS EXIST - OPERATE SLOWLY AND CAUTIOUSLY.

Comply with all federal, state, and local laws and regulations.

REMEMBER you do not have to touch a power line or power source to become electrocuted. Electricity can jump from the power line into the crane. "Low" voltages can also be dangerous.

Keep all parts of crane (ropes, hook block and load) at least:

Power Source	Min Clearance
Under 50 KV	- 10 FEET
69 KV	- 12 FEET
115-161 KV	- 15 FEET
230-285 KV	- 20 FEET
345 KV	- 25 FEET
500 KV	- 35 FEET

Whenever a load, wire rope, boom or any portion of a crane contacts or approaches too closely to an electrical power source, everyone in, on and around the crane can be seriously injured or killed!

THE ONLY SAFE WAY TO OPERATE A CRANE IS TO STAY AWAY FROM ELECTRICAL SOURCES!

Appoint a signal person, equipped with a loud signal whistle or horn and voice communication equipment, to warn you when any part of the crane or load is near a power source. This person should have no other duties while the crane is working.

Warn all personnel of danger. Keep unnecessary personnel away from the working area. Permit no one to lean against or touch the crane. Permit no one including sling men or load handlers to hold load, lines or rigging gear.

Even if you are not affected by an electrical contact, others in the area may become seriously injured or killed.

The use of boom guards, proximity devices, insulated hooks, links or mechanical limit stops do not assure safety. Even if codes or regulations require use of such devices, failure to follow rules listed here may result in serious injury or death. You should be aware of some of the limitations of devices.

Boom cage/guards afford limited protection from electrocution. They are designed to cover only boom-nose/ point and a portion of the boom. Boom cages/guards are limited by their physical lengths, insulating abilities and operating conditions (e.g., dust, dirt, moisture, etc.).

Insulating links installed into the load line afford limited protection for those handling the load. Links have limited lifting, insulating and other properties that affect their performance. Moisture, dust, dirt, oils, etc. can cause a line to conduct electricity. Due to their capacity/ratings, some links are not effective for large cranes and/or high voltages/currents.

The only protection afforded by a link is that which is obtained below the link -- electrically downstream, provided the link has been kept clean and free of contamination and is tested prior to use for its non-conducting capability.

Proximity sensing devices are available in different types. Some use boom nose (localized) sensors and others use full boom length sensors. No warning may be given for components, cables, loads, etc. located outside of the sensing area. Responsibility is on you, the operator, in selecting and properly setting sensitivity of these devices.

Never rely solely on a device to protect you and your fellow workers from danger!

Some variables which you must be aware of are:

1. Proximity devices detect the existence of electricity -- not it's quantity or magnitude.
2. Some proximity devices will detect only alternating current (AC) -- not direct current (DC).
3. Some devices detect radio frequency (RF) energy -- others do not.
4. Most proximity devices simply provide a signal (audible, visual or both) -- the signal must not be ignored.
5. Proximity devices often become confused by complex or differing arrays of power lines/sources.

Plan ahead and plainly mark a safe route before traveling under power lines. Erect rider poles on each side of the crossing to assure sufficient clearance is maintained.

Overhead lines tend to blow with wind. Allow for this when determining safe operating distances.

DO NOT store material under power lines or close to electrical power sources.

Grounding the crane offers little or no protection from electrical hazards. The grounding effect is limited by the wire size used, the condition of

the ground, amount of voltage and current present, etc. Power source contacts have been known to cause serious arcing due to grounding.

Tag lines should always be made of non-conductive materials.

Any tag line that is wet or dirty can conduct electricity.

Working in the vicinity of radio frequency transmission towers/sources may cause a crane to become electrically "charged." Survey the work site and develop specific safety precautions and operating procedures, prior to commencing operations.

If contact is made with a power source - THINK -DON'T PANIC.

1. Warn everyone to stay away from the crane.
2. Attempt to free the crane by operating the crane functions.
3. Stay in the crane until the power source has been turned off.

You should, only as a last resort, attempt to leave the crane after contacting a power source.

If it is absolutely necessary to leave the cab, JUMP COMPLETELY CLEAR OF THE CRANE - DO NOT STEP OFF. Hop away with both feet together. DO NOT walk or run.

Following any contact with an energized electrical source, thoroughly inspect the wire rope and all points of contact with the crane.

Advise your supervisor of the incident, who should consult TACOM for advice and crane inspection instructions prior to resuming operations.

CRANE MISUSE

Do not strike anything with the boom. If the boom should contact an object; stop immediately. Inspect the boom. Do not use the crane if the boom is damaged.

Never push or pull something with the boom.

Do not add weight to counterweight to increase the crane's capacity.

Cranes are rated to handle freely suspended loads. Do not pull post, piling or submerged articles that may have a heavy accumulation of mud, silt or sand.

Never pull sideways with boom. Booms and swing systems are not designed to side pull and may be damaged from side loading. Booms are designed for lifting only freely suspended loads.

LIFT ONE LOAD AT A TIME. Do not lift two or more separately rigged loads at one time, even if loads are within the rated crane capacity.

PLANNING AND SET UP

1. Review the safety precautions in previous section.
2. Study the job site and select best location for the crane, where the:
 - a. Surface is solid,
 - b. Surface is level as possible,
 - c. Crane is as far away from electrical power sources, overhead power lines, etc., as possible,
 - d. Crane is sheltered from wind. (Be cautious if wind speed approaches 20 mph.).
3. Know weight of all loads before you attempt a lift. Ensure load to be lifted is within rated lifting capacity of the crane.

REMEMBER - all rigging equipment must be considered as part of load, **INCLUDING THE BOTTOM LIFT SLING.**

4. Measure load radius before making lifts and stay within approved lifting areas. Check your load chart.

Lifting capacities vary with working areas. Permissible working areas are posted in crane cab. When swinging from one working area to another, ensure load chart capacities are not exceeded. Know your crane!

When lifting loads, crane will lean toward boom and load will swing out, increasing load radius. Ensure load capacity chart is not exceeded when this happens.

Always keep the load as near to the crane and as close to the ground as possible.

5. Position crane and extend outrigger beams.
6. Place cribbing on ground and position floats under jack cylinders at four places. Use cribbing under outrigger floats to distribute weight over a greater area. Check frequently for settling.
7. Extend jack cylinders and latch cylinder ends to floats.

CAUTION

Unless lifting within On Rubber capacities, outrigger beams must be fully extended with jack cylinders extended to provide maximum leveling of crane. Remove all weight from tires before lifting on outriggers.

8. Use sight level bubble indicator to ensure crane is level.

NOTE

You can also use the load line to determine the levelness of the crane. It should always lie in the center of the boom. Check at two points 90 degrees apart.

WARNING

The importance of properly leveling a crane cannot be overstressed. A crane only slightly out-of-level can quickly encounter a tipping condition.

9. After crane has been set-up, make a dry run before making the first lift. Become familiar with all factors peculiar to job site. Know what moves to make **BEFORE** attaching first load.

USING YOUR LOAD CHART (REFER TO APPENDIX F.)

NOTE

One of the most important tools of every crane is the load chart found in the crane operator's cab. It contains information that must be thoroughly understood.

The load chart contains a 360 degree on-outriggers capacity chart and an on-rubber capacity chart. The capacity charts are divided into capacities limited by structural strength and capacities limited by stability. This is shown by the bold lines across the chart. Capacities above the line are limited by structural strength and capacities below the line are limited by crane stability.

The chart shows the radius of the load in a column at the left. The radius is the distance between the centerline of rotation of the crane and the center of gravity of the load. Various boom lengths are listed across the top, ranging from fully retracted to fully extended. The boom angle (in degrees) required for the given lift is shown in parentheses below the maximum total weight that can be lifted. Note that the boom lengths in between the increments shown should always be treated as if the boom was extended to the next longer length. For example, if the load chart has capacities for 50-foot and 55-foot boom lengths and the actual length of the boom in use is 52 feet, then the maximum capacity will be listed under the 55 foot boom length because the boom is beyond 50 feet in length.

Another important section of the load chart is the range diagram. The range diagram shows the tip height at each boom length, angle and radius. If you know the radius required for a specific lift and the tip height you can calculate the required boom length and angle needed for the lift. Check the capacity chart for the specific boom length and radius to find out if the crane is capable of performing the lift safely. If the boom length and angle are known, the radius can be determined from the range diagram.

A lifting area diagram is included as part of the load chart to describe over-the-side, over-the-rear, and over-the-front lifting areas. The lifting area diagram shows that the locations of the outrigger stabilizer cylinders in the fully extended position are used to mark the boundaries of the lifting areas.

The last major portion of the load chart is the section concerning notes on lifting capacities. Be sure to read all notes carefully so you understand what each one means. The weights of any load handling devices must be added to the weight of the load.

NOTE

The following is a typical example of a lifting problem and how to compute a lift. However, numbers used in the example may not coincide with the load chart in the crane cab.

The problem is to lift a container weighing 22.4 tons to a height of 46 feet at a radius of 27 feet. Determine whether or not the lift can be made safely. The range diagram shows the lift can be made using a boom length of 60 feet. A check of the on outrigger-360 degrees load chart at a 27 foot radius with a 60 foot boom length shows the crane has a lifting capacity of 48,000 pounds.

It appears from the listed capacity that 22.4 tons (44,800 pounds) can be lifted. But wait! The listed weight of all load handling devices such as slings, chains, spreader bar, bottom lift sling, or other rigging must be added to the load weight in order to obtain the actual weight of the load being lifted. For the purpose of this example we will assume that these load handling devices weigh 1500 pounds and must be added to the load weight (i.e., $44,800 + 1,500 = 46,300$ pounds). Therefore, the total load weight of 46,300 pounds can be lifted since the total weight of the load is less than the (48,000 pounds) maximum crane capacity in this configuration. Following the initial calculation, the load chart should be rechecked to assure that the crane is capable of making the lift. Also note the laden boom angle (found in parentheses under the weight capacity of the load chart) will be approximately 55.5 degrees.

DON'T FORGET

LOAD CHARTS REPRESENT THE ABSOLUTE MAXIMUM ALLOWABLE LOADS, WHICH ARE BASED ON EITHER TIPPING OR STRUCTURAL LIMITATIONS UNDER SPECIFIC CONDITIONS. KNOWING THE EXACT RADIUS OF OPERATION, BOOM LENGTH AND BOOM ANGLE SHOULD BE A PART OF YOUR ROUTINE PLANNING AND OPERATION. ACTUAL LOADS, INCLUDING NECESSARY ALLOWANCES, SHOULD BE KEPT BELOW THESE CAPACITY FIGURES.

WORKING AREAS MUST BE ADHERED TO WHEN DETERMINING ALLOWABLE LOAD FROM LOAD CHART(S).

IF THE CRANE IS NOT LEVEL, LOAD CAPACITIES ARE REDUCED WHEN LIFTING ON THE LOW SIDE. DON'T BE MISLED BY OPTICAL ILLUSIONS. USE YOUR BUBBLE LEVEL.

IF YOU FEEL THE CRANE IS BEGINNING TO TIP, LOWER THE LOAD WITH THE HOIST LINE AND RETRACT OR ELEVATE THE BOOM TO BRING THE LOAD IN. NEVER LOWER OR EXTEND THE BOOM, THIS WILL AGGRAVATE THE CONDITION.

WHEN USING THE HOIST AVOID SUDDEN STOPS. INCREASED LOADING WILL RESULT AND COULD CAUSE TIPPING OR A STRUCTURAL FAILURE.

EVEN IF A HYDRAULIC LINE BREAKS ON THE LIFT OR TELESCOPE CYLINDER(S), THE CRANE WILL STILL FUNCTION SUFFICIENTLY TO GET THE LOAD DOWN.

MAXIMUM LIFTING CAPABILITY OCCURS AT THE SHORTEST RADIUS, MINIMUM BOOM LENGTH AND HIGHEST BOOM ANGLE.

THIS CRANE IS NOT EQUIPPED WITH ANY WARNING OR INSULATING DEVICES THAT CAN PROTECT YOU FROM ELECTRICAL SHOCK. USE EXTREME CAUTION WHEN WORKING AROUND OR NEAR AN ENERGIZED POWER SOURCE OR POWER LINES.

ELECTRICITY CAN CAUSE SEVERE INJURY OR DEATH IF CONTACT OCCURS. ENSURE THAT ALL PERSONNEL ARE AWARE OF SAFETY PROCEDURES.

IF NOT REQUIRED TO PERFORM AN ON-RUBBER LIFT, THE BOTTOM LIFT SLING MUST BE REMOVED FROM ITS ON CRANE STOWAGE CRADLE FOR ALL ON RUBBER LIFTS.

NOTE

Carefully read and become familiar with all crane operating instructions before attempting a preload check and operating the crane under load.

OPERATE THE ENGINE AT OR NEAR FULL GOVERNED RPM DURING PERFORMANCE OF ALL CRANE FUNCTIONS.

PRELOAD CHECK

After the crane has been readied for service, an operational check of all crane functions (with no load applied) should be performed. Accomplish the Preload Check as follows:

1. Check all pin connections, bolts, latches, locks, braking and restricting devices and operational aids before operation. Perform a visual inspection and replace/tighten any damaged or loose devices prior to initiating any craning or traveling operations.
2. Check all braking and holding devices before operation. Perform an operational check of all brake (wheel and swing) and safety holding devices before starting any crane or traveling operations.
3. Check swing brake. Make certain the swing brake operates correctly. Unexpected free swinging of a boom can be dangerous.
Be sure everyone is clear of the crane and work area before swinging boom.
4. Raise, lower and swing the boom right and left a minimum of 45 degrees.
5. Telescope the boom in and out.
6. Raise and lower the cable a few times at various boom lengths. Ensure there is no kinking.

INITIAL LIFTING LOADS

1. Ensure that all slings, ties and hooks are correctly placed and secured before raising or lowering load.
2. Use tag lines, as appropriate, for positioning and restraining loads. Check load slings before lifting.

WARNING

Use only slings or other rigging devices rated for the job and use them properly. Never wrap the hoist cable around a load. Check all tackle, hardware, and slings before use. Refuse to use faulty equipment.

3. Be sure load is secured and attached to hook with rigging.
4. Be sure everyone is clear of crane and work area before making any lifts.
5. Always refer to the capacity on load chart in the cab BEFORE making any lift. Position hoist line to the radius required then lift load. Stay within approved work area for the load being lifted.
6. Be sure hoist line is vertical before starting the lift. Don't subject crane to side loadings.
7. Check hoist brake by raising the load a few inches and holding it there. Be sure hoist brake is working correctly before continuing lift.
8. Check for settling of outrigger floats. Watch bubble level and alignment of load line with boom.

CAUTION

The engine must be shut down before attempting to engage the hydraulic pump drive.

CAUTION

Always disengage the hydraulic pump for extended traveling, cold weather starting, or engine checks.

CAUTION

- Do not force the pump disconnect lever in an attempt to engage the pump drive.
9. Check that pump disconnect lever is in the appropriate position for the function being performed.
 - a. The hydraulic pumps and disconnect are mounted on the torque converter driver pads and operate anytime the engine is running and the pump disconnect lever is in the ENGAGE position.
 - b. The manual pump disconnect is actuated by a knobbed lever located on the deck between the turntable and front of the engine hood. It has two positions marked ENGAGE and DISENGAGE.
 - c. The disconnect can be used to prevent the three section hydraulic pump from being driven when the engine is running.

NOTE

It may be necessary to bump the starter to engage the pump drive.

PROGRAMING LMI FOR NORMAL OPERATION (RT875CCS)

NOTE

The complete LMI setup procedure must be performed each time that the system has been turned off for more than two (2) hours or if the crane configuration has been changed.

If the LMI system is shutdown during a short break (i.e., less than two (2) hours) in craning operations, all setup parameters will be stored. If the crane configuration has not changed, the LMI setup conditions can be confirmed.

AUTOMATIC LMI SETUP

WARNING

It is extremely important to enter the correct crane configuration when setting up the LMI system. The LMI setup procedure should be executed by personnel who are thoroughly familiar with the crane configuration and the setup procedure.

The LMI setup routine begins automatically if the system has been turned off for more than two (2) hours. The setup procedure can also be initiated manually by pressing the SEL key.

The LMI setup routine is an interactive process. The routine is performed by answering (keying in) responses to prompts by the LMI system. Function buttons F1, F2, F3, and F4 will be used.

The LMI setup routine can be cancelled at any time by pressing the SEL button.

The Load Moment Prewarning light and the Load Moment Limit light will come on during the LMI setup routine.

NOTE

If a configuration selected is not available, the LMI display will indicate an error code "E04". If this error appears, re-enter valid data.

The LMI setup procedure has been divided into four subparts:

1. Setting the hoist configuration.
2. Setting the outrigger configuration.
3. Setting the reeving configuration.
4. Confirming the setup values.

The following symbols will appear on the LMI console display screen during LMI setup.

1. Setting the hoist configuration. Select F1 for main hoist or F2 for aux(iliary) hoist.

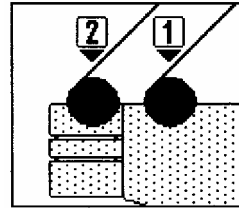

- 1** Main Hoist
- 2** Aux Hoist

2. Setting outrigger configuration. Select F1 for on rubber or F2 for on outriggers.

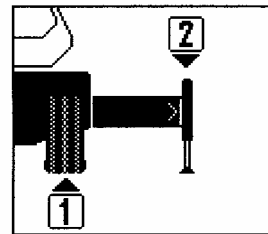

- 1** On Rubber
- 2** Outrigger position 100% (fully extended)

If on rubber was selected, the following will appear: Select F1 for static (stationary) or F2 for pick and carry (mobile).

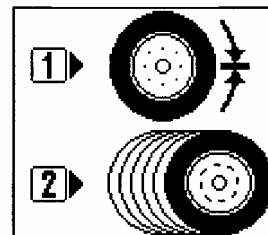

- 1** Static
- 2** Pick and Carry

3. Setting the reeving (parts of line). Select F2(+) or F3(-) to increase or decrease the number of lines. Then depress F4 (OK).

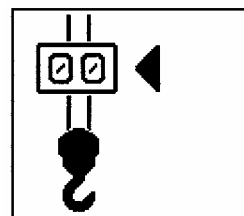

- +** Increase Reeving
- Decrease Reeving
- OK** Confirm Reeving

4. Confirm the LMI setup conditions. The operator will be prompted to confirm the LMI setup. To confirm and quit the setup, press F4 (OK). If all of the required inputs have been entered, all symbols will be black-filled.

CHANGING LMI SETTINGS DURING OPERATION

It may be necessary to change the LMI system settings during operation to reflect changes in the crane configuration.

1. Setting the reeving (parts of line).

If the number of lines change during operation, the LMI must be adjusted. This parameter can be changed as follows:

- a. Press the **SEL** (select) button.
- b. Depress the F2 button to call the routine for changing the reeving settings.
- c. Select the F2 (**+**) key or F3 (**-**) to increase or decrease the number of lines.
- d. Press F4 (**OK**) to quit the function and confirm the change.

2. Changing the hoist selection.

If hoisting operations change from the main to auxiliary hoist (or from auxiliary to main hoist), the LMI setup must be changed.

NOTE

Simultaneous use of both the main and auxiliary hoists is prohibited.

- a. Press **SEL** (select) button.
- b. Depress the F3 button to call the routine for changing the hoist selection setting.
- c. Depress F1 for the main hoist or F2 for the auxiliary hoist.
- d. Press F4 (**OK**) to quit the function and confirm the change.

SETTING LMI LIMITS

The LMI system can be programmed to limit the crane's operational range. Exceeding the programmed limits will trigger an audible and visual alarm. The following operating ranges can be set:

1. Boom Tip Height Limit Setting.

- a. Press **LIM** (limits) button.
- b. Press the F2 button to set the boom tip height limit.

- c. Press the F2 (**▲** - up) arrow. The display shows the boom tip height limit setting.
- d. Raise the boom to the desired upper limit.
- e. Press the F3 (**SET**) button to set or F1 (**DEL**) button to delete the boom tip height limit setting.
- f. Press F4 (**OK**) to quit the function and confirm the boom tip height limit setting.

2. Boom Angle Limit Setting.

- a. Press **LIM** (limits) button.
- b. Press the F3 button to set boom angle limit.
- c. Press the F3 button (**▲**) to set the upper boom angle limit.
- d. Raise the boom to the required upper limit. The display shows the upper boom angle setting.
- e. Press the F3 (**SET**) button to set or F1 (**DEL**) to delete the upper boom angle limit setting.
- f. Press F4 (**OK**) to quit the function and confirm the boom upper boom angle limit setting.
- g. Press the F3 button (**▼**) to set the lower boom angle limit.
- h. Lower the boom to the required lower limit. The display shows the lower boom angle setting.
- i. Press the F3 (**SET**) button to set or F1 (**DEL**) to delete the lower boom angle limit setting.
- j. Press F4 (**OK**) to quit the function and confirm the boom lower boom angle limit setting.

3. Boom Radius Limit.

- a. Press **LIM** (limits) button. Then press F1 to select boom radius limit function.
- b. Press the F2 (**◀**) button to select minimum boom radius.
- c. Position the boom to the required minimum boom radius limit. The display

shows a symbol representing the boom radius.

- d. Press the F3 **(SET)** button to set or F1 **(DEL)** button to delete the minimum boom radius limit setting.
- e. Press F4 **(OK)** to quit the function and confirm the minimum boom radius limit setting.
- f. Press the F1 **(▶)** button to select maximum boom radius.
- g. Position the boom to the required maximum boom radius limit. The display shows a symbol representing the boom radius.
- h. Press the F3 **(SET)** button to set or F1 **(DEL)** button to delete the maximum boom radius limit setting.
- i. Press F4 **(OK)** to quit the function and confirm the maximum boom radius limit setting.

DISPLAYING SYSTEM INFORMATION

The operator can display the current LMI system settings by depressing the **i** (information) button. The LMI console display will show a crane symbol indicating the adjusted LMI configuration settings. Depress the **i** (information) button again to display the current sensor output values. To end the function and to return to the normal system display, depress the **i** (information) button.

DISPLAYING TARE

1. Set up the crane at proper load radius for lift. Attach lifting device and tackle to hook block. Lifting device and tackle, excluding hook block must weigh at least 3,000 lbs (1,360 kg) for the Tare function to operate.
2. Depress **TARE** button. The LMI console display is set to zero (taring) and the control light illuminates.
3. Attach load to lifting device without changing the load radius and perform lift. The LMI console displays the net load.
Refer to Table 2-2 for exclusions.

DISPLAY CONTRAST CONTROL

The contrast on the LMI console display can be adjusted. The last contrast setting will be

stored in memory and therefore does not have to be readjusted each time the system is turned on.

NOTE

The LMI console display contrast setting can be changed during normal operation by pressing F3 to lighten or F2 to darken the display.

To change the contrast setting, press the **CTRL** button. Then press the F2 **(+)** or F3 **(-)** button to darken (+) or lighten (-) the display. Press the F4 **(OK)** button to store the contrast setting and exit the function.

Toggle between the daytime (normal) and nighttime (backlit) display by depressing the **CTRL** button then the F1 button. Press F4 **(OK)** to quit the function.

PROGRAMING LMI FOR NORMAL OPERATION (RT875CC)

1. Position Reeving Selector switch to correct number for parts of line being used.
2. Position ON OUTRIGGERS/ON RUBBER switch to ON OUTRIGGERS.
3. Position Data Selector switch to display desired information on Data Display.

NORMAL CRANING OPERATION

WARNING

Be sure everyone is clear of the crane and work area before making any lifts.

1. Keep everyone away from suspended loads. Allow no one to walk under a load.
2. Sound a warning before moving crane or when approaching personnel.
3. Always move toward the load and move slowly. Use a tagline to control the load.
4. Tag line personnel must guide the load from the ground.
5. When lifting loads, lift slowly and proceed with caution.

NOTE

Maintaining a steady tension may free load without shock loading crane

WARNING

Look before swinging your crane. Even though original set-up may have been checked, situations change.

6. Use caution when swinging loads.
7. Swinging rapidly can cause load to swing out and increase load radius. Swing the load slowly. Keep load lines vertical.
8. Never stand or work on or near the superstructure while crane is moving or swinging.

WARNING

Never leave crane with a load suspended. Should it become necessary to leave the crane, lower load to the ground and stop engine before leaving cab.

9. Stop hook block from swinging when unhooking a load.
10. If wire rope and load-handling device have been removed from a boom nose (main or auxiliary), ensure red by-pass flag (plug) is installed on appropriate anti-two block switch.

WARNING

The red by-pass flag (plug) should never be used to disable an anti-two block switch if there is wire rope reeved and a load-handling hook present.

CRANE FUNCTIONS

WARNING

The outriggers must be fully extended and set before any other operation of the crane is attempted, unless lifting on rubber. Refer to ensuring crane is stable, page 2-37.

SETTING THE OUTRIGGERS

1. Position outrigger floats 6.5 feet (2 m) directly out from each outrigger as follows:

WARNING

Each outrigger float weighs approximately 90 pounds (40.8 kg). Use two people to remove each float. Use caution when lifting.

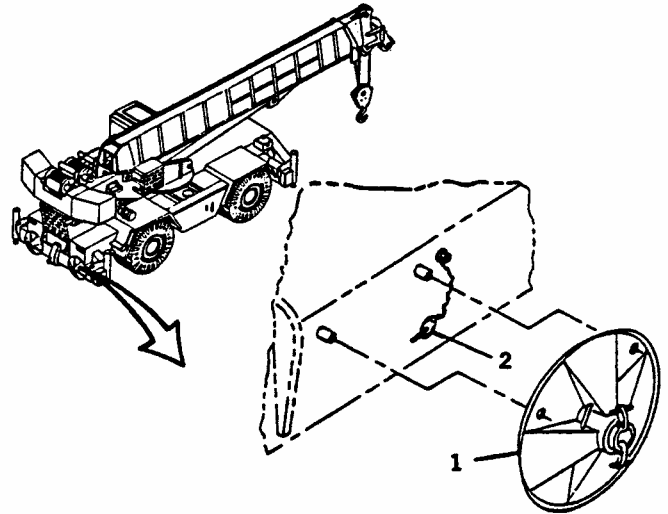

- a. Support weight of outrigger float (1).
- b. Remove quick disconnect pins (2) from mounting studs.
- c. Remove outrigger floats (1) from studs.

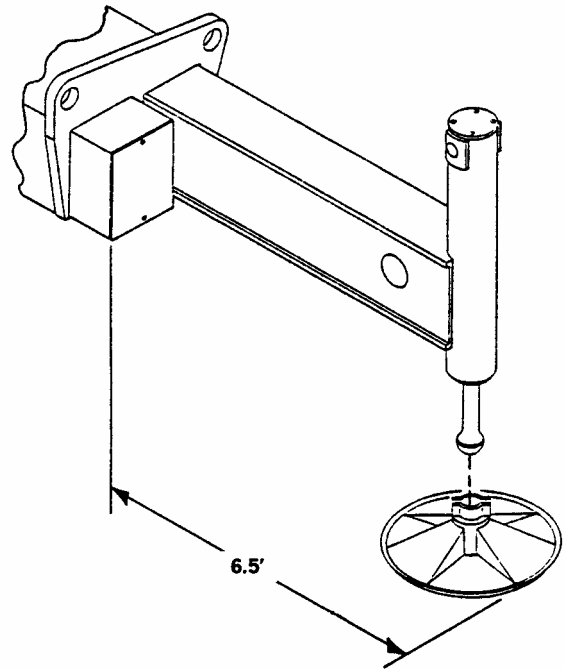

Positioning Outrigger Floats

2. Set EXTEND/RETRACT toggle switch to EXTEND position.
3. Set left or right EXTENSION toggle switch to extend either front or rear outrigger. The appropriate outrigger should begin to extend.

NOTE

More than one outrigger can be extended at one time. However, to ensure that all four outriggers are fully extended, each outrigger extension should be performed individually.

4. After all four outrigger beams are fully extended, use left or right STABILIZER toggle switch to extend front or rear stabilizer. (The EXTEND/RETRACT toggle switch should remain in the EXTEND position.)
5. Extend each stabilizer, positioning float as necessary, until locking levers of float engage the stabilizer cylinder.
6. With each stabilizer float firmly touching ground, use STABILIZER toggle switches to extend front stabilizers 3 to 4 inches (7.6 to 10.2 cm).
7. Then, use STABILIZER toggle switches to extend rear stabilizers 3 to 4 inches (7.6 to 10.2 cm).
8. Repeat the procedures in steps 6 and 7 until all wheels are clear of ground and crane is level, as indicated by the sight bubble level indicator located at right side control panel. If you suspect that the sight bubble level indicator is out of adjustment, verify and adjust it as follows.

- a. Locate crane on a firm level surface.
- b. Extend and set outriggers. Level crane, as indicated by the sight bubble level indicator, using the outriggers.
- c. Place a miracle pointer, carpenter level or similar device on a machined surface such as the turntable bearing or bearing mounting surfaces.
- d. Using outriggers, level crane as indicated on the device used in step c.

- e. Using mounting screws, adjust bubble level indicator to show level.

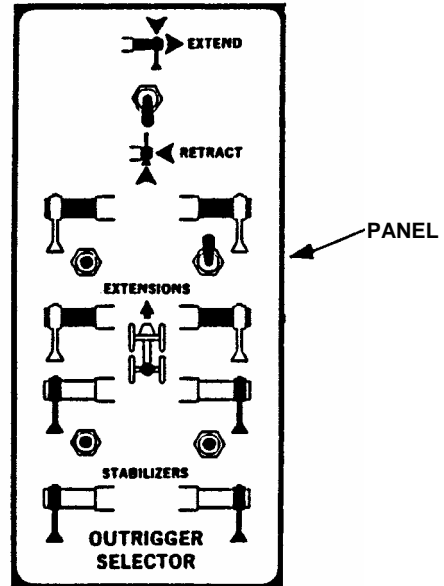

STOWING OUTRIGGERS

1. Set R (rear) STABILIZER toggle switches and position toggle switch to RETRACT until rear stabilizers retract several inches.
2. Set F (front) STABILIZER toggle switches and position toggle switch to RETRACT until front stabilizers retract several inches.
4. Repeat steps 1 and 2 until crane is resting on all 4 wheels and stabilizer floats are several inches off ground.

WARNING

Keep feet and hands clear of the floats when unlocking them from the stabilizer. Failure to follow this procedure could result in personnel injury.

4. Release locking levers and allow floats to drop to ground.
5. Continue to retract stabilizers until they are fully retracted.
6. Set appropriate EXTENSION toggle switch and position toggle switch to RETRACT each outrigger.

NOTE

More than one outrigger can be retracted at a time.

- 7. Stow outrigger floats on pins provided. Secure with lock pins.

SWINGING THE BOOM

WARNING

Before initiating any swing operations, make certain the area in the swing path of the hook and/or load, as well as the tail swing area, is clear of all objects and personnel.

WARNING

When swinging the load from over-the-front to over-the-side, check the load chart to make certain the applicable capacity is not exceeded. Traveling with any load over-the-side is unsafe.

WARNING

Always sound the horn to alert personnel in the area before swinging the boom.

WARNING

If the ELEVATE BOOM message appears on the LED alert display during swing, stop swing immediately and elevate the boom to clear the engine hood.

CAUTION

Ensure the swing lock is disengaged and the swing brake control is in the disengaged position before attempting the swing.

CAUTION

Never push or pull the swing control lever through neutral to the opposite direction to stop swing motion.

NOTE

Automatic rear axle oscillation lockout will activate when the boom swings more than five (5) degrees right or left of the crane centerline.

- 1. To swing boom, push the SWING control lever forward, away from you for RIGHT (clockwise) swing; and pull back, toward you for LEFT (counterclockwise) swing. Always operate control lever with a slow, even pressure.

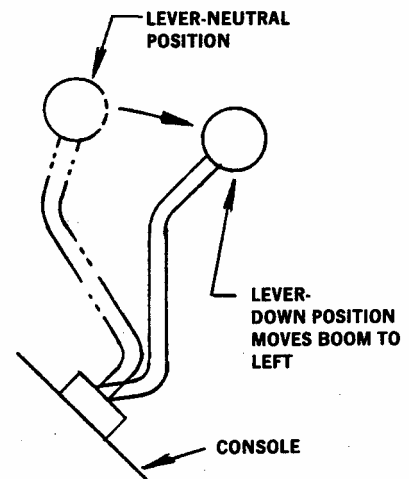
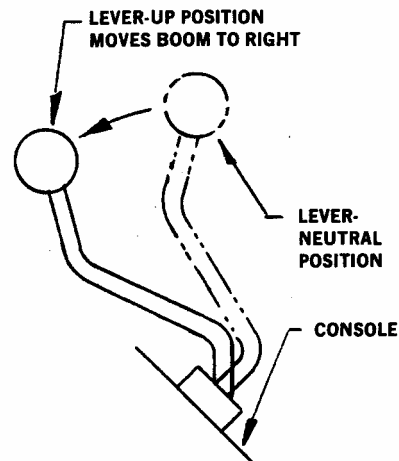

2. Depress swing brake foot pedal on left side of the cab under front console to stop boom swing.
3. When swinging has stopped, push the SWING BRAKE control to engage swing lock.

RAISING AND LOWERING BOOM

WARNING

Before raising the boom, ensure the area above and beneath the boom is clear of all objects and personnel.

1. To raise boom, pull BOOM lift control lever back toward you and hold until boom reaches desired angle.

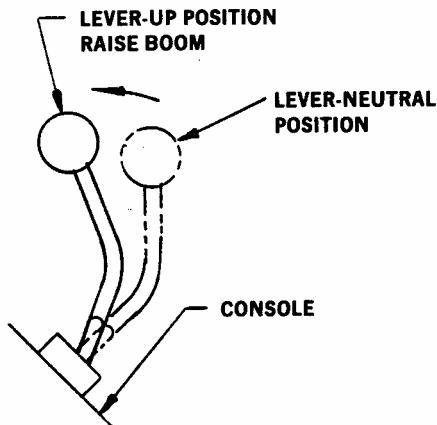

WARNING

Before lowering the boom, make certain the area beneath the boom is clear of all objects and personnel.

WARNING

When lowering the boom, let out hoist cable to prevent two-blocking the boom nose and the hook block.

CAUTION

The closer the load is carried to the boom nose, the more important it becomes to let out hoist cable as the boom is lowered.

2. To lower boom, push BOOM lift control lever forward, away from you, and hold until boom reaches desired angle.

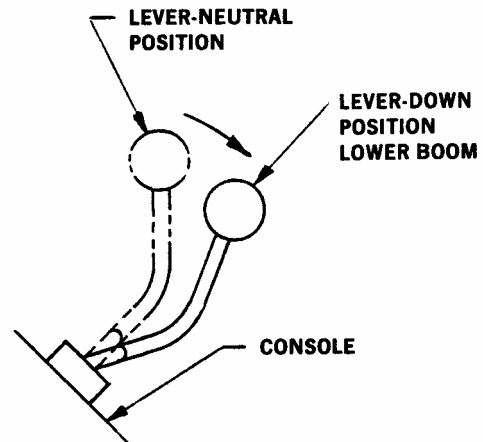

Boom Lift Control Pedal.

NOTE

The boom may also be raised or lowered using the boom lift control pedal.

1. Depress toe of pedal to lower boom angle.
2. Depress heel of pedal to raise boom.

TELESCOPING (EXTENDING) BOOM

WARNING

When extending the boom, let out hoist cable to prevent two-blocking the boom nose and hook block.

WARNING

Check the load chart for maximum load at given radius, boom angle, and length before extending boom with a load.

1. To extend boom, push TELE control lever forward away from you and hold until boom extends to desired length.

WARNING

When extending the boom, the load will raise unless the cable is let out.

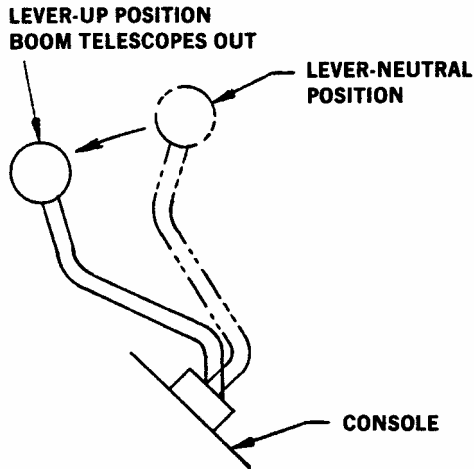

2. To retract boom, pull TELE control lever back, toward you and hold until boom retracts to desired length.

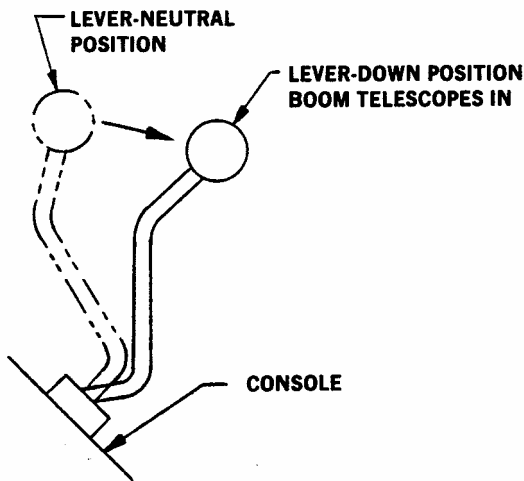

LOWERING AND RAISING HOIST CABLE

WARNING

Before lowering or raising the cable (load), ensure the area beneath the load is clear of all objects and personnel.

When paying out hoist cable, always leave a minimum of three wraps on the hoist drum for safety.

CAUTION

When starting or stopping the cable, do not jerk the control lever, jerking the lever causes the load to bounce, which could result in damage to the crane.

NOTE

When the load is stopped at the desired height, the hoist brakes will engage and hold the load as long as the control lever remains centered.

1. To lower hoist cable, push MAIN hoist or AUX hoist control lever forward, away from you, and hold until hook or load is lowered to desired height.

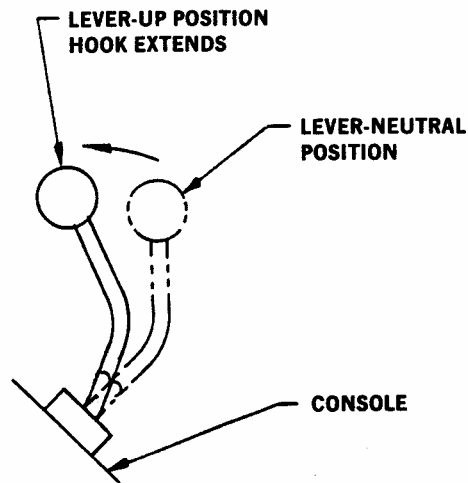

- To raise hoist cable pull MAIN hoist or AUX hoist control lever back, toward you, and hold until hook or load is raised to desired height.

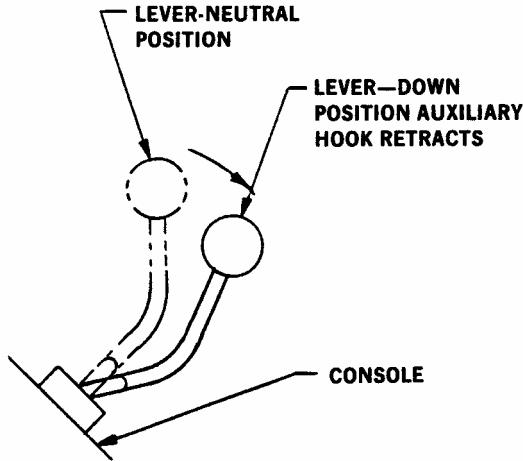

PARKING AND STOWING

WARNING

Never park the crane near holes or on rocky or extremely soft surfaces. This may cause the crane to overturn, resulting in injury to personnel and damage to the equipment. After crane is parked, complete following:

- If crane has been working on job site, retract and lower boom over-the-front (travel position).
- Set parking brake.

WARNING

Before leaving the crane, ensure swing lock and swing brake are both engaged.

- Chock the wheels if parking crane overnight or longer.

CAB HEATER

STARTING (RT875CCS)

- Pull the PULL FOR AIR FLOW Knob out to control air flow mix to windshield defroster and to heater vent below the seat.

NOTE

The cab heater igniter requires full system voltage to start. In order to ensure full system voltage, the crane's diesel engine must be running. After the cab heater starts, the engine can be shut down since the voltage supplied by the crane's batteries should be enough to run the heater fan and fuel pump.

- Start the diesel engine.
- Place START/OFF switch to START. Ensure POWER Green Indicator is lit. Heater fan will start after a short time delay.
- If FAULT Red Indicator comes on, heater failed to start.
- If heater failed to start, wait two minutes and depress PUSH TO RESET button. Verify that FAULT Red Indicator goes out.
- Repeat step 3 to start heater.
- Control air temperature by pulling (or pushing) the HEATER HI-LO control knob. Pull to increase air temperature.
- Shut down the diesel engine if applicable.

NOTE

The cab heater is factory set to operate on diesel fuel (DF-2) with the carburetor fuel adjustment knob installed so the pointed side of knob is pointing to 6 o'clock position. To switch from DF-2 to JP-8, turn carburetor fuel adjustment knob 1/8 turn clockwise. When switching back to DF-2, return fuel adjustment knob to its original position. See figure on page 2-56.

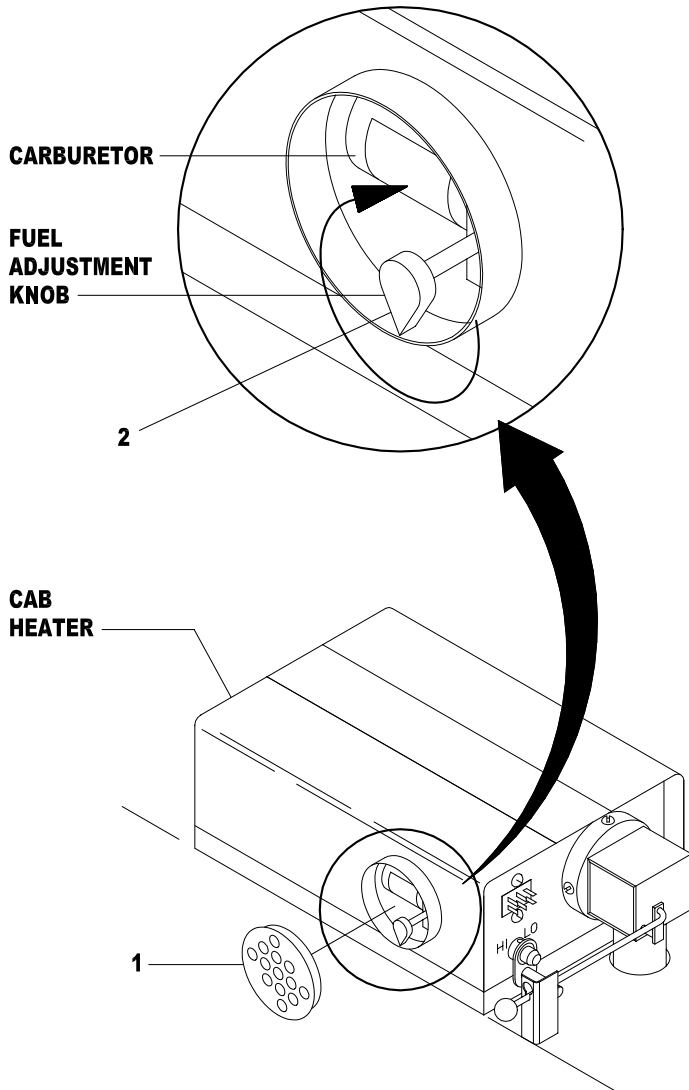

**Cab Heater Fuel Adjustment
(RT875CCS)**

STOPPING (RT875CCS)

1. Place START/OFF switch to OFF.

NOTE

The heater may not shut off immediately, since heater has a purge cycle. The blower will run until all fuel in the burner is consumed and heat exchanger cools sufficiently to open the flame switch. When this occurs, the blower motor will stop.

STARTING (RT875CC)

1. Switch AIR TEMP toggle switch to HI.
2. Pull HEATER ON/OFF switch to ON to begin the automatic starting sequence.
3. Set AIR TEMP toggle switch to HI (raises temperature) or LO (lowers temperature).

STOPPING (RT875CC)

1. Depress HEATER ON/OFF switch.

NOTE

The heater may not shut off immediately, since heater has a purge cycle. The blower will run until all fuel in the burner is consumed and heat exchanger cools sufficiently to open the flame switch. When this occurs, the blower motor will stop.

Section IV – OPERATION UNDER UNUSUAL CONDITIONS

INTRODUCTION

This section provides special procedures, safety precautions, etc. for weather conditions and modes of operation that are not ordinary. This section supplements the section "Operation Under Usual Conditions."

COLD WEATHER OPERATION

NOTE

Cold weather operation requires additional caution on the part of the operator.

1. Check operating procedures for cold weather starting.
2. Don't touch metal surfaces that could freeze you to them.
3. Clean crane, especially the boom, of all ice and snow.
4. Allow ample time for hydraulic oil to warm up.
5. During freezing weather, frequently check all air tanks for water.
6. Before lifting, ensure load is not frozen to ground or other surfaces.

WARNING

The use of aerosol spray or other types of starting fluids containing ether/volatiles can cause explosions or fire.

7. Use the cold weather starting aid provided for diesel engine. Refer to TM 5-3810-306-24P.

CAUTION

The drive line can be damaged when attempting to free a frozen crane.

8. In freezing weather, park crane in an area where it cannot become frozen to ground.

COLD WEATHER STARTING

The correct grade of oil for the prevailing temperature should be used in the crankcase to reduce hard cranking. Refer to LO 5-3810-306-12. Diesel fuel should have a pour point of 10°F (-12°C) less than the lowest expected temperature. In case of emergency, Diesel Fuel Inhibitor, NSN 6850-00-753- 5061 may be added to the fuel to bring the pour point down to the required temperature to prevent clogging of filters and small passages by wax crystals. The addition of kerosene is NOT recommended for general use. If low temperatures are ONLY expected at start-up, use the cold weather starting aid provided. Start crane as follows:

CAUTION

Do not engage or disengage hydraulic pump with the engine running. Otherwise, damage to the pump and drive could occur.

1. Disengage hydraulic pump at disconnect.
2. Position IGNITION switch to ON.
3. Depress and hold both ENGINE START and quick start pushbutton. After two seconds, release quick start pushbutton.
4. If engine does not start within 30 seconds, allow starter to cool for one or two minutes and repeat procedure.

WARNING

Avoid overloading the air box when using the quick start button. Do not attempt more than three consecutive starts without allowing the quick start fluid to dissipate. Otherwise, an overloading of the air box with highly explosive fluid could occur.

5. Allow engine and hydraulic oil to warm up to normal temperature before applying a load.

EMERGENCY STARTING

1. A NATO slave receptacle is located at the battery box for engine start from an external 24 VDC power source in the event the crane's batteries fail.

NOTE

The crane cannot be started by pushing or towing.

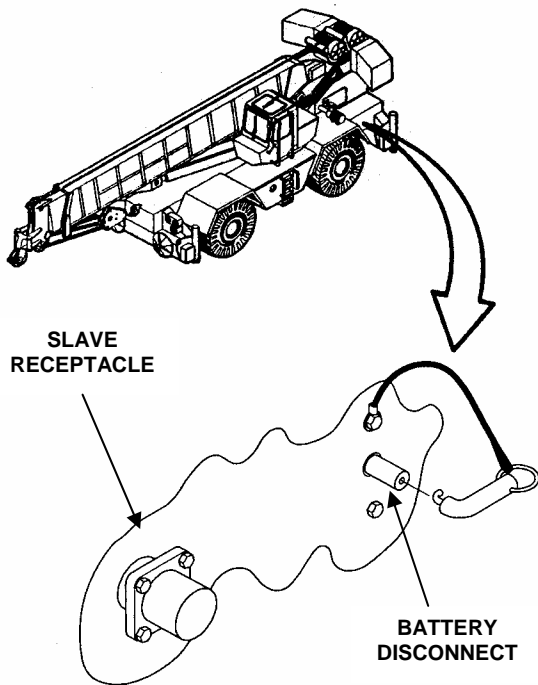

Slave Receptacle

PROGRAMMING THE LMI FOR LIFTING ON RUBBER (RT875CCS)

It will be necessary to revise the LMI system settings before performing craning operations on rubber (outriggers retracted). Follow the procedure for Programming the LMI for Normal Operation (page 2-46). When setting the LMI system up for on-rubber operations, the operator must select static (stationary) or pick and carry operation.

PROGRAMMING THE LMI FOR LIFTING ON RUBBER (RT875CC)

1. Position Reeving Selector switch to correct number for parts of line used.
2. Position the ON OUTRIGGERS/ON RUBBER switch to ON RUBBER.
3. Position STATIONARY/PICK & CARRY switch to desired position for type of on rubber lift.
4. Position Data Selector switch to display desired information on Data Display.

LIFTING ON RUBBER

1. When lifting a load on rubber (i.e. without extending outriggers), review all safety precautions for operating on rubber.
2. Study job site and determine best location for crane.
3. Get weight of load, measure load radius and check On-Rubber Capacity Chart (Refer to Appendix F) for boom length and angle.
4. Position crane on level surface.
5. Dry Run - Follow Preload Check procedure.
6. Rig load and attach to hook.
7. Be sure everyone is clear of the crane and the work area.
8. Raise load a few inches and hold it there. Check that hoist brake is working correctly. Check for settling of tires. Watch bubble level indicator and alignment of the load line with boom. If there is any sign of instability, put the load down and move crane to a more level surface.

WARNING

If not required for an on-rubber lift, the bottom lift sling must be removed from

its on crane stowage cradle for ALL on rubber lifts.

PICK AND CARRY OPERATIONS

WARNING

Exercise extreme caution when picking and carrying a load.

1. When performing pick and carry operations or operating on sloping ground, carry loads much less than capacity. Keep load low and uphill from the crane. Swing load only to keep the load uphill, and always place loads on high side.
2. When traveling with a load, boom should be carried in line with the direction of motion.

EMERGENCY BOOM OPERATING PROCEDURES

Although improbable, the boom lift cylinders hydraulic equalizer line could fail. If this occurs, there are devices that allow continued crane operation. All crane functions remain operable until the hydraulic oil in the reservoir is depleted. The most important thing is to get the boom in a safe position so that repairs can be made. The following procedures are recommended for getting the boom to a safe position should the equalizer line fail.

1. Don't panic. Remain in cab. All functions can be accomplished from the cab.
2. Maintain engine at normal operating speed.
3. Maintain desired boom angle by pulling back on boom control lever, as necessary. With oil leaking from the hydraulic system, boom angle will drop if you do not retract.
4. While maintaining boom at this angle: activate swing; retract boom; and operate hoist(s) as necessary until load is safely lowered to ground.
5. If over-the-side, retract as much boom as is possible and then lower boom. If over-the-front, it will not be necessary to retract the boom. Remember, boom cannot be lowered to minimum elevation over-the-rear, as boom would hit engine hood.

EMERGENCY STOWAGE PROCEDURE (RT875CCS)

In the event of a hydraulic system failure (pumps, diesel engine, etc.), it may be necessary to lower a suspended load, lower and retract the boom, swing the boom over the front, raise and retract the outriggers, and straighten the wheels in order to tow the crane to a maintenance area. To return the crane to the travel mode, proceed as follows:

WARNING

Failure to follow procedures could result in death or serious injury.

EMERGENCY STOWAGE STARTUP

1. Stop the diesel engine, apply the parking brake, place transmission in neutral, and disengage the main hydraulic pump drive.
2. Verify that the IGNITION ON/OFF switch is OFF and that the main hydraulic pump drive is disengaged.
3. Open the cover on Emergency Stowage control panel and verify that PUMP FUNCTION ON/OFF switch (1) is OFF and that the CRANE/FRONT STEER switch (2) is in CRANE position.
4. Verify that battery disconnect switch is on (key inserted and turned clockwise).

NOTE

If the crane's battery power fails while performing the following procedures, place the PUMP FUNCTION ON/OFF switch (1) to OFF and connect an auxiliary vehicle having a compatible NATO slave intervehicular cable and a 24 VDC electrical system to the crane's NATO slave receptacle located on the left side at the battery box. Then place the PUMP FUNCTION ON/OFF switch (1) to ON and with the diesel engine running on the auxiliary vehicle, continue the emergency stowage procedure.

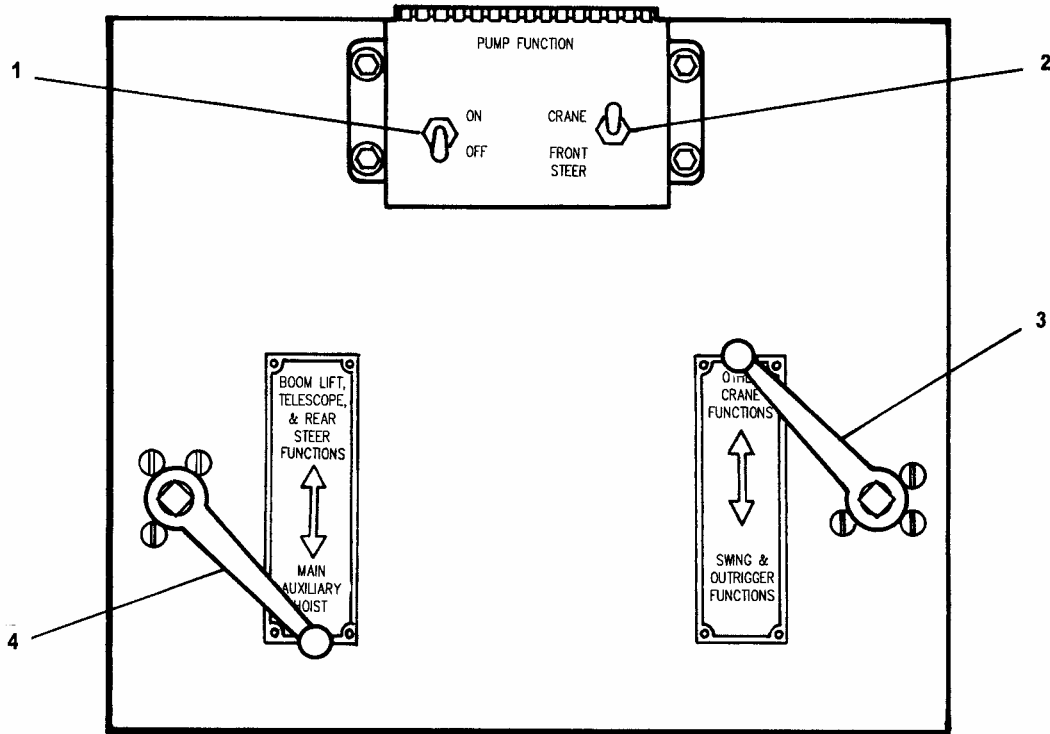

Emergency Stowage Control Panel (RT875CCS)

NOTES

The LMI may not be operational, depending on the type of failure experienced.

Operate only one crane function at a time.

The swing and outrigger functions are available when the right-hand control handle (3) is in the SWING & OUTRIGGER FUNCTIONS position. The left-hand control handle (4) can be in either position.

5. Place the IGNITION ON/OFF switch to ON.

NOTE

To conserve battery electrical power, place the PUMP FUNCTION ON/OFF switch (1) in OFF position, when not operating an emergency stowage function.

6. Place PUMP FUNCTION ON/OFF switch (1) to ON.

LOWER A SUSPENDED LOAD

WARNING

Do not extend or lower the boom when lowering a suspended load to the ground.

NOTE

It may be necessary to bypass the LMI system when performing certain functions.

1. Place right-hand control handle (3) to OTHER CRANE FUNCTIONS.

NOTE

It will be necessary to shift the left-hand control handle (4) between the function(s) being operated, i.e., hoists or boom lift/telescope.

2. If a load is suspended in the air, alternately use the swing, telescope, and/or hoist functions as applicable, to lower the load on the hook block/bottom lift sling to the ground and detach. Be sure to disengage the positive swing lock and SWING BRAKE before rotating the superstructure.

STOW THE HOOK BLOCK, OVERHAUL BALL, AND BOOM

1. Place right-hand control handle (3) to OTHER CRANE FUNCTIONS.
2. Alternately place left-hand control handle (4) to BOOM LIFT, TELESCOPE & REAR STEER and MAIN AUXILIARY HOISTS positions. Use the TELESCOPE and MAIN HOIST control levers to retract the boom while raising the hook block to keep it clear of the ground or adjacent to the crane structure.
3. Place right-hand control handle (3) to SWING & OUTRIGGER FUNCTIONS.
4. If set, disengage positive swing lock and pull out the SWING BRAKE ON/OFF control knob. Then use the SWING control lever to rotate the superstructure until the boom is over the front of the carrier.
5. Place right-hand control handle (3) to OTHER CRANE FUNCTIONS.
6. Alternately place left-hand control handle (4) to the BOOM LIFT, TELESCOPE & REAR STEER FUNCTIONS and MAIN AUXILIARY HOISTS and use the MAIN (hoist) control lever to position the hook block directly over the tiedown loop. Secure the hook block to the tiedown loop.
6. If necessary, use the AUX (hoist) control lever to lower the overhaul ball. Remove and stow the overhaul ball.
7. Alternately place left-hand control handle (4) to BOOM LIFT, TELESCOPE & REAR STEER FUNCTIONS position. Then use BOOM control lever to lower the boom to horizontal. Keep hoist cables taut while lowering boom.
8. Engage swing locks.

RETRACT OUTRIGGERS

1. Place right-hand control handle (3) to SWING & OUTRIGGER FUNCTIONS.
2. Fully retract the outrigger stabilizers using the OUTRIGGER SELECTOR switches. Then retract the outrigger extension cylinders.

CENTER REAR WHEELS

1. Place right-hand control handle (3) to OTHER CRANE FUNCTIONS.
2. Place left-hand control handle (4) to BOOM LIFT, TELESCOPE, & REAR STEER FUNCTIONS.
3. Use (rear) STEER control lever to straighten the rear wheels.

CENTER FRONT WHEELS

1. Place CRANE/FRONT STEER switch (2) to FRONT STEER.
2. Use the steering wheel to center the front wheels.

RESTORE CRANE TO TRAVEL MODE

1. Place the IGNITION ON/OFF switch to OFF and place the PUMP FUNCTION ON/OFF switch (1) to OFF. Ensure that CRANE/FRONT STEER switch (2) is in CRANE position. Close the cover on the Emergency Stowage control panel.
2. Remove and stow outrigger floats.
3. If the crane cannot be driven, place battery disconnect in the off position (key removed). Tow or recover the crane as described in this manual.

EMERGENCY LOAD LOWERING PROCEDURE (RT875CC)

In the event of a hydraulic system failure (pumps, diesel engines, etc.), it will be necessary to lower a suspended load, retract the boom, swing the boom over the front and retract the outriggers in order to tow the crane to a maintenance area. To return the crane to the travel mode from; elevated and extended boom; over-the-side; with suspended load and

outriggers extended and set; proceed as follows:

NOTE

A hand pump is permanently installed behind the sheet metal, on the right hand side of the crane, forward of the hydraulic reservoir. Refer to the figure titled - Hand Pump Operation, provided for this procedure.

1. Install pump handle and hoses.
 - a. Remove pump handle and three (3) hoses (one each at 12-feet, 18-feet and 38-feet long) from tool box.
 - b. Install pump handle.
 - c. Connect 38-foot long hose (with couplings on both ends) to quick coupler on hand pump. This is the hand pump pressure hose.
2. Lower load.
 - a. Check to make sure that load can be lowered without contacting extended outrigger or crane carrier. If necessary, retract boom, (step 3) or rotate boom (step 5) enough to assure safe load lowering.
 - b. Loop hand pump pressure hose out from under hydraulic tank cover and carry loose end up onto superstructure to hoist (main or auxiliary as applicable).
 - c. Uncouple hoist brake release quick coupler of hoist supporting load.
 - d. Install loose end of hand pump pressure hose to half of quick coupler leading to hoist brake.
 - e. Pump hand pump lever. By pumping the handle, hydraulic pressure is applied to the hoist brake, releasing the brake and slowly lowering the load.
 - f. Disconnect hand pump pressure line and reconnect hoist brake release quick coupler after load has been lowered to ground.
3. Retract boom.

NOTE

Retracting the boom is a two-person operation.

- a. Carry loose end of hand pump pressure line onto superstructure.
 - b. Open cover on control valve compartment (behind cab).
 - c. Locate tele-rear steer-lift valve bank (center of control valve compartment).
 - d. Remove dust cover on male coupler installed on inlet section of valve bank. Connect hand pump pressure hose at coupler.
 - e. Instruct operator in cab to pull back on TELE control lever. Hold lever in this position.
 - f. Pump hand pump lever. By pumping the handle, hydraulic pressure is applied to the telescope cylinder control valve causing the boom telescope section to slowly retract.
 - g. Return TELE control lever to neutral position after boom has been retracted.
 - h. Disconnect hand pump pressure hose at control valve bank and install dust cap on male coupling.
4. Lower boom.

NOTE

If transporting crane, do not lower boom beyond horizontal.

- a. Carry bleed-down hose (12-foot long hose with only one coupling) onto superstructure.
- b. Ensure that lift bleed-down valve is in OFF position.
- c. Remove dust cover on male coupler on bleed-down valve.
- d. Connect female coupler on bleed-down hose to male coupler on valve.

- e. Remove breather/fill cap on hydraulic tank by turning it one-quarter turn counterclockwise.

CAUTION

When inserting bleed-down hose in the hydraulic reservoir, use care to avoid damaging the inlet strainer.

- f. Insert cut off end of bleed-down hose in the hydraulic reservoir opening.
 - g. Slowly open bleed-down valve to lower boom.
 - h. Close bleed-down valve when boom has lowered to desired height.
 - i. Disconnect bleed-down hose at bleed-down valve. Reinstall dust cap on male coupler.
 - j. Carefully remove bleed-down hose from hydraulic reservoir opening.
 - k. Replace breather/fill cap on hydraulic reservoir.
5. Rotate boom over-the-front.

NOTE

This procedure requires a towing vehicle and pull cable or chain of sufficient capacity and length to pull the superstructure around to the front with the swing brake released.

- a. Connect 38-foot long pump pressure hose to hand pump.
- b. Loop free end of hand pump pressure hose out from under hydraulic tank cover and carry free end of hose up onto crane superstructure.
- c. Remove dust cap on male quick coupler located on swing brake.
- d. Connect free end of hand pump pressure line to swing brake quick coupler.
- e. Attach pull chain or cable to counterweight sling lug.

CAUTION

Do not pull on boom. Applying a side load to boom could cause irreparable damage.

- f. Unlock positive swing lock.
 - g. Pump hand pump to release swing brake while applying steady pull with towing vehicle. Pull boom around until boom is centered over the front.
 - h. Engage positive swing lock.
6. Retract outrigger.

NOTE

Each outrigger jack and beam must be retracted/raised separately.

- a. Disconnect 38-foot long hose at hand pump (if installed).
- b. Connect 18-foot long hose (shorter hose with two connectors) to quick coupler on hand pump. This is hand pump pressure hose.
- c. Connect female end of hand pump pressure hose to male fitting located on inside surface of left hand carrier side rail.
- d. Close shut-off valve located near connection made in step c. This valve must be closed to manually retract outriggers.
- e. Locate front outrigger valve stack (back side of front outrigger box). Locate rear outrigger valve stack (inside surface of left hand carrier side rail just forward of rear outrigger box).
- f. Locate four (4) quick couplers (four on each outrigger valve stack). The two inside couplers retract jack cylinders. The two outside couplers retract extension cylinders (beams).
- g. Connect 38-foot long hose (with couplers on each end) to quick coupling on back of hydraulic reservoir. This is the hydraulic return line.

- h. Select first jack cylinder to be retracted.
 - i. Connect free end of hydraulic return line to appropriate quick coupler on front (or rear) outrigger valve stack. Jack cylinders are retracted using the two inside quick couplers on each valve stack.
 - j. Pump hand pump until jack cylinder is completely retracted.
 - k. Repeat steps i and j for each of the other three outrigger jack cylinders.
 - l. Select first extension cylinder (beam) to be retracted.
 - m. Connect free end of hydraulic return line to appropriate quick coupler on front (or rear) outrigger valve stack. Extension cylinders are retracted using the two outside quick couplers on each valve stack.
 - n. Pump hand pump until extension cylinder (beam) is completely retracted.
 - o. Repeat steps m and n for each of the other three outrigger extension cylinders.
 - p. Disconnect all hoses and reinstall dust caps where provided.
 - q. Open shut-off valve that was closed in step d.
7. Stow equipment.
- a. Disconnect hand pump pressure line. Cap all quick disconnect couplings.
 - b. Coil three (3) hoses and stow them in tool box.
 - c. Remove pump handle and stow it in tool box.
8. When towing crane, refer to shipping plate posted on crane and use towing lugs provided.

TOWING

WARNING

On open ground, tow or pull only on the pintle hook or tow lugs.

CAUTION

Should the crane become mired down, use a tow truck or tractor to free the vehicle. Severe damage to the transmission or axles may occur if the operator attempts to free the crane unassisted.

Two tow lugs are located on each end of 1 the crane. When using these lugs, always tow using a towbar conforming to MS50048, heavy duty capacity.

CAUTION

Contact Organizational Maintenance to disconnect the front driveline before towing the crane. Ensure the drive axle selector is at 2WD-HI, to lockout the rear drive line.

NOTE

Maximum towing speed with the drive shafts installed is 2 mph (3 kph) for a maximum of 6 miles (10 km).
Maximum towing speed with both drive shafts removed is 20 mph (32 kph).

1. With boom over the front and lowered, engage positive swing lock. Pull SWING BRAKE switch to set swing brake.
2. Connect tow bar of tow vehicle to towing lugs on crane.
3. Connect safety chain from towing vehicle to crane tiedown lugs.
4. Ensure crane parking brake is set. Also ensure parking brake is set on towing vehicle.
5. Ensure transmission shift lever is in N (neutral) position.
6. If engaged, disengage main hydraulic pump via the pump disconnect lever.
7. Straighten both front and rear wheels.
8. If crane is to be towed for more than 6 miles (10 km) and/or towing speed will exceed 2 mph (3 kph), contact Organizational maintenance to remove front drive line.

9. Ensure drive axle selector is positioned at 2WD-HI.
10. If towing vehicle has a 140-psi (827 kPa) maximum auxiliary air supply, connect air hose to AUX AIR IN connection at rear of crane. Charge crane air system using

auxiliary air supply.

11. Release crane parking brake by depressing PARK BRAKE knob. If no auxiliary air supply is available, cage the rear axle air brake chamber springs to release the parking brake.

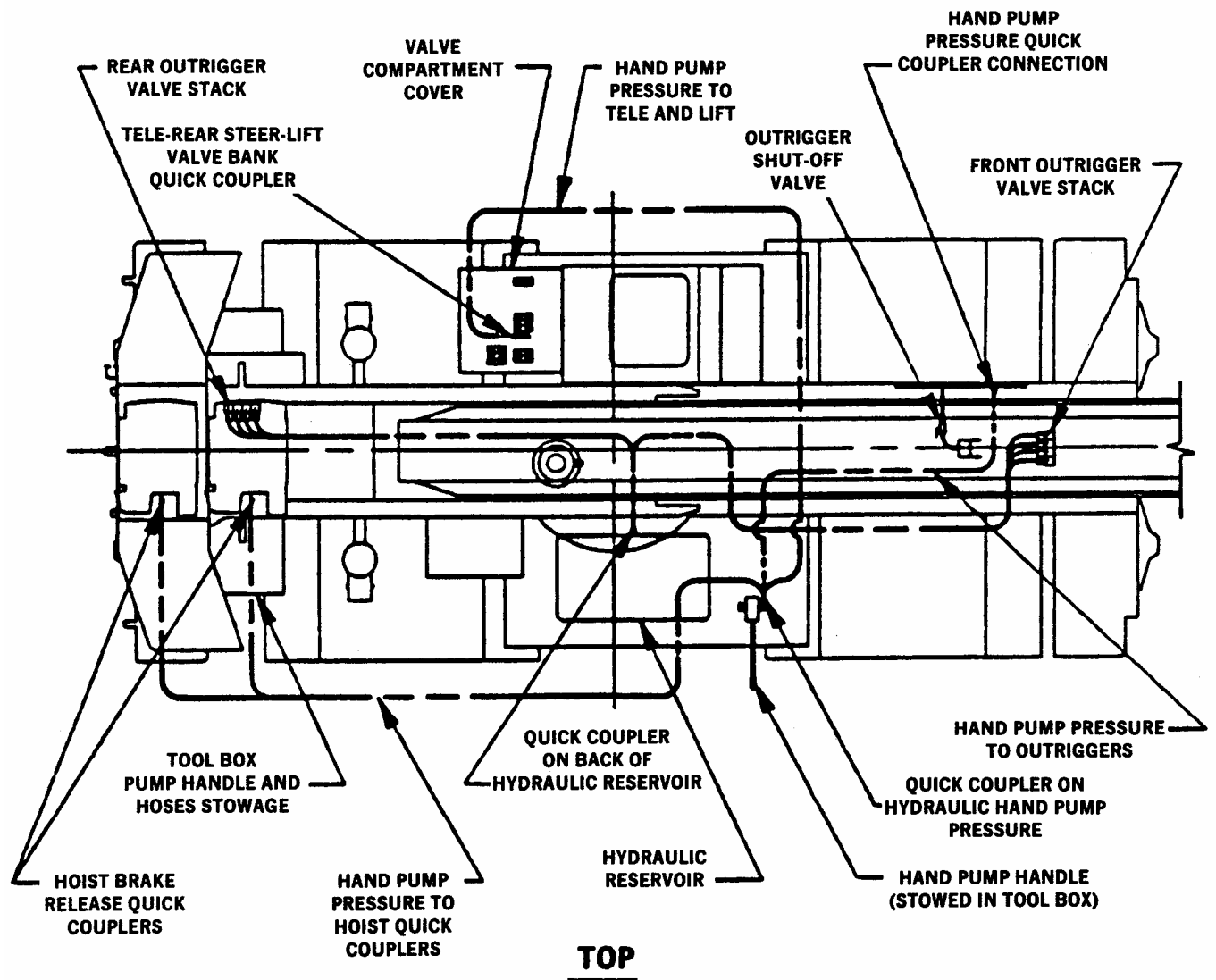

Hand Pump Operation for Emergency Load Lowering (RT875CC)

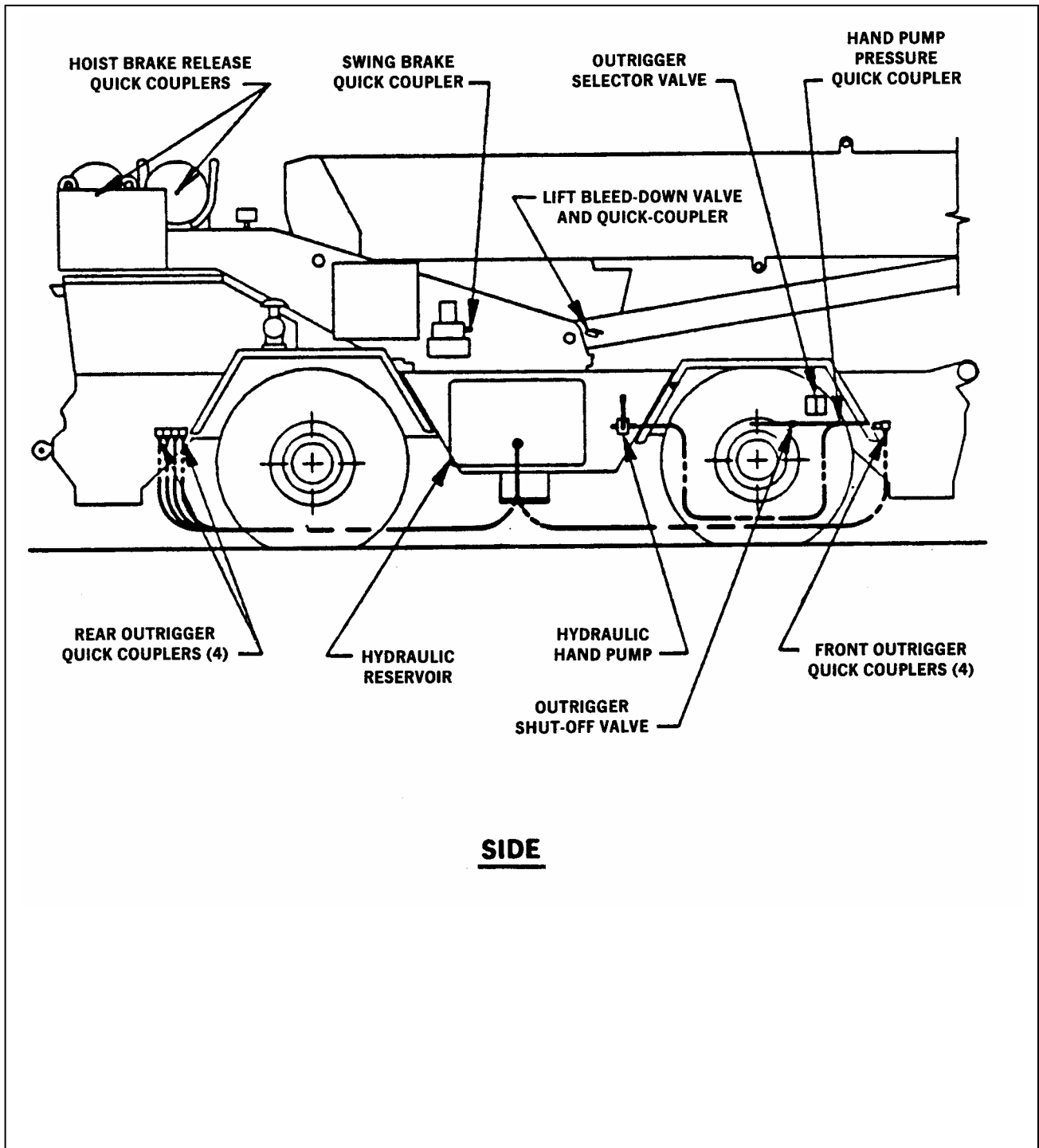

Hand Pump Operation for Emergency Load Lowering (RT875CC)

CHAPTER 3 – MAINTENANCE INSTRUCTIONS

Section I – LUBRICATION

LUBRICATION ORDER

Lubricate the crane in accordance with the Lubrication Order, LO 5-3810-306-12.

Section II - TROUBLESHOOTING PROCEDURES

Malfunction	SYMPTOM INDEX	Troubleshooting Procedures Page
ENGINE		
Engine will not crank or cranks slowly		3-3
Engine hard to start or will not start – exhaust smoke present		3-3
Engine cranks, but will not start - no smoke from exhaust		3-4
Engine starts but will not keep running		3-4
Engine will not shut off		3-4
Rough idle, warm engine		3-5
Engine surges at idle		3-5
Low lubricating oil pressure		3-5
Lubricating oil pressure too high		3-5
Lube oil loss		3-6
Contaminated engine oil		3-6
Exhaust smoke excessive under load		3-6
Engine will not reach rated speed when loaded		3-6
Low power		3-7
Engine misfiring		3-7
Fuel knock		3-7
Excessive fuel consumption		3-7
Excessive vibration		3-8
Excessive engine noises		3-8
Fuel or oil leaking from exhaust manifold		3-8
COOLING SYSTEM		
Coolant temperature above normal		3-8
Coolant loss		3-9
Coolant temperature below normal		3-9
Contaminated coolant		3-9
ELECTRICAL SYSTEM		
Alternator not charging or insufficient charging		3-10

Malfunction	Troubleshooting Procedures Page
TRANSMISSION	
Crane will not move or moves erratically (transmission failure)	3-10
Transmission oil temperature above normal	3-10
BRAKES	
Brakes are poor or do not apply.....	3-11
HYDRAULIC SYSTEM	
All crane functions inoperable (No two-block condition) (RT875CCS).	3-11
Hard to steer left and right	3-11
Rear steering inoperative.....	3-11
Slow or erratic operation of outrigger cylinders.....	3-11
Jack cylinder retracts under load	3-11
Jack cylinder extends while machine is traveling.....	3-12
Outrigger system will not operate	3-12
Outrigger system activates, but selected outrigger will not retract or extend and lower as desired	3-12
Outriggers will not set	3-12
Boom raises or lowers erratically.....	3-12
Boom raises or lowers slowly.....	3-13
Boom will not raise or lower	3-13
Erratic operation of telescoping cylinder.....	3-13
Telescope cylinder will not extend or retract.....	3-14
Hoist will not raise load	3-14
Hoist will not lower load	3-14
Slow or erratic hoist operation	3-14
Boom swing operations erratic in either direction	3-15
Swing brake system will not operate	3-15
CAB HEATER	
Cab heater stops or does not start	3-15
Cab heater fails to start – motor does not run (RT875CCS)	3-15
Cab heater fails to start – motor runs (RT875CCS)	3-16
Cab heater exhausts black smoke	3-16

NOTE

The error codes listed below are able to be corrected by a crane operator. If an error code appears on the LMI console that is not listed below, it indicates a fault in the LMI system, contact Organizational Maintenance.

LOAD MOMENT INDICATOR

Error Code E01 on LMI MOMENT DISPLAY.....	3-16
Error Code E02 on LMI MOMENT DISPLAY.....	3-16
Error Code E04 on LMI MOMENT DISPLAY.....	3-17
Error Code E05 on LMI LOAD DISPLAY	3-17
Error Code E80 on LMI MOMENT DISPLAY.....	3-17
Error Code EEE on LMI MOMENT DISPLAY	3-17
Error Code E89 on LMI LOAD DISPLAY (RT875CCS)	3-17

TROUBLESHOOTING TABLE

INTRODUCTION

- a. The table lists the common malfunctions which you may find during the operation or maintenance of the Container Crane or its components. You should perform the tests/ inspections and corrective actions in the order listed.
- b. This manual cannot list all malfunctions that may occur, nor all test or inspections and corrective actions. If a malfunction is not listed or is not corrected by listed corrective actions, notify your supervisor.

WARNING

Before starting any troubleshooting procedures please wear the proper eye protection in order to insure personal safety.

Table 3-1. Operator Troubleshooting

MALFUNCTION
TEST OR INSPECTION
CORRECTIVE ACTION
<u>1. ENGINE WILL NOT CRANK OR CRANKS SLOWLY</u>
<ul style="list-style-type: none"> Step 1. Hydraulic pump engaged. <ul style="list-style-type: none"> a. Check position of hydraulic pump disconnect lever. If pump disengaged, do step 2. b. Disengage hydraulic pump. Step 2. Starting circuit connections loose or corroded. <ul style="list-style-type: none"> a. Inspect connections at starting motor. If tight and corrosion free, do step 3. b. Clean and tighten connections. Step 3. Battery charge low. <ul style="list-style-type: none"> a. Contact Organizational Maintenance to charge/service batteries.
<u>2. ENGINE HARD TO START OR WILL NOT START - EXHAUST SMOKE PRESENT</u>
<ul style="list-style-type: none"> Step 1. Starting aid needed for cold weather. <ul style="list-style-type: none"> a. Use cold weather starting aid. If engine does not start do step 2. Step 2. Intake air system restricted. <ul style="list-style-type: none"> a. Inspect air cleaner inlet hood. If ok, do step 3. b. Contact Organizational Maintenance to remove intake hood and air filter element. Replace air filter element and clean intake hood. Step 3. Fuel contaminated. <ul style="list-style-type: none"> a. Check fuel for contamination. If fuel ok, do step 4. Step 4. Contact Organizational Maintenance.

Table 3-1. Operator Troubleshooting - Continued

MALFUNCTION
TEST OR INSPECTION
CORRECTIVE ACTION

3. ENGINE CRANKS, BUT WILL NOT START - NO SMOKE FROM EXHAUST

- Step 1. No fuel in tank.
 - a. Check fuel level in tank. If ok, do step 2.
 - b. Service fuel tank.
 - Step 2. Fuel-water separator plugged with water.
 - a. Drain fuel-water separator.
 - Step 3. Contact Organizational Maintenance.
-

4. ENGINE STARTS BUT WILL NOT KEEP RUNNING

- Step 1. Engine starting with hydraulic pump engaged.
 - a. Check position of hydraulic pump disconnect lever. If pump disengaged, do step 2.
 - b. Disengage hydraulic pump.
 - Step 2. Fuel waxing due to cold weather.
 - a. Drain fuel-water separator. If ok do step 3.
 - b. Contact Organizational Maintenance to drain fuel tank and service with cold weather fuel grade.
 - Step 3. Fuel contaminated
 - a. Check fuel for contamination. If fuel ok, do step 4.
 - Step 4. Contact Organizational Maintenance
-

5. ENGINE WILL NOT SHUT OFF

CAUTION

Do not use the BATTERY DISCONNECT switch as an emergency stop switch. Placing the BATTERY DISCONNECT switch in the off position will not shut down the diesel engine and could result in damage to the alternator. (RT875CCS)

- Step 1. Fuel system malfunction.
 - a. Extend and lower outriggers.
 - b. Open right-side engine access door and manually move fuel shutoff lever clockwise to off position and hold until the diesel engine stops running or close fuel shutoff valve at fuel sediment bowl (RT875CC) or at the fuel warmer/water separator (RT875CCS).
 - c. Contact Organizational Maintenance.
-

Table 3-1. Operator Troubleshooting - Continued

MALFUNCTION	TEST OR INSPECTION	CORRECTIVE ACTION
<u>6. ROUGH IDLE, WARM ENGINE</u>		
	Step 1. Intake air system restricted.	<ul style="list-style-type: none"> a. Inspect air cleaner inlet hood. If ok, do step 2. b. Contact Organizational Maintenance to remove intake hood and air filter element. Replace air filter element and clean intake hood.
	Step 2. Fuel contaminated.	<ul style="list-style-type: none"> a. Check fuel contamination. If fuel ok, do step 3.
	Step 3. Contact Organizational Maintenance.	
<u>7. ENGINE SURGES AT IDLE</u>		
	Step 1. Low fuel level in the fuel tank.	<ul style="list-style-type: none"> a. Check fuel level in tank. b. Service fuel tank.
	Step 2. Contact Organizational Maintenance.	
<u>8. LOW LUBRICATING OIL PRESSURE</u>		
	Step 1. Incorrect oil level.	<ul style="list-style-type: none"> a. Check engine oil level. If ok, do step 2. b. Add engine oil to correct level. Refer to LO 5-3810-306-12.
	Step 2. Oil diluted with water.	<ul style="list-style-type: none"> a. Inspect for missing oil fill cap, dipstick, etc. If ok, do step 3. b. Contact Organizational Maintenance to drain and refill engine oil.
	Step 3. Oil leak due to loose or missing pipe plug.	<ul style="list-style-type: none"> a. Check for external leak at rear of cylinder head, along fuel pump side of block, oil cooler cover and gear housing. b. Contact Organizational Maintenance.
<u>9. LUBRICATING OIL PRESSURE TOO HIGH</u>		
	Step 1. Engine lubrication system malfunction.	<ul style="list-style-type: none"> a. Contact Organizational Maintenance.

Table 3-1. Operator Troubleshooting - Continued

MALFUNCTION
TEST OR INSPECTION
CORRECTIVE ACTION

10. LUBE OIL LOSS

Step 1. External leaks.

- a. Visually inspect for oil leaks. If no leaks, do step 2.
- b. Contact Organizational Maintenance.

Step 2. Crankcase overfilled.

- a. Remove dipstick and check oil level. Refer to LO 5- 3810-306-12. If ok, do step 3.
- b. Contact Organizational Maintenance to drain engine oil to proper level.

Step 3. Engine lubrication system malfunction.

- a. Contact Organizational Maintenance.
-

11. CONTAMINATED ENGINE OIL

Step 1. Engine lubrication system malfunction.

- a. Contact Organizational Maintenance.
-

12 EXHAUST SMOKE EXCESSIVE UNDER LOAD

Step 1. Engine overloaded.

- a. Downshift to lower gear.

Step 2. Fuel system malfunction.

- a. Contact Organizational Maintenance.
-

13. ENGINE WILL NOT REACH RATED SPEED WHEN LOADED

Step 1. Vehicle overloaded.

- a. Reduce load or downshift to lower gear.

Step 2. Fuel system malfunction.

- a. Contact Organizational Maintenance.
-

Table 3-1. Operator Troubleshooting - Continued

MALFUNCTION	TEST OR INSPECTION	CORRECTIVE ACTION
<u>14. LOW POWER</u>		
	Step 1. Vehicle overloaded.	a. Reduce load or downshift to lower gear.
	Step 2. Engine oil level too high.	a. Remove dipstick and check engine oil level. Refer to LO 5 3810-306-12. If ok, do step 3. b. Contact Organizational Maintenance to drain engine oil to proper level.
	Step 3. Transmission oil level low.	a. With diesel engine running, check transmission oil level. Refer to PMCS for procedure. If ok, do step 4. b. Fill to proper level.
	Step 4. Fuel system malfunction.	a. Contact Organizational Maintenance.
<u>15. ENGINE MISFIRING</u>		
	Step 1. Fuel system malfunction.	a. Contact Organizational Maintenance.
<u>16. FUEL KNOCK</u>		
	Step 1. Engine overloaded.	a. Downshift to lower gear.
	Step 2. Fuel system malfunction.	a. Contact Organizational Maintenance.
<u>17. EXCESSIVE FUEL CONSUMPTION</u>		
	Step 1. Operator Technique.	a. Review Chapter 2-Operating Instructions. If ok, do step 2.
	Step 2. Fuel leak.	a. Inspect for fuel leaks. If ok, do step 3. b. Contact Organizational Maintenance to repair leaks.
	Step 3. Fuel system malfunction.	a. Contact Organizational Maintenance.

Table 3-1. Operator Troubleshooting - Continued

MALFUNCTION
TEST OR INSPECTION
CORRECTIVE ACTION

18. EXCESSIVE VIBRATION

- Step 1. Engine drive component failure.
 - a. Contact Organizational Maintenance.
-

19. EXCESSIVE ENGINE NOISES

- Step 1. Drive belt squeal, insufficient tension or abnormally high loading.
 - a. Check belt tension and condition of drive belt. (Refer to page 3-19.)
 - b. Make sure water pump tensioner pulley, fan hub and alternator turn freely. If ok, do step 2.
 - c. Contact Organizational Maintenance to replace drive belt or tensioner.
 - Step 2. Defective engine.
 - a. Contact Organizational Maintenance.
-

20. FUEL OR OIL LEAKING FROM EXHAUST MANIFOLD

- Step 1. Defective engine.
 - a. Contact Organizational Maintenance.
-

21. COOLANT TEMPERATURE ABOVE NORMAL

- Step 1. Low coolant level.
 - a. Check coolant level. If ok, do step 2.
 - b. Add coolant to proper level.
 - Step 2. Radiator fins damaged or obstructed with debris.
 - a. Inspect radiator fins for damage and debris. If ok, do step 3.
 - b. Clean debris from radiator.
 - c. Contact Organizational Maintenance to replace defective radiator.
 - Step 3. Collapsed radiator hose.
 - a. Inspect upper and lower radiator hoses. If ok, do step 4.
 - b. Contact Organizational Maintenance to replace radiator hose(s).
 - Step 4. Engine oil level too high or too low.
 - a. Remove dipstick and check engine oil level. If ok, do step 5.
 - b. Add engine oil to proper level. Refer to LO 5-3810-306-12.
 - c. Contact Organizational Maintenance to drain engine oil to proper level.
-

Table 3-1. Operator Troubleshooting - Continued

MALFUNCTION	TEST OR INSPECTION	CORRECTIVE ACTION
--------------------	---------------------------	--------------------------

21. COOLANT TEMPERATURE ABOVE NORMAL - CONTINUED

- Step 5. Loose fan drive belt.
- Inspect fan drive belt and belt tensioner. (Refer to page 3-19.) If ok, do step 6.
 - Contact Organizational Maintenance to replace fan drive belt and/or tensioner
- Step 6. Engine overloaded.
- Reduce load and downshift to lower gear.
- Step 7. Defective engine.
- Contact Organizational Maintenance.
-

22. COOLANT LOSS

- Step 1. Radiator leaking coolant.
- Visually inspect radiator hoses and connections to locate leak. If ok, do step 2.
 - Contact Organizational Maintenance to replace radiator components.
- Step 2. External engine leaks.
- Visually inspect engine and components for seal or gasket leaks. If ok, do step 3.
 - Contact Organizational Maintenance to repair leaks.
- Step 3. Turbocharger aftercooler leaks.
- Inspect turbocharger aftercooler, piping and connections for leaks.
 - Contact Organizational Maintenance to repair leaks.
-

23. COOLANT TEMPERATURE BELOW NORMAL

- Step 1. Short runs and intermittent driving.
- Allow diesel engine to warm up properly.
- Step 2. Temperature sensor or gauge malfunction.
- Contact Organizational Maintenance.
-

24. CONTAMINATED COOLANT

- Step 1. Coolant system malfunction.
- Contact Organizational Maintenance to repair coolant system.
-

Table 3-1. Operator Troubleshooting - Continued

MALFUNCTION		
TEST OR INSPECTION		
CORRECTIVE ACTION		

25. ALTERNATOR NOT CHARGING OR INSUFFICIENT CHARGING

- Step 1. Loose or corroded battery connections.
 - a. Inspect battery connection. If ok, do step 2.
 - b. Contact Organizational Maintenance to clean or tighten battery connections.
 - Step 2. Fan drive belt slipping.
 - a. Inspect fan drive belt tensioner by hand. Refer to page 3-19. If ok, do step 3.
 - b. Contact Organizational Maintenance to replace fan drive belt and/or tensioner.
 - Step 3. Alternator pulley loose on shaft.
 - a. Inspect alternator pulley. If ok, do step 4.
 - b. Contact Organizational Maintenance to tighten alternator pulley.
 - Step 4. Charging system malfunction.
 - a. Contact Organizational Maintenance.
-

26. CRANE WILL NOT MOVE OR MOVES ERRATICALLY (TRANSMISSION FAILURE)

- Step 1. Low transmission oil level.
 - a. Remove dipstick and check transmission oil level. Refer to LO 5-3810-306-12. If ok, do step 2.
 - b. Fill to proper level. Refer to LO 5-3810-306-12.
 - Step 2. Transmission shift lever at N-Neutral.
 - a. Check position of transmission shift lever.
 - Step 3. Defective transmission.
 - a. Contact Organizational Maintenance.
-

26A. TRANSMISSION OIL TEMPERATURE ABOVE NORMAL

- Step 1. Low transmission oil level.
 - a. With diesel engine running, check transmission oil level. Refer to PMCS for correct procedure. If ok do step 2.
 - b. Fill to proper level. Refer to LO 5-3810-306-12.
 - Step 2. Transmission not down shifting properly.
 - a. Manually shift to a lower gear.
 - Step 3. Defective transmission.
 - a. Contact Organizational Maintenance.
-

Table 3-1. Operator Troubleshooting - Continued

MALFUNCTION	TEST OR INSPECTION	CORRECTIVE ACTION
<u>27. BRAKES ARE POOR OR DO NOT APPLY</u>		
	Step 1. Insufficient air pressure.	a. Air brake system failure. Contact Organizational Maintenance.
<u>27A. ALL CRANE FUNCTIONS INOPERABLE (NO TWO-BLOCK CONDITION) (RT875CCS)</u>		
	Step 1. LMI Anittwo-block Switch Bypass Flag (Plug) not installed.	a. Verify that bypass flag (plug) is installed, as applicable, in the main boom nose or auxiliary boom nose anti-two block switch to prevent activation of the switch.
<u>28. HARD TO STEER LEFT AND RIGHT</u>		
	Step 1. Hydraulic oil low.	a. Check hydraulic oil level in reservoir, If ok, do step 2. b. Fill hydraulic reservoir to proper level. Refer to LO 5-3810-306-12.
	Step 2. Steering system failure.	a. Contact Organizational Maintenance.
<u>29. REAR STEERING INOPERATIVE</u>		
	Step 1. Hydraulic oil low.	a. Check hydraulic oil level in reservoir. If ok, do step 2. b. Fill hydraulic reservoir to proper level. Refer to LO 5-3810-306-12.
	Step 2. Steering system failure.	a. Contact Organizational Maintenance.
<u>30. SLOW OR ERRATIC OPERATION OF OUTRIGGER CYLINDERS</u>		
	Step 1. Low hydraulic oil.	a. Check hydraulic oil level. If ok, do step 2. b. Fill hydraulic reservoir to proper level. Refer to LO 5-3810-306-12.
	Step 2. Outrigger cylinder rods and/or beams dirty.	a. Clean outrigger cylinder rods and/or beams.
	Step 3. Outrigger system malfunction.	a. Contact Organizational Maintenance.
<u>31. JACK CYLINDER RETRACTS UNDER LOAD</u>		
	Step 1. Outrigger system malfunction.	a. Contact Organizational Maintenance.

Table 3-1. Operator Troubleshooting - Continued

MALFUNCTION

TEST OR INSPECTION

CORRECTIVE ACTION

32. JACK CYLINDER EXTENDS WHILE MACHINE IS TRAVELING

- Step 1. Outrigger system malfunction.
- a. Contact Organizational Maintenance.
-

33. OUTRIGGER SYSTEM WILL NOT OPERATE

- Step 1. Hydraulic oil low.
- a. Check hydraulic oil level. If ok, do step 2.
 - b. Fill hydraulic reservoir. Refer to LO 5-3810-306-12.
- Step 2. Outrigger system malfunction.
- a. Contact Organizational Maintenance.
-

34. OUTRIGGER SYSTEM ACTIVATES, BUT SELECTED OUTRIGGER WILL NOT RETRACT OR EXTEND AND LOWER AS DESIRED

- Step 1. Outrigger system malfunction.
- a. Contact Organizational Maintenance.
-

35. OUTRIGGERS WILL NOT SET

- Step 1. Improper sequence of activation.
- a. Activate individual control switch; then activate EXTEND/RETRACT switch.
-

36. BOOM RAISES OR LOWERS ERRATICALLY

- Step 1. Hydraulic oil low.
- a. Check hydraulic oil level. If ok, do step 2.
 - b. Fill hydraulic reservoir. Refer to LO 5-3810-306-12.
- Step 2. Low engine rpm.
- a. Increase engine rpm.
- Step 3. Hydraulic system failure.
- a. Contact Organizational Maintenance.
-

Table 3-1. Operator Troubleshooting - Continued

MALFUNCTION	TEST OR INSPECTION	CORRECTIVE ACTION
<u>37. BOOM RAISES OR LOWERS SLOWLY</u>		
	Step 1. Low hydraulic oil.	<ul style="list-style-type: none"> a. Check hydraulic oil level. If ok, do step 2. b. Fill hydraulic reservoir. Refer to LO 5-3810-306-12.
	Step 2. Low engine rpm.	<ul style="list-style-type: none"> a. Increase engine rpm.
	Step 3. Cold hydraulic oil.	<ul style="list-style-type: none"> a. Operate crane to bring oil to operating temperature.
	Step 4. Hydraulic system failure.	<ul style="list-style-type: none"> a. Contact Organizational Maintenance.
<u>38. BOOM WILL NOT RAISE OR LOWER</u>		
	Step 1. Low hydraulic oil.	<ul style="list-style-type: none"> a. Check hydraulic oil level. If ok, do step 2. b. Fill hydraulic reservoir. Refer to LO 5-3810-306-12.
	Step 2. Excessive load.	<ul style="list-style-type: none"> a. Reduce load as required. Refer to Appendix F.
	Step 3. Hydraulic system failure.	<ul style="list-style-type: none"> a. Contact Organizational Maintenance.
<u>39. ERRATIC OPERATION OF TELESCOPING CYLINDER</u>		
	Step 1. Low hydraulic oil.	<ul style="list-style-type: none"> a. Check hydraulic oil level. If ok, do step 2. b. Fill hydraulic reservoir. Refer to LO 5-3810-306-12.
	Step 2. Low engine rpm.	<ul style="list-style-type: none"> a. Increase engine rpm.
	Step 3. Air in telescope cylinder.	<ul style="list-style-type: none"> a. Lower boom so telescope cylinder is below horizontal, then cycle cylinder.
	Step 4. Lack of lubrication on boom section.	<ul style="list-style-type: none"> a. Lubricate boom sections. Refer to LO 5-3810-306-12.
	Step 5. Side loading causing improper boom alignment.	<ul style="list-style-type: none"> a. Reduce load. Refer to Appendix F. Use proper hoisting procedures.
	Step 6. Hydraulic system failure.	<ul style="list-style-type: none"> a. Contact Organizational Maintenance.

Table 3-1. Operator Troubleshooting - Continued

MALFUNCTION
TEST OR INSPECTION
CORRECTIVE ACTION

40. TELESCOPE CYLINDER WILL NOT EXTEND OR RETRACT

- Step 1. Low hydraulic oil level.
 - a. Check hydraulic oil level. If ok, do step 2.
 - b. Fill hydraulic oil level. Refer to LO 5-3810-306-12.
 - Step 2. Excessive load.
 - a. Reduce load. Refer to Appendix F.
 - Step 3. Hydraulic system failure.
 - a. Contact Organizational Maintenance.
-

41. HOIST WILL NOT RAISE LOAD

- Step 1. Load capacity exceeded.
 - a. Reduce load. Refer to Appendix F.
 - Step 2. Incorrect LMI setting – Not enough parts of hoist line specified.
 - a. Correct LMI setting for reeving (parts of line). Refer to page 2-47.
 - Step 3. Low hydraulic oil.
 - a. Check hydraulic oil level. If ok, do step 4.
 - b. Fill hydraulic reservoir. Refer to LO 5-3810-306-12.
 - Step 4. Too much cable on hoist drum.
 - a. Reduce amount of cable on hoist drum (line pull increases).
 - Step 5. Hydraulic system failure.
 - a. Contact Organizational Maintenance.
-

42. HOIST WILL NOT LOWER LOAD.

- Step 1. Malfunctioning hoist brake.
 - a. If necessary, perform Emergency Load Lowering Procedures (Refer to page 2-59 – RT875CCS or 2-61 – RT875CC).
 - b. Contact Organizational Maintenance.
-

43. SLOW OR ERRATIC HOIST OPERATION

- Step 1. Low engine rpm.
 - a. Increase rpm.
 - Step 2. Low hydraulic oil.
 - a. Check hydraulic oil level. If ok, contact Organizational Maintenance.
 - b. Fill hydraulic reservoir. Refer to LO 5-3810-306-12.
-

Table 3-1. Operator Troubleshooting - Continued

MALFUNCTION	TEST OR INSPECTION	CORRECTIVE ACTION
<u>44. BOOM SWING OPERATIONS ERRATIC IN EITHER DIRECTION</u>		
	Step 1. Low engine rpm.	a. Increase engine rpm.
	Step 2. Low hydraulic oil.	a. Check hydraulic oil level. If ok, do step 3. b. Fill hydraulic reservoir. Refer to LO 5-3810-306-12.
	Step 3. Insufficient lubricant on swing bearing.	a. Inspect swing bearing. Lubricate bearing. Refer to LO 5-3810-306-12.
	Step 4. Crane not level.	a. Level crane using outriggers (Refer to page 2-50).
	Step 5. Crane overloaded.	a. Reduce load (Refer to Appendix F).
	Step 6. Swing system failure.	a. Contact Organizational Maintenance.
<u>45. SWING BRAKE SYSTEM WILL NOT OPERATE.</u>		
	Step 1. Low hydraulic oil.	a. Check hydraulic oil level. If ok, do step 2. b. Fill hydraulic reservoir. Refer to LO 5-3810-306-12.
	Step 2. Swing system failure.	a. Contact Organizational Maintenance.
<u>46. CAB HEATER STOPS OR DOES NOT START</u>		
	Step 1. Fuel tank empty.	a. Check fuel tank level and fill as required. If ok, do step 2.
	Step 2. Heater failure.	a. Contact Organizational Maintenance.
<u>46.1. CAB HEATER FAILS TO START – MOTOR DOES NOT RUN (RT875CCS)</u>		
	Step 1. Blown fuse.	a. Check condition of fuse in heater control panel. If ok, do step 2. b. If fuse is blown, investigate condition that may have caused fuse to blow. Then replace fuse with spare.
	Step 2. Heater failure.	a. Contact Organizational Maintenance.

Table 3-1. Operator Troubleshooting - Continued

MALFUNCTION		
TEST OR INSPECTION		
CORRECTIVE ACTION		

46.2. CAB HEATER FAILS TO START – MOTOR RUNS (RT875CCS)

- Step 1. Improper starting sequence.
 - a. Review cab heater starting sequence.
 - Step 2. Heater fuel tank empty.
 - a. Check fuel tank and fill as required. If ok, do step 3.
 - Step 3. Heater failure.
 - a. Contact Organizational Maintenance.
-

47. CAB HEATER EXHAUSTS BLACK SMOKE

- Step 1. Improper fuel (RT875CCS)
 - a. Check heater fuel tank for type of fuel used. If ok, do step 2
 - b. Contact Organizational Maintenance to either drain the heater fuel tank or to adjust the heater carburetor to burn a different fuel.
 - Step 2. Heater failure.
 - a. Contact Organizational Maintenance.
-

NOTE

The error codes listed below are able to be corrected by a crane operator. If an error code appears on the LMI console that is not listed below, it indicates a fault in the LMI system, contact Organizational Maintenance.

48. ERROR CODE E01 ON LMI MOMENT DISPLAY

- Step 1. Minimum radius or maximum angle exceeded due to raising the boom too far.
 - a. Lower boom to a radius or angle given in the load chart. Refer to Appendix F.
 - Step 2. Load moment indicator system malfunction.
 - a. Contact Direct Support Maintenance.
-

49. ERROR CODE E02 ON LMI MOMENT DISPLAY

- Step 1. Maximum radius or minimum angle exceeded due to lowering boom too far.
 - a. Raise boom to a radius or angle given in the load chart. Refer to Appendix F.
 - Step 2. Load moment indicator system malfunction.
 - a. Contact Direct Support Maintenance.
-

Table 3-1. Operator Troubleshooting - Continued

MALFUNCTION	TEST OR INSPECTION	CORRECTIVE ACTION
<u>50. ERROR CODE E04 ON LMI MOMENT DISPLAY</u>		
	Step 1. Operating mode switches on console set incorrectly.	a. Set operating mode switches to match operation mode of crane. Refer to Table 2-2.
	Step 2. Load moment indicator system malfunction.	a. Contact Direct Support Maintenance.
<u>51. ERROR CODE E05 ON LMI MOMENT DISPLAY</u>		
	Step 1. Maximum or minimum boom length exceeded.	a. Telescope boom to correct length given in load chart. Refer to Appendix F.
	Step 2. Load moment indicator system malfunction.	a. Contact Direct Support Maintenance.
<u>52. ERROR CODE E80 ON LMI LOAD DISPLAY</u>		
	Step 1. Indicates load on hook is below 9,000 lbs.	a. No corrective action required. Information code only.
<u>53. ERROR CODE EEE ON LMI MOMENT DISPLAY (RT875CC)</u>		
	Step 1. Actual load exceeds 200% of rated machine capacity at a given operating condition.	a. Correct to operate within approved load chart and operating conditions. Refer to Appendix F.
	Step 2. Load moment indicator system malfunction.	a. Contact Direct Support Maintenance.
<u>53. ERROR CODE E89 ON LMI MOMENT DISPLAY (RT875CCS)</u>		
	Step 1. Change in operating code while lifting load caused by changing operating modes while actively lifting a load.	a. Lower the load and reset the operating mode correctly in accordance with the procedures contained on page 2-47.

Section III – MAINTENANCE PROCEDURES

INTRODUCTION

This section contains maintenance procedures which are the responsibility of the operator. The operator shall be responsible for maintaining the good running order of all functions and features of the Container Crane, following the procedures provided here. When a malfunction occurs that is beyond the scope of these procedures (and thus beyond your responsibility) report that malfunction to your supervisor to be serviced by a higher maintenance level.

WARNING

Be sure you are wearing the proper eye protection devices before starting maintenance procedures in order to insure personal safety.

To ensure good running order, perform your PMCS.

Consult the PMCS for guidance in determining whether or not the crane is available for operation.

ENGINE INSPECTION AND SERVICE

ENGINE INSPECTION

1. Open engine access doors and inspect the following:
 - a. Oil fill cap is secure.
 - b. Oil dipstick is secure.
 - c. All electrical wiring is secure.
 - d. Coolant fill cap is secure.
 - e. Evidence of oil, fuel, and coolant leaks.
2. Close engine access doors and secure.

AIR CLEANER ASSEMBLY

1. Check the air restriction indicator. If red line is low on the scale, have Organizational Maintenance replace filter elements.
2. Inspect vacuator valve. The valve lips should be open only when the engine is shut down or running at low idle speed. If the valve is turned inside out, check for a clogged air cleaner inlet. Malfunction of this

valve does not reduce the air cleaner effectiveness, but does allow the element to get dirty faster and reduces serviceable life. If a valve is lost or damaged, have Organizational Maintenance replace it with a new valve of the same part number.

3. Check the air cleaner intake pipe caps and screens for accumulation of leaves and other debris that could restrict air flow. Have Organizational Maintenance repair screens or replace caps if any large holes are found in the screen.
4. Check mounting hardware for security to eliminate possible vibration of intake piping. Such vibration leads to early failure of hoses, clamps and mounting parts, and can cause hoses to slip off the connecting pipes, allowing unfiltered air into the engine air intake.
5. Check hoses for cracks, chafing or deterioration, and have Organizational Maintenance replace at the first sign of probable failure.

FUEL

FUEL SUPPLY

Check fuel level. If necessary, add diesel fuel. IGNITION SWITCH must be OFF when adding fuel.

FUEL FILTER-WATER SEPARATOR (RT875CC)

Draining

The fuel filter-water separator should be drained daily, 30 minutes after the engine is shut down, to remove any water and sediment. Proceed as follows:

1. Open drain valve, 1/4 turn.
2. Drain until fuel appears.
3. Close drain valve. Do not over-tighten.

NOTE

Drain the fuel heater water separator (RT875CCS) in accordance with Operator daily PMCS.

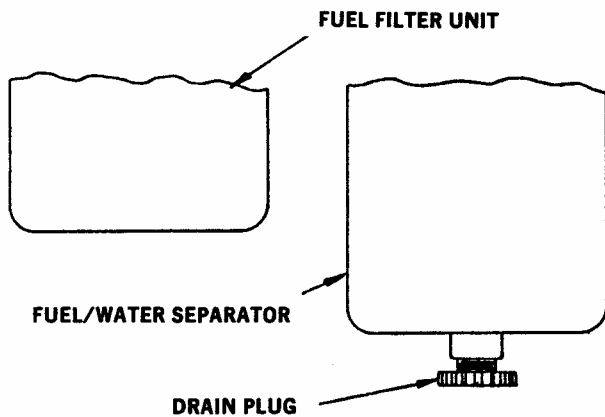

Fuel Filter/Water Separator (RT875CC)

EXHAUST SYSTEM MUFFLER AND PIPES

Inspect muffler and pipes for the following:

1. Check all supports and hangers are intact.
2. Check for exhaust leaks. Look for excessive corrosion, holes and misaligned parts.

COOLING SYSTEM

Coolant Supply

Check when cool. The coolant expansion tank is on the left side of the hood. If below FULL when cold, add coolant (50/50 mix of antifreeze AFC, MIL-A-46153, and clean water).

RADIATOR

1. Inspect radiator and hoses for secure mounting.
2. Check for coolant leaks at hose, pipe fittings and joints.

FAN DRIVE BELT

1. With engine off, press long vertical run of fan belt on right side of engine and measure belt deflection.
2. If deflection exceeds 1/4-inch, the belt is either stretched or belt tensioner is defective. In either case, contact Organizational Maintenance.

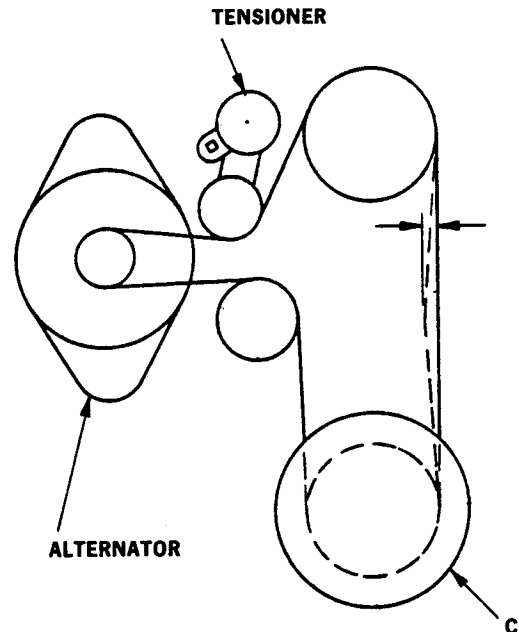

ELECTRICAL SYSTEM

SENDING UNITS AND WARNING SWITCHES

The LED alert display performs a five-second self-test of the alarm indicators and audible alarm when the engine IGNITION switch is on. When these indicators turn off due to normal operation the warning switches are working successfully.

1. With IGNITION SWITCH-ON and engine running ensure that panel gauges operate properly. This confirms the sending units are functional.

HORNS AND ALARMS

1. With IGNITION switch ON and blackout light switch in either SERV DRIVE or STOP LIGHT positions, press horn button. Horn should sound.
2. With transmission direction lever in R (reverse), engine running and blackout light switch in either SERV DRIVE or STOP LIGHT position, backup alarm should sound.

BATTERIES

Deleted

TRANSMISSION SERVICE

1. Check oil level in transmission. This should be done with the oil temperature gauge reading between 180-200 degrees F. Add oil if level is below FULL mark on dipstick.

HYDRAULIC FLUID COOLER

1. Inspect for leaks and dirt fouling the air path through the oil cooler.

AIR RESERVOIR SERVICE

1. Check for moisture in air system by opening the reservoir's drain cock or automatic drain valve. Use a tool to drain the automatic drain valve. Move the wire in the exhaust port up, holding it until draining is complete. In areas where more than a 30 degree temperature range is common, small amounts of water can condense in air system. Small amounts of water are normal and are not an indication that the dryer is not working.

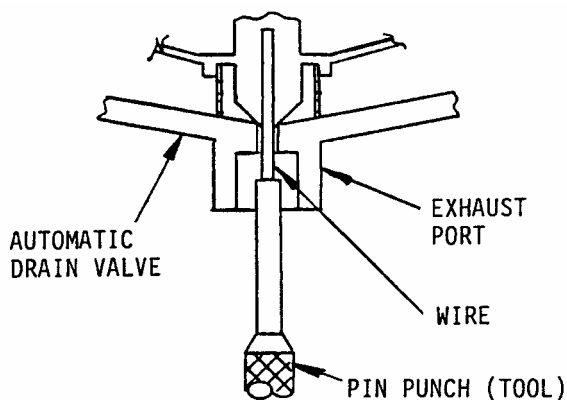

Automatic Drain Valve

2. Have Organizational Maintenance replace the desiccant cartridge in the air dryer when it has been determined that the desiccant is contaminated and cannot absorb water.

TIRES

1. Inspect tires for damage and wear. Refer to PMCS for proper guidance. If you are not sure about tire serviceability, contact your supervisor or maintenance to inspect the crane's tires.
2. Check air pressure in each tire. Pressure should be 75 psi.

WARNING

The rim is made up of three pieces with a locking ring. If not properly seated, the locking ring and rim parts can fly apart with lethal force. Always use a tire inflation cage and clip on inflator. Failure to follow this procedure could result in personnel injury.

3. If low, place tire inflation cage around tire and using clip on inflator, fill tire to 75 psi.
4. Have maintenance check torque of wheel lug nuts. This torque should be 325 ft-lbs (44.9 kgm), dry.

STEERING SYSTEM

HYDRAULIC HOSES, LINES AND FITTINGS

1. Inspect for leaks, loose fittings and damaged hoses.

FRAME

OUTRIGGERS

1. Inspect outriggers for smooth operation, lubrication, clean cylinder rods and no hydraulic leaks.

OUTRIGGER FLOATS

1. Inspect outrigger floats and their locking collars for damage and loose parts.

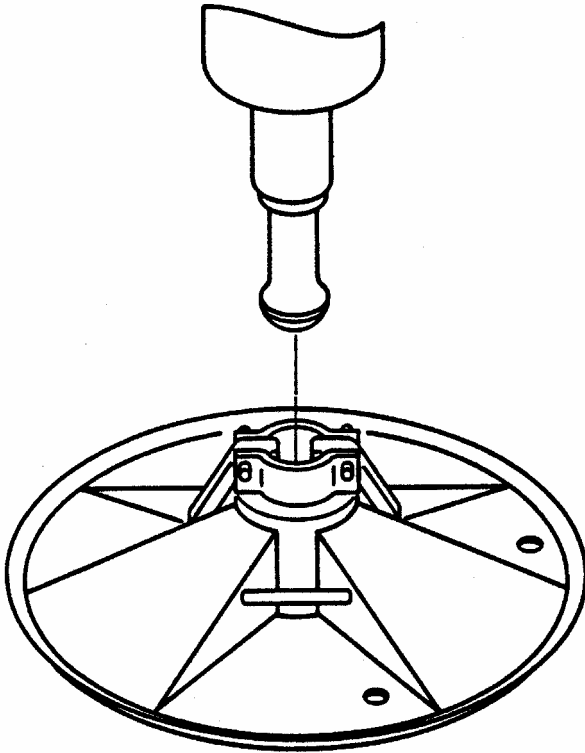

Outrigger Float

BODY, CAB, HOOD AND HULL

DOOR ASSEMBLY WITH LATCH/HANDLE

1. Inspect for loose or missing weatherstripping, loose door, latch and/or handle. Ensure door slide moves freely without binding, and that door latch locks.

FRONT CONSOLE

1. Inspect for loose mounting screws, loose gauge mounts, loose lever mechanisms, torn rubber boots on levers, broke switches and knobs.

HOOD ASSEMBLY

1. Inspect for loose screws, fittings, attachments and corrosion.

FENDERS AND REAR DECKING INSTALLATION

1. Inspect for loose screws, fittings, attachments and corrosion.

SEAT ASSEMBLY

1. Inspect for loose screws, torn upholstery and broken slides. Inspect seat belt buckle and belt fabric for wear. Ensure that the seat slides freely on its tracks.

FIRE EXTINGUISHER

1. Inspect charge indicator. Pointer should be in green zone.
2. Inspect for loose mounting, damage to hose, nozzle, etc.

BODY, CHASSIS, OR HULL AND ACCESSORY ITEMS

ACCESSORY ITEMS

1. Inspect windshield wiper blades on both the front window and skylight; replace if worn.
2. Operate control switches for wipers and for windshield washer.
3. Check washer fluid level in bottle in the valve compartment and fill if needed.

CAB HEATER/DEFROSTER

1. Inspect for evidence of fuel leaks, exhaust leaks and rust corrosion.

CAB HEATER FUEL TANK

1. Inspect fuel supply. If low, add diesel fuel.
2. Inspect for fuel leaks, loose mounting, loose tubing and fillings, etc.

HYDRAULIC SYSTEM

HYDRAULIC CONTROL VALVES

1. Ensure all components are secure and there are no leaks.

STRAINERS, FILTERS, LINES AND FITTINGS SERVICE

1. Ensure all components are secure and there are no leaks. Check filter indicator on hydraulic reservoir; if white indicator is at or below the halfway mark on the window have Organizational Maintenance replace filter element.

HYDRAULIC LIFT CYLINDERS

1. Ensure all components are secure and not leaking.
2. Inspect cylinder rod for dirt and/or scoring.
3. Inspect oil seals for accumulated dirt and clean if needed.

HYDRAULIC TELE CYLINDER

1. Ensure all components are secure and not leaking.
2. Inspect cylinder rod for dirt and/or scoring.
3. Inspect oil seals for accumulated dirt and clean if necessary.

HYDRAULIC RESERVOIR

1. Inspect reservoir level sight gauge. If level is low, add oil. Inspect breather cap on top of the reservoir; clean if necessary.

LOAD MOMENT INDICATOR (LMI) SYSTEM

1. Inspect inter-connecting electrical cables for damage and security.
2. Inspect length sensor cable for damaged insulation.
3. Inspect cable guides for damage that may cause damage to length sensor cable and for security.
4. Check for freedom of movement of anti-two block switches.
5. Check that cable reel is operating under tension.
6. Inspect the pressure transducers for hydraulic leaks and damaged hoses.

CRANE ATTACHMENTS

BOOM INSPECTION

1. Ensure all components of boom are secure and in good condition
2. Inspect for corrosion, dirt and oil leaks.
3. Inspect the telescope section for adequate lubrication of bottom plates; inspect telescope and base section contact area for evidence of wear, cracks, warping or other damage. Excessive wear may be indicative of worn/missing boom wear pads.
4. Check boom nose sheaves for security and freedom of movement.

BOOM SERVICE

1. Where bottom plates lack lubrication add grease. Refer to Lubrication Order L05-3810-306-12.

GUIDES AND ROLLER

1. Ensure all components are secure and in good condition; look for dirt, grease, cracks scoring or grooving.

HOOK BLOCK INSPECTION

1. Inspect hook block; ensure all components are secure and in good condition. Look for freedom of movement of sheaves, hook and hook latch. Inspect for hook distortion and cracks.

HOOK BLOCK SERVICE

1. IF HOOK IS CRACKED OR DISTORTED, CALL ORGANIZATIONAL MAINTENANCE IMMEDIATELY.

SWING SYSTEM TEST

1. Check swing system operation by engaging the swing brake control, then position swing control lever in both directions. Superstructure rotation should not occur. Then disengage the swing brake control and swing the superstructure in both directions. Use the swing brake to stop rotation.

END OF TASK

APPENDIX A

REFERENCES

A-1. SCOPE

This appendix lists forms, field manuals, technical manuals, and other publications referenced in this manual and which apply to organizational maintenance of the RT875CC/RT875CCS Rough Terrain Container Crane.

A-2. DEPARTMENT OF THE ARMY PAMPHLETS

Consolidated Index of Army Publications and Blank Forms	DA Pam 25-30
Using Unit Supply System (Manual Procedures)	DA Pam 710-2-1
The Army Maintenance Management System (TAMMS)	DA Pam 750-8

A-3. FORMS

Recommended Changes to Publications and Blank Forms	DA Form 2028
Organizational Control Record for Equipment	DA Form 2401
Equipment Inspection and Maintenance Worksheet	DA Form 2404
Maintenance Request	DA Form 2407
Preventive Maintenance Schedule and Record	DD Form 314
Product Quality Deficiency Report (NSN 7540-00-105-0078)	SF 368

A-4. FIELD MANUALS

NEC Contamination Avoidance	FM 3-11.3
NEC Protection	FM 3-11.4
NEC Decontamination	FM 3-11.5
Camouflage	FM 20-3
Operation and Maintenance of Ordnance Materiel in Cold Weather (0° to -65° F). First Aid for Soldiers	FM 9-207 FM 4-25.11
Manual for the Wheeled Vehicle Driver	FM 21-305
Basic Cold Weather Manual	FM 31-70
Northern Operations	FM 31-71
Army Motor Transport Units and Operations	FM 55-30
Desert Operations	FM 90-3
Mountain Operations (How to Fight)	FM 3-97.6

A-4. FIELD MANUALS (CONTINUED)

Vehicle Recovery Operation FM 4-30.31

A-5. TECHNICAL BULLETINS

Tactical Wheeled Vehicles: Repair of Frames TB 9-2300-247-30

Equipment Improvement Report and Maintenance
Digest (US Army Tank-Automotive Command)
Tank-Automotive EquipmentTB 43-0001-39 series

Color, Marking, and Camouflage Painting of
Military Vehicles, Construction Equipment, and
Materials Handling Equipment TB 43-0209

Maintenance in the Desert TB 43-0239

A-6. TECHNICAL MANUALS

Inspection, Care, and Maintenance of Antifriction Bearings TM 9-214

Materials Used for Cleaning, Preserving, Abrading, and
Cementing Ordnance Material and Related Materials, Including Chemicals TM 9-247

Operator's, Unit, Direct Support, and General Support for
Care, Maintenance, and Repair of Pneumatic Tires and Inner Tubes TM 9-2610-200-14

Painting Instructions for Field Use TM 43-0139

Procedures for Destruction of Tank-Automotive Equipment to Prevent Enemy Use TM 750-244-6

Operator's Manual for Container Crane, 40 Ton, Rough Terrain,
Models RT875CC and RT875CCS TM 5-3810-306-10

Lubrication Order for Container Crane, 40 Ton,
Rough Terrain, Models RT8755CC and RT875CCS LO 5-3810-306-12

Transportability TM 55-3810-306

A-7. SPECIFICATIONS AND STANDARDS

Dry Cleaning Solvent (Type III)..... Fed Spec F-D-680

Methyl Ethyl Ketone, Technical TT-M-261

Inspection, Liquid Penetrant Methods MIL-I-6866

Inspection Process, Magnetic Particles MIL-I-6868

Human Engineering Design Criteria for Military Systems, Equipment and Facilities MIL-STD-1472

A-8. OTHER PUBLICATIONS

Army Medical Department Expendable/Durable Items	CTA 8-100
Expendable/Durable Items (Except Medical, Class V, Repair Parts, and Heraldic Items	CTA 50-970

APPENDIX B

COMPONENTS OF END ITEM AND BASIC ISSUE ITEMS LIST

SECTION I. INTRODUCTION

B-1. SCOPE

This appendix lists components of the end item and basic issue items for the Container Crane to help you inventory items required for safe and efficient operation.

B-2. GENERAL

The Components of End Item and Basic Issue Items Lists are divided into the following sections:

- a. Section II. Components of End Item. This listing is for informational purposes only, and is not authority to requisition replacements. These items are part of the end item, but are removed and separately packaged for transportation or shipment. As part of the end item, these items must be with the end item whenever it is issued or transferred between property accounts. Illustrations are furnished to assist you in identifying the items.
- b. Section III. These are the minimum essential items required to place the Container Crane in operation, to operate it, and to perform emergency repairs. Although shipped separately packaged, BII must be with the Container Crane during operation and whenever it is transferred between property accounts. The illustrations will assist you with hard-to-identify items. This manual is your authority to request/requisition replacement BII, based on TOE/MTOE authorization of the end item.

B-3. EXPLANATION OF COLUMNS

The following provides an explanation of columns found in the tabular listings:

- a. Column (1) - Illustration Number (Illus Number). This column indicates the number of the illustration in which the item is shown.
- b. Column (2) - National Stock Number. Indicates the National Stock Number assigned to the item and will be used for requisitioning purposes.
- c. Column (3) - Description. Indicates the Federal item name and, if required, a minimum description to identify and locate the item. The last line for each item indicates the Contractor And Government Entity (CAGE) code (in parentheses) followed by the part number.
- d. Column (4) - Unit of Measure (U/M). Indicates the measure used in performing the actual operational/maintenance function. This measure is expressed by a two-character alphabetical abbreviation (e.g., ea, in, pr).
- e. Column (5) - Quantity required (Qty rqr). Indicates the quantity of the item authorized to be used with/on the equipment.

SECTION II. COMPONENTS OF END ITEM

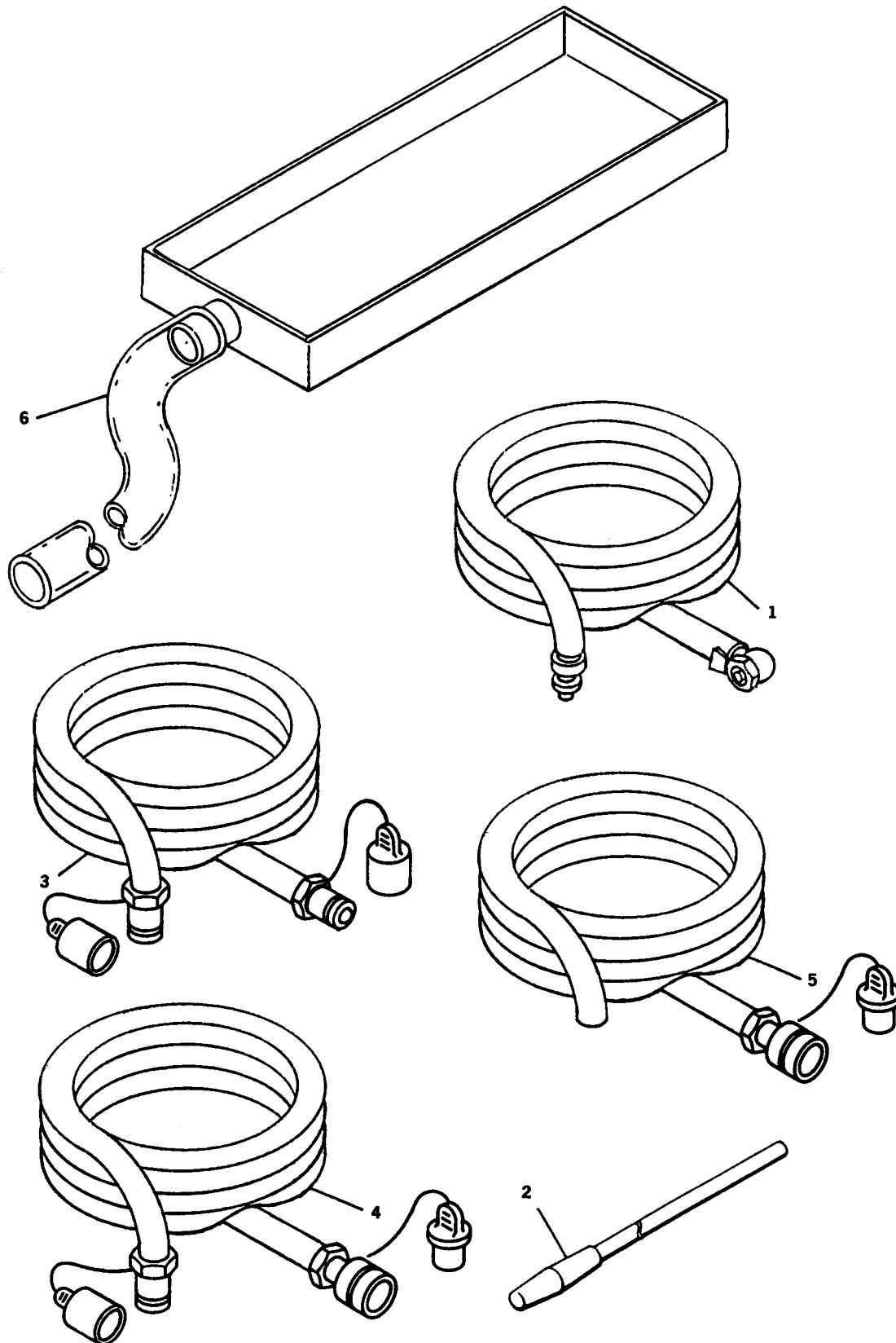

(1) ILLUS NUMBER	(2) NATIONAL STOCK NUMBER	(3) DESCRIPTION CAGE AND PART NUMBER	(4) U/M	(5) QTY RQR
1	4720-01-268-7399 4720-01-477-6720 4910-01-268-7498 4730-01-311-0219	Tire Inflation Air Chuck and Hose (Tool Box) Consists of: Hose (RT875CC) Hose, Coiled (RT875CCS) Inflator, Gage Chuck, Air	EA EA EA EA	1 1 1 1
2	4320-01-282-1730	Handle, Hand Hydraulic Pump (Tool Box) (RT875CC) (Part of Entire Hydraulic Pump Assembly)	EA	1
3	4720-01-304-5539	Hose, Hydraulic, Pump – 38 Ft. (Tool Box) (RT875CC)	EA	1
4	4720-01-304-5540	Hose, Hydraulic, Pump – 18 Ft. (Tool Box) (RT875CC)	EA	1
5	4720-01-304-5541	Hose, Hydraulic, Bleeddown – 12 Ft. (Tool Box) (RT875CC)	EA	1
6	2815-01-324-6892 4710-01-281-7888	Hoist Drain Pan (Tool Box) (RT875CC) Consists of: Pan Drain Tube	EA EA	1 1

SECTION III. BASIC ISSUE ITEMS

NONE

APPENDIX C

ADDITIONAL AUTHORIZATION LIST

SECTION I. INTRODUCTION

C-1. SCOPE

This appendix lists additional items you are authorized for the support of the Container Crane.

C-2. GENERAL

This list identifies items that do not have to accompany the Container Crane and that do not have to be turned in with it. These items are all authorized to you by CTA, MTOE, TDA, or JTA.

C-3. EXPLANATION OF LISTING

National stock numbers, descriptions, and quantities are provided to help you identify and request the additional items you require to support this equipment. The items are listed in alphabetical sequence by item name under the type document (i.e., CTA, MTOE, TDA, or JTA) which authorizes the item(s) to you.

SECTION II. ADDITIONAL AUTHORIZATION LIST

(1) NATIONAL STOCK NUMBER	(2) DESCRIPTION CAGE & PART NUMBER	(3) U/M	(4) QTY AUTH
<u>MTOE AUTHORIZED ITEMS</u>			
7520-00-559-9618	Bag, Pamphlet	EA	1
4240-00-052-3776	Goggles, Eye Protection	PR	2
8415-00-889-3767	Helmet, Construction	EA	2
6545-00-922-1200	Kit, First Aid	EA	1
<u>CTA AUTHORIZED ITEMS</u>			
NONE			

APPENDIX D

EXPENDABLE SUPPLIES AND MATERIALS LIST

D-1. SCOPE

This appendix lists expendable supplies and materials you will need to operate and maintain the Container Crane. These items are authorized to you by CTA 50-970, Expendable Items (Except Medical, Class V, Repair Parts, and Heraldic Items).

D-2. EXPLANATION OF COLUMNS

- a. Column (1)-Item number. This number is assigned to the entry in the listing and is referenced in the narrative instructions to identify the material (e.g., "Use cleaning compound, item 5, APP. D").
- b. Column (2)-Level. This column identifies the lowest level of maintenance that requires the listed item.

C - Operator/Crew
O - Organizational Maintenance
F - Direct Support Maintenance
H - General Support Maintenance
- c. Column (3)-National Stock Number. This is the National stock number assigned to the item; use it to request or requisition the item.
- d. Column (4)-Description. Indicates the Federal item name and, if required, a description to identify the item. The last line for each item indicates the Contractor And Government Entity (CAGE) code in parentheses followed by the part number.
- e. Column (5)-Unit of Measure (U/M). Indicates the measure used in performing the actual maintenance function. This measure is expressed by a two-character alphabetical abbreviation (e.g., ea, in, pr). If the unit of measure differs from the unit of issue, requisition the lowest unit of issue that will satisfy your requirements.

APPENDIX D

EXPENDABLE MATERIAL LIST

(1) ITEM NUMBER	(2) LEVEL	(3) NATIONAL STOCK NUMBER (NSN)	(4) DESCRIPTION	(5) U/M
1	C	9150-01-048-4591 9150-01-035-5395 9150-01-035-5396	OIL: Multipurpose Gear Lube (MPL) GO 85W/140 (81349) MIL-L-2105 / MIL-PRF-2105 Turntable Swing Gear Box (15 Qts) Main and Aux. Hoists – Final Drive (10 Qts) Axle Drive Units (Differential) (30 Qts) Axle Planetary Ends (58 Pts) 1 Quart Can 5 Gallon Can 55 Gallon Drum	QT GAL GAL
2	C	9150-01-152-4117 9150-01-152-4118 9150-01-152-4119	OIL: Engine EO/HDO 15W/40 (81349) MIL-L-2104 Engine Crankcase (23.7 Qts) 1 Quart Can 5 Gallon Can 55 Gallon Drum	QT GAL GAL
3	C	9150-00-189-6727 9150-00-186-6668 9150-00-191-2772	OIL: Engine EO/HDO 10 (81349) MIL-L-2104 / MIL-PRF-2104 Transmission / Torque Converter (8.6 Qts) Swing Brake (1/2 Pt) Hydraulic Reservoir (165 Gallons) 1 Quart Can 5 Gallon Can 55 Gallon Drum	QT GAL GAL
4	C	6850-00-181-7929 6850-00-181-7933	ANTIFREEZE: Permanent Ethylene Glycol, Inhibited, Heavy Duty (81349) MIL-A-46153 1 Gallon Can 55 Gallon Drum	GAL GAL
5	C		SPC – Anti-Seize Lube (MIL-A-907C)	

EXPENDABLE MATERIAL LIST (CONTINUED)

(1) ITEM NUMBER	(2) LEVEL	(3) NATIONAL STOCK NUMBER (NSN)	(4) DESCRIPTION	(5) U/M
6	C	9150-01-197-7688 9150-01-197-7693 9150-01-197-7690 9150-01-197-7689 9150-01-197-7692	GREASE: Automotive and Artillery GAA MPG – Multipurpose Grease (MIL-PRF-10924) (81349) MIL-G-10924 1-1/4 Ounce Tube 14 Ounce Tube 2-1/4 Pound Can 6-1/2 Pound Can 35 Pound Pail	OZ OZ LB LB LB
7	C	9150-00-402-4478 9150-00-402-2372 9150-00-491-7197	OIL: Lubricating, Arctic, OEA (81349) MIL-L-46167 Engine Crankcase (23.7 Qts) Transmission / Torque Converter (8.6 Gals) 1 Quart Can 5 Gallon Drum 55 Gallon Drum	QT GAL GAL
8	C		OEA Engine Oil (MIL-L-46167)	
9	C	6850-01-377-1808 6850-01-331-3349 6850-01-331-3350	SOLVENT: Dry Cleaning, Type III (81348) P-D-680 1 Quart Can 5 Gallon Can 55 Gallon Drum	QT GAL GAL

APPENDIX E

STOWAGE AND SIGN GUIDE

E-1. SCOPE

This appendix shows the locations for stowage of equipment and materiel required to be carried on the Container Crane.

E-2. GENERAL

The pictures below and on the following pages (E-1 through E-5) show the location of decals, stencils, and metal signs used on the RT875CC crane. Pages E-6 through E-21 contain the decals, stencils, and signs for the RT875CCS crane. The illustrations contained on these pages are intended to assist you in identifying and locating the decal/sign on the crane.

Most of these signs are cautions or information you need to operate the crane safely. Some mark the places where equipment should be stowed. Number callouts refer to the legend on page E-5.

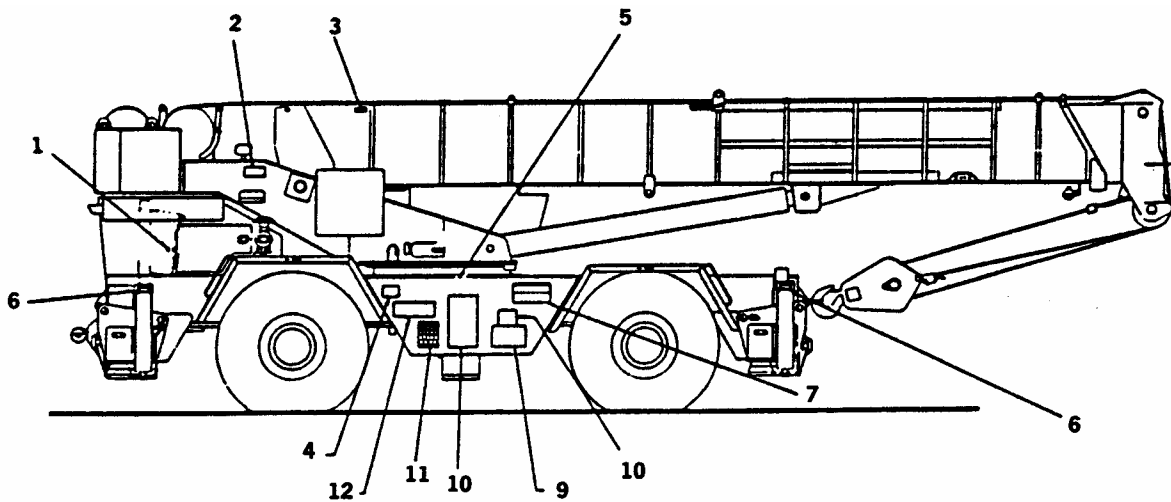

Right Side View (RT875CC)

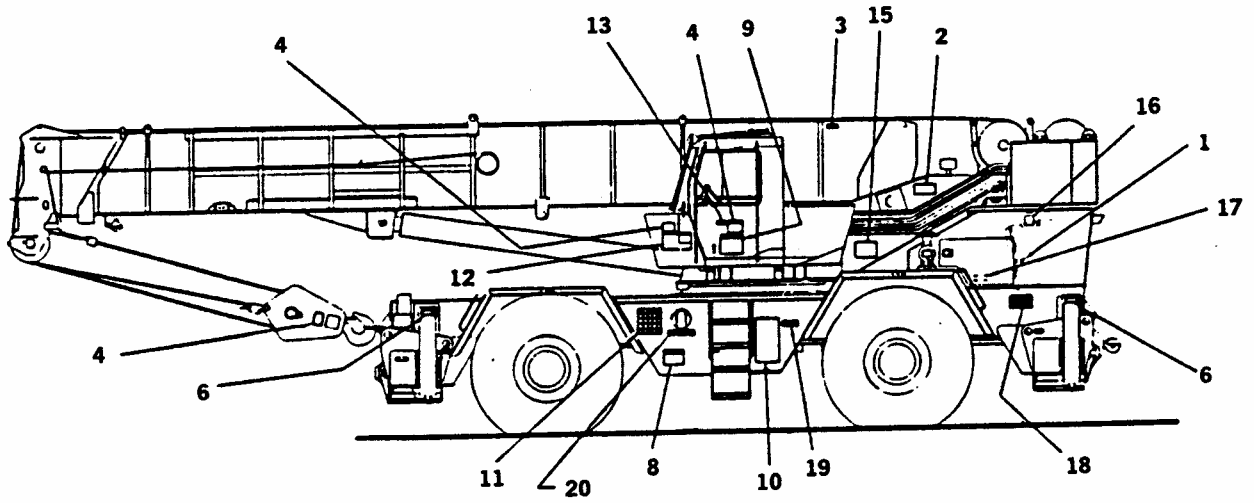

LEFT SIDE (RT875CC)

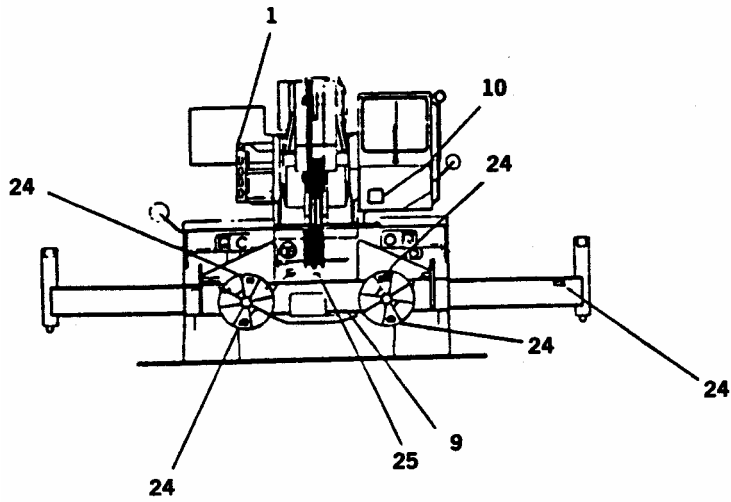

FRONT VIEW (RT875CC)

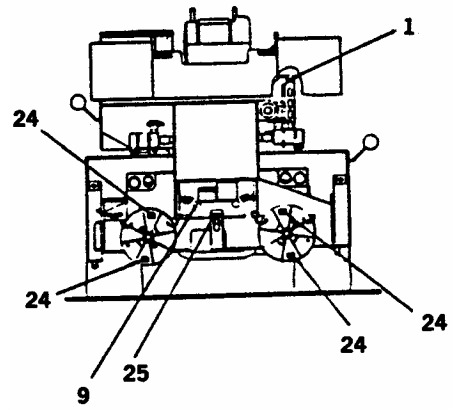

REAR VIEW (RT875CC)

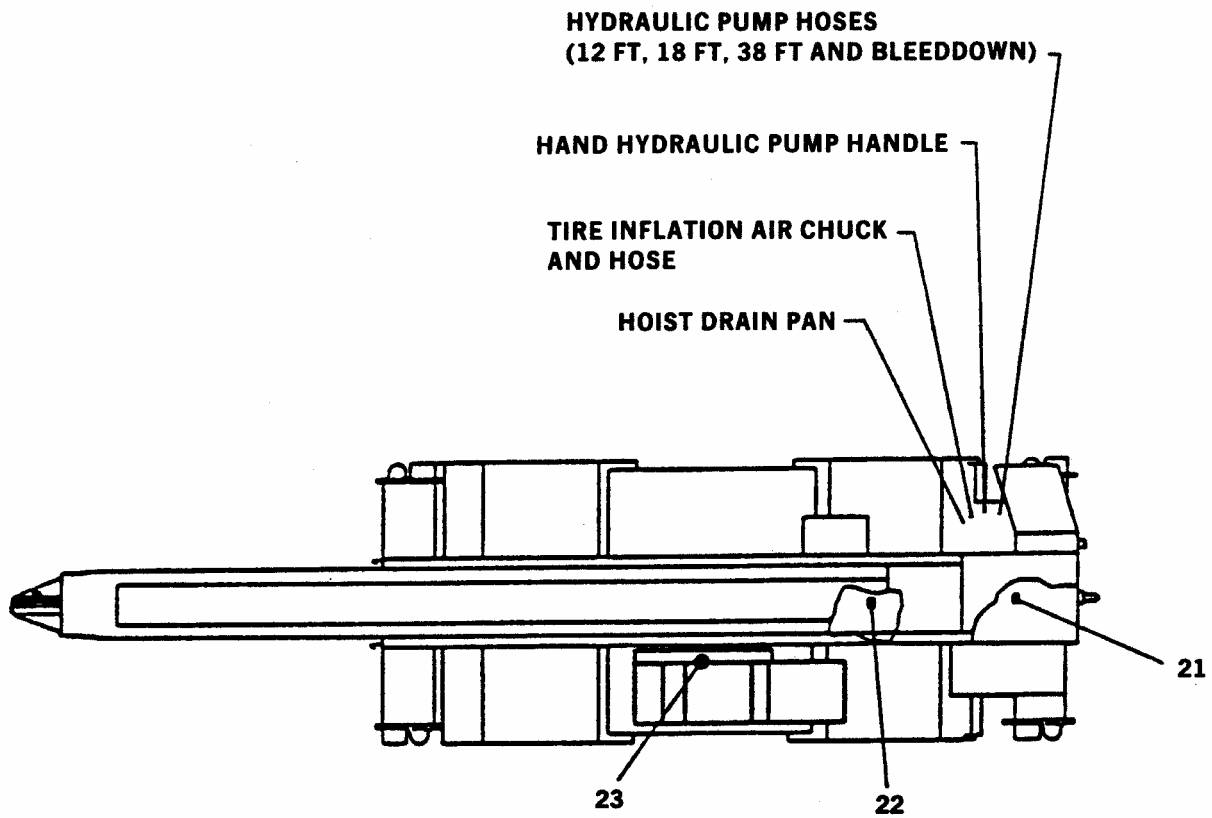

TOP VIEW (RT875CC)

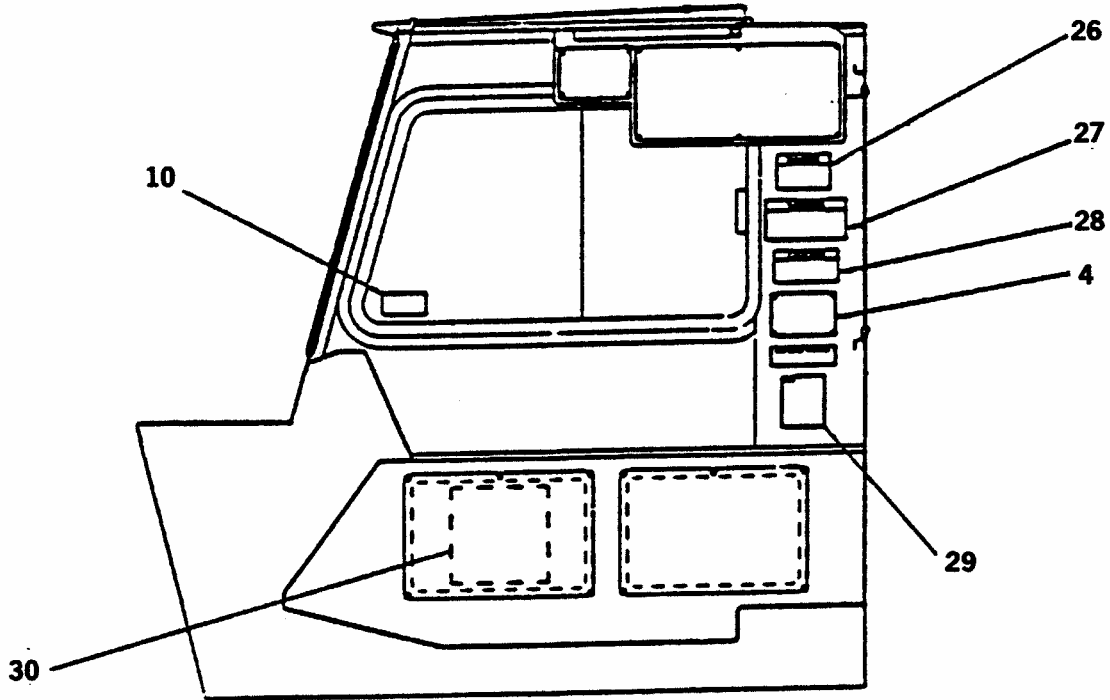

INSIDE -- R.H. SIDE CAB

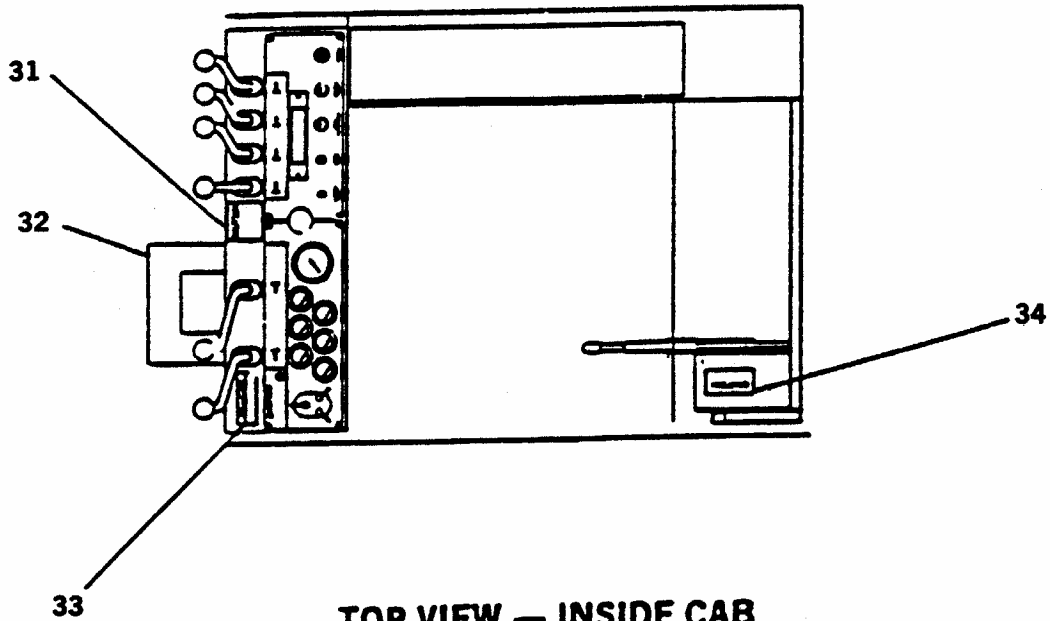

TOP VIEW -- INSIDE CAB

TOP VIEW -- INSIDE CAB (RT875CC)

STOWAGE AND SIGN GUIDE (RT875CC) (Cont'd)

LEGEND

- | | |
|------------------------------|----------------------------|
| 1. Fan Decal | 18. Slave Receptacle Decal |
| 2. Rotating Machine Decal | 19. Transmission Decal |
| 3. Boom Not A Walkway Decal | 20. Diesel Decal |
| 4. Identification Decal | 21. Radiator Coolant Decal |
| 5. Hydraulic Fill Decal | 22. Pump Disconnect Decal |
| 6. Warning Decal | 23. Emergency Exit Decal |
| 7. Lube Chart Decal | 24. No Step Decal |
| 8. Danger Decal | 25. No Lifting Decal |
| 9. Warning Nameplate | 26. Danger Decal |
| 10. Electrical Warning Decal | 27. Steep Grades Decal |
| 11. Hand Signals Decal | 28. S/S Demount Decal |
| 12. Shipping Data Decal | 29. Patents Decal |
| 13. Hearing Protection Decal | 30. Electrical Decal |
| 14. Caution Nameplate | 31. Fender Damage Decal |
| 15. Heater Fuel Decal | 32. No-Load Travel Decal |
| 16. Radiator Decal | 33. Swing Horn Decal |
| 17. Oil Filter Decal | 34. Swing Lock Decal |

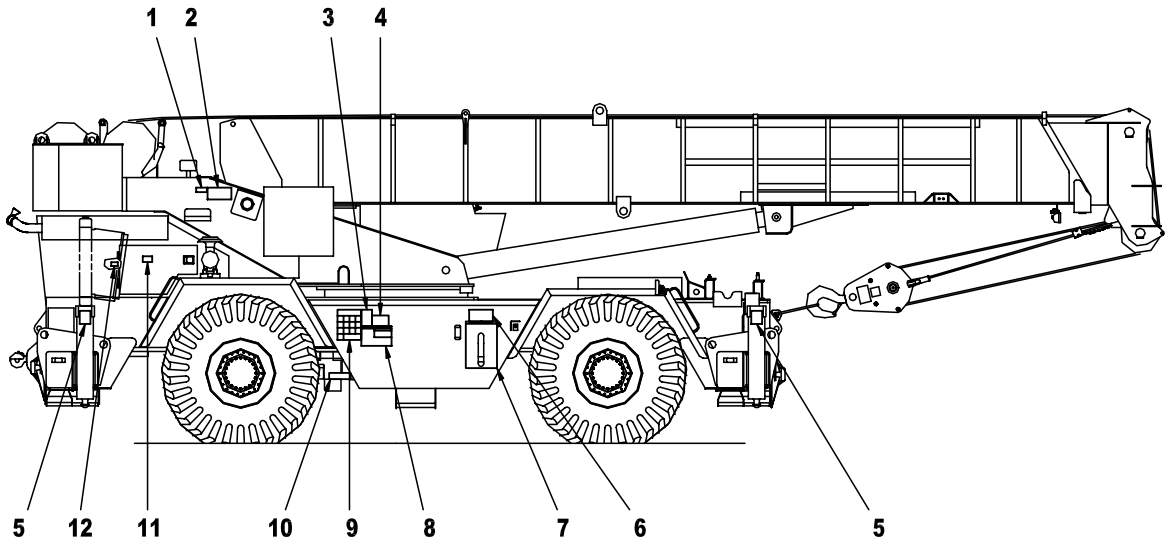

RIGHT SIDE VIEW

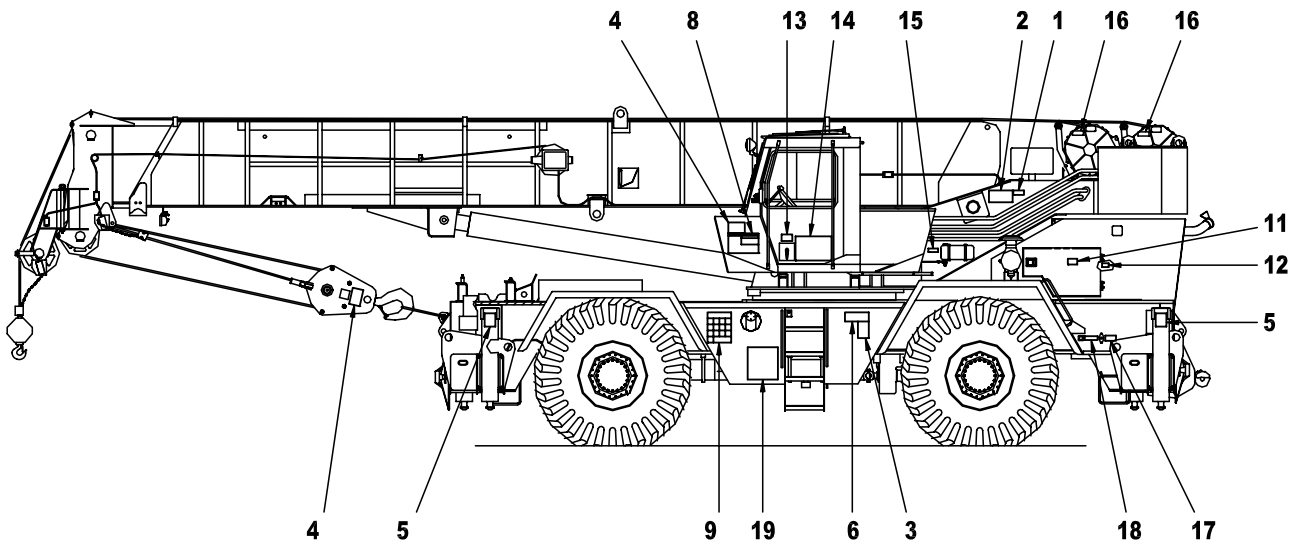

LEFT SIDE VIEW

RT875CCS

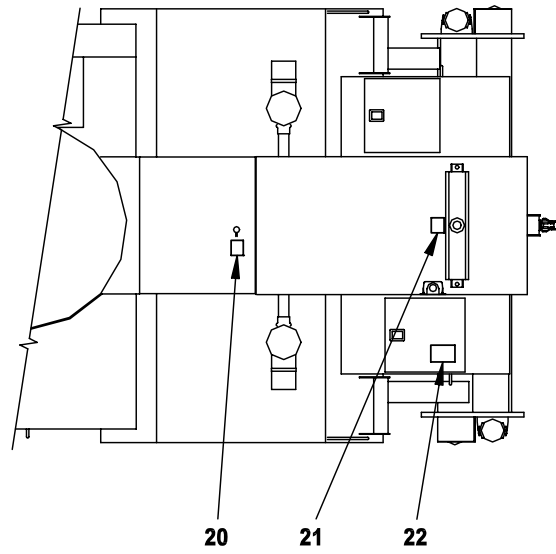

PLAN VIEW (CARRIER)

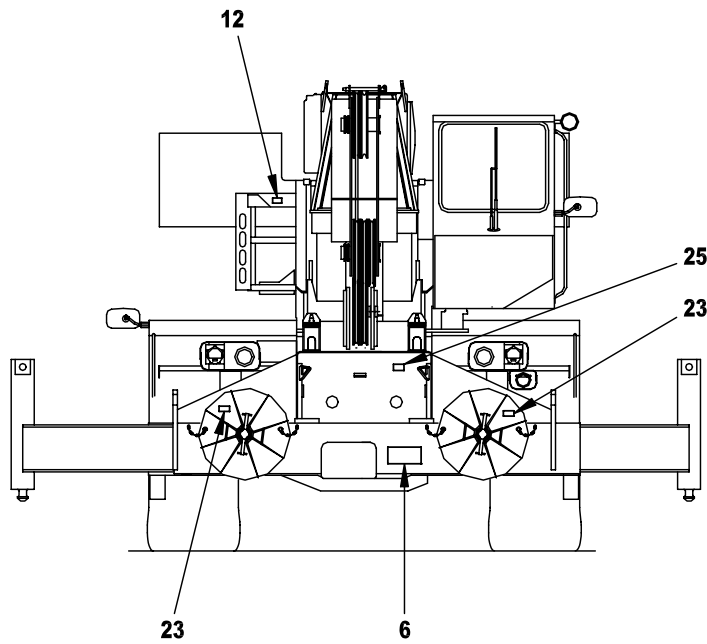

FRONT VIEW

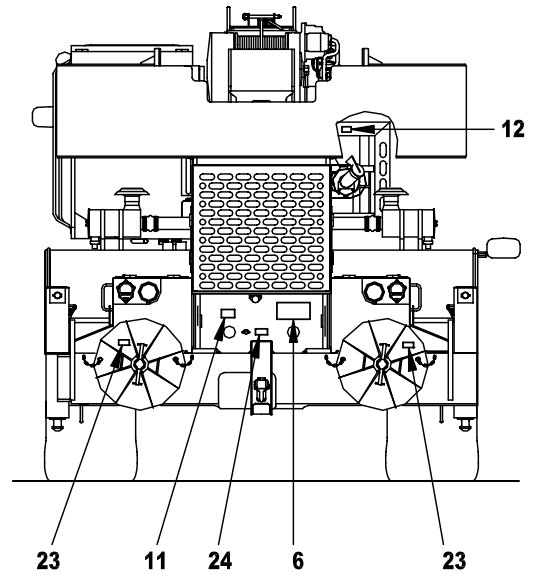

REAR VIEW

RT875CCS

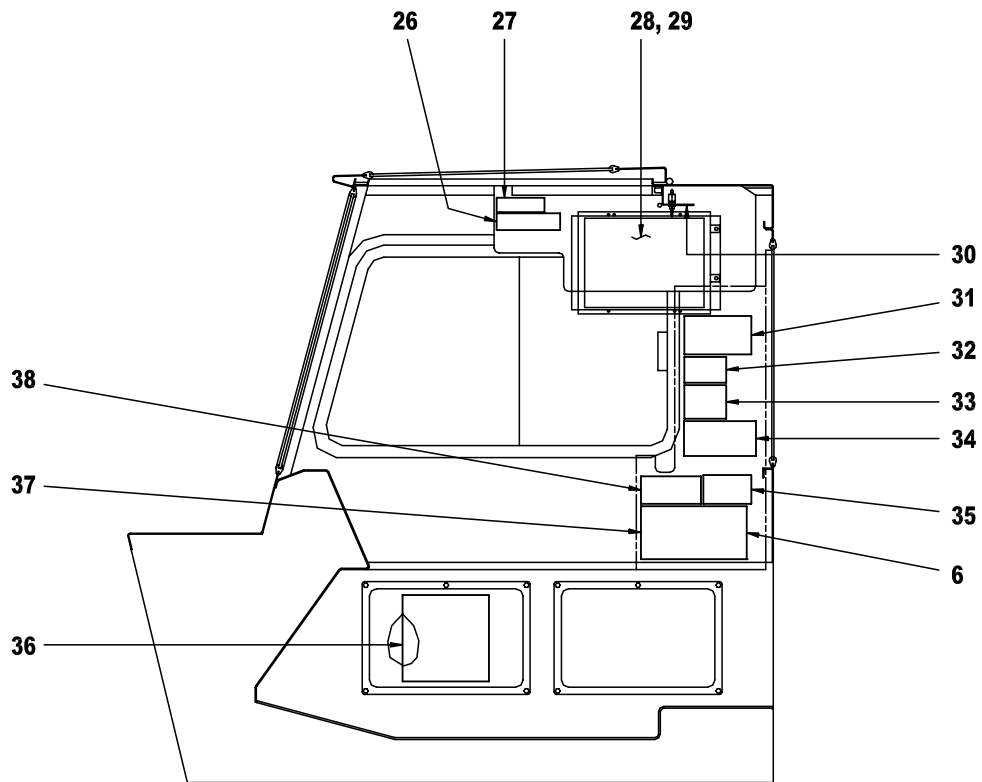

INSIDE RIGHT HAND SIDE OF CAB

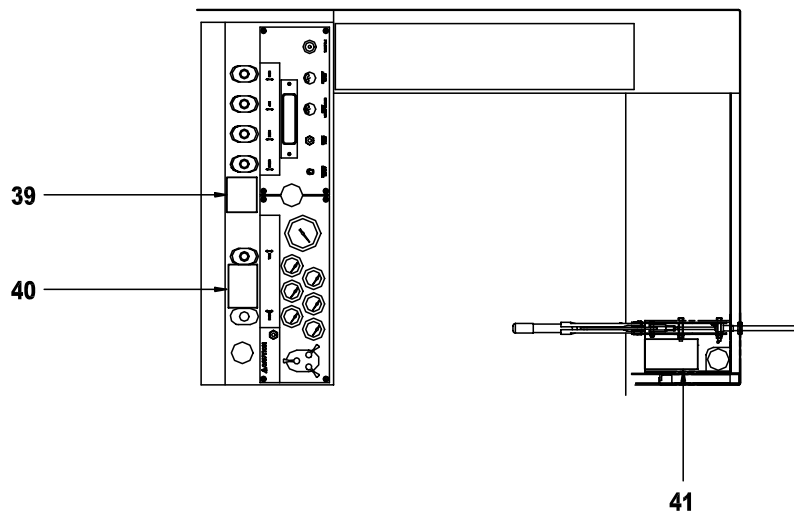

PLAN VIEW - INSIDE CAB

RT875CCS



Item No. 1 – Danger Boom Not A Walkway

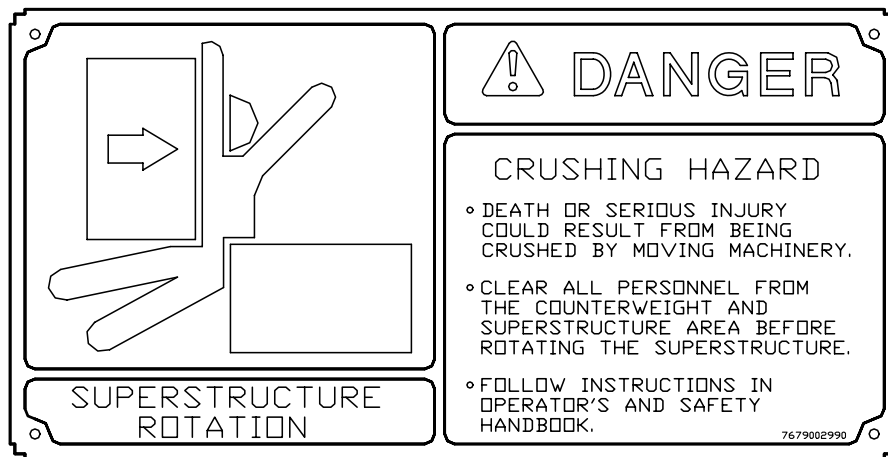

Item No. 2 – Danger Crushing Hazard

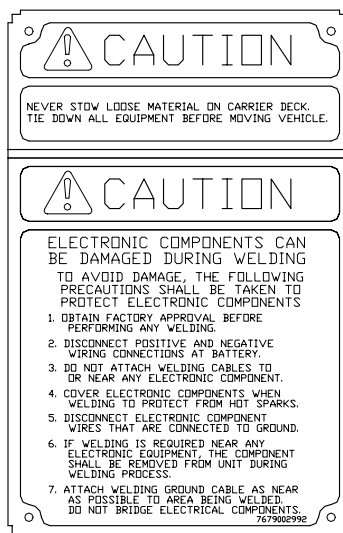

Item No. 3 – Caution Loose Materials/Electronic Equipment

CONTAINER CRANE, ROUGH TERRAIN, WHEEL MOUNTED, HYDRAULIC, DIESEL POWERED			
COMPONENT	1234567890123456	MFR. GROVE U.S. L.L.C.	12345
NSN	3810-01-205-2716	US REG. NO.	123456
DESIGN ACTIVITY	12345	MFR. PT. NO.	1234567890123
MFR. CONTRACT	1234567890123456	SERIAL NO.	1234567
SLEP CONTRACT	1234567890123456	MFR. DATE	123456789
CARC	123456789	SLEP DATE	123456789
WARRANTED ITEM: WARRANTY PERIOD 12 MONTHS FROM 123456789 DATE OF GOVERNMENT ACCEPTANCE			
7679100139			

Item No. 4 – Warranty Data Plate



Item No. 5 – Danger Crushing Hazard/Outriggers

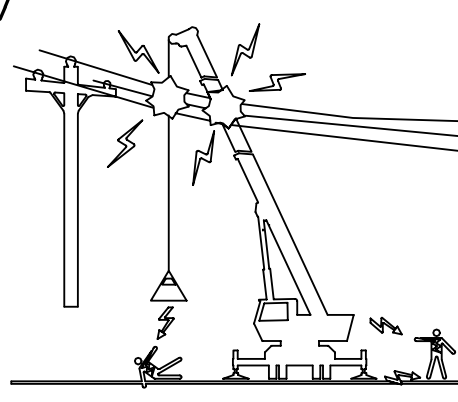

⚠ DANGER

ELECTROCUTION HAZARD

TO AVOID DEATH OR SERIOUS INJURY, KEEP ALL PARTS OF THIS CRANE, THE RIGGING, AND MATERIALS BEING LIFTED AT LEAST 20 FEET AWAY FROM ALL ELECTRICAL POWER LINES AND EQUIPMENT.

KEEP AWAY FROM THIS CRANE IF IT IS BEING OPERATED NEAR ELECTRICAL POWER LINES OR EQUIPMENT.

BEFORE OPERATING THIS CRANE IN THE VICINITY OF POWER LINES OR EQUIPMENT, NOTIFY THE POWER UTILITY COMPANY. HAVE POWER TURNED OFF.

FOLLOW INSTRUCTIONS IN OPERATOR'S AND SAFETY HANDBOOK.

THIS CRANE IS NOT INSULATED.

7679002987

Item No. 6 – Danger Electrocution Hazard

SERVICE & LUBRICATION CHART- RT875CCS											
SERVICE INTERVAL	ITEM NO.	COMPONENT	NIL-SYMBOL/ACTION	SERVICE	INTERVAL	SERVICE INTERVAL	ITEM NO.	COMPONENT	NIL-SYMBOL/ACTION	SERVICE	INTERVAL
DAILY	1	ENGINE OIL	DE-AD-10-10	CHECK/FILL	1	1	1	ENGINE OIL	DE-AD-10-10	BRN/FILL	1
	3	ENGINE COOLING SYSTEM	ANTI-FREEZE COOLANT	CHECK/FILL	1	2	2	ENGINE OIL FILTER	REPLACE	REPLACE	1
	5	FUEL WATER SEPARATOR	-----	CHECK/DRN	1	4	4	ENGINE OIL FILTER	REPLACE	REPLACE	1
	9	TRANSMISSION/TORQUE CONVERTER	DE-AD-10	CHECK/FILL	1	10	10	TORQUE CONVERTER OIL FILTER	-----	REPLACE	1
	25	HYDRAULIC OIL FILTER ELEMENT	-----	CHECK/REPLACE	1	11	11	TRANSMISSION SPEED SENSOR DRIVE	GAA	LUBE OILSD	1
30 HRS	27	HYDRAULIC RESERVOIR	DE-AD-10	CHECK/FILL	1	14	14	AXLE CARRIER JOINTS	GAA	LUBE OILSD	4
	30	TURNTABLE SWING DRIVE GEARBOX CASE	GD-85/140	CHECK/FILL	1	15	15	AXLE KINGPIN BUSHINGS-LOWER	GAA	LUBE OILSD	4
	32	SWING BRAKE	DE-AD-10	CHECK/FILL	1	16	16	AXLE KINGPIN BUSHINGS-UPPER	GAA	LUBE OILSD	4
	34	HOOK BLOCK SHEAVES	GAA	LUBE OILSD	3	17	17	AXLE TIE ROD ENDS	GAA	LUBE OILSD	4
	35	HOOK BLOCK THROUSERS	GAA	LUBE OILSD	2	18	18	BEVEE SHAFT SLIP JOINTS	GAA	LUBE OILSD	3
30 HRS	36	HOOK BLOCK THROUSERS	GAA	LUBE OILSD	2	23	23	PISTON RING DRAIN	GAA	LUBE OILSD	1
	37	HEADSAIL BLOCK SHEAVES	GAA	LUBE OILSD	1	48	48	WIRE ROPE LUBRICANT	LUBE OILSD	2	
	38	SHEAVES (MAIN BOOM NOSE)	GAA	LUBE OILSD	5	3	3	ENGINE COOLING SYSTEM	ANTI-FREEZE COOLANT	DRNG SPECIFC	1
	39	SHEAVES (AUXILIARY BOOM NOSE)	GAA	LUBE OILSD	1	4	4	ENGINE COOLANT FILTER	-----	REPLACE	1
	40	AXLE DIFFERENTIALS	GD-85/140	CHECK/FILL	2	5	5	FUEL FILTER (PRIMARY)	-----	REPLACE	1
30 HRS	41	AXLE WHEEL END BEARINGS	GD-85/140	CHECK/FILL	4	6	6	FUEL FILTER (SECONDARY)	-----	REPLACE	1
	42	BEAR AXLE 5TH WHEEL PIVOT BEARING	GAA	LUBE OILSD	2	30	30	TURNTABLE SWING DRIVE GEARBOX CASE	GD-85/140	BRN/FILL	1
	43	BEAR AXLE 5TH WHEEL LOCK-OUT CYLINDER PIVOT PIN	GAA	LUBE OILSD	4	45	45	HEIST DRAIN	GD-85/140	BRN/FILL	1
	44	STEER CYLINDER ENDS	GAA	LUBE OILSD	8	46	46	HEIST (AUXILIARY)	GD-85/140	BRN/FILL	1
	45	OUTRIGGER BEAMS	GAA	LUBE OILSD	4	8	8	COMPRESSED AIR BRVER NECESSARY	-----	CHECK	1
30 HRS	46	OUTRIGGER JACK SUPPORT TUBES	GAA	LUBE OILSD	4	9	9	TRANSMISSION/TORQUE CONVERTER	DE-AD-10	BRN/FILL	1
	47	PISTON RING DRAIN	GAA	LUBE OILSD	2	11	11	AXLE DIFFERENTIALS	GD-85/140	BRN/FILL	2
	48	TURNTABLE SWING BEARING	GAA	LUBE OILSD	2	13	13	AXLE WHEEL END BEARINGS	GD-85/140	BRN/FILL	4
	49	TURNTABLE GEAR/DRIVE SHAFT	GAA	LUBE OILSD	2	27	27	HYDRAULIC RESERVOIR	DE-AD-10	BRN/FILL	1
	50	TURNTABLE SWING DRIVE GEARBOX PIVOT SHAFT	GAA	LUBE OILSD	1	3	3	ENGINE COOLING SYSTEM	ANTI-FREEZE COOLANT	BRN/FILL	1
30 HRS	51	FOOTVAL COUPLING	GAA	LUBE OILSD	1	8	8	COMPRESSED AIR BRVER NECESSARY	-----	REPLACE	1
	52	BOOM WEAR PADS (ASSEMBLY)	ANTI-SEIZ COMPOUND	LUBE OILSD	2	22	22	OUTRIGGER BEAMS	GAA	LUBE OILSD	4
	53	BOOM WEAR PADS (NON-ASSEMBLY)	ANTI-SEIZ COMPOUND	LUBE OILSD	2	23	23	OUTRIGGER JACK SUPPORT TUBES	GAA	LUBE OILSD	4
	54	BOOM PIVOT BUSHINGS	GAA	LUBE OILSD	2	25	25	PISTON RING DRAIN	GAA	LUBE OILSD	1
	55	BOOM LIFT CYLINDER PIVOT-UPPER	GAA	LUBE OILSD	2	29	29	TURNTABLE GEAR/DRIVE SHAFT	GAA	LUBE OILSD	2
30 HRS	56	BOOM LIFT CYLINDER PIVOT-LOWER	GAA	LUBE OILSD	2	42	42	BOOM WEAR PADS (ALL)	ANTI-SEIZ COMPOUND	LUBE OILSD	2
	57	HEIST TIE ROD ENDS	GAA	LUBE OILSD	2	7	7	ENGINE AIR CLEANER ELEMENT	DE-AD/REPLACE	1	
	58	HEIST TIE ROD ROLLERS	GAA	LUBE OILSD	2	<p style="font-size: 0.7em; margin: 0;">IN ADDITION TO SPECIFIED ROUTINE SERVICE INTERVALS LISTED ABOVE, THE FOLLOWING SERVICE INTERVALS APPLY TO THE CRANE. THESE INTERVALS ARE BASED ON THE OPERATOR'S DAILY INSPECTION AND MAINTENANCE OF THE CRANE.</p>					
	59	ENGINE AIR CLEANER ELEMENT	DE-AD/REPLACE	1	<p style="font-size: 0.7em; margin: 0;">ITEM NO. COMPONENT 30 HRS 30 HRS 30 HRS 30 HRS 30 HRS</p>						
	60	ENGINE AIR CLEANER ELEMENT	DE-AD/REPLACE	1	<p style="font-size: 0.7em; margin: 0;">NIL-SYMBOL DESCRIPTION NIL-SPEC</p>						

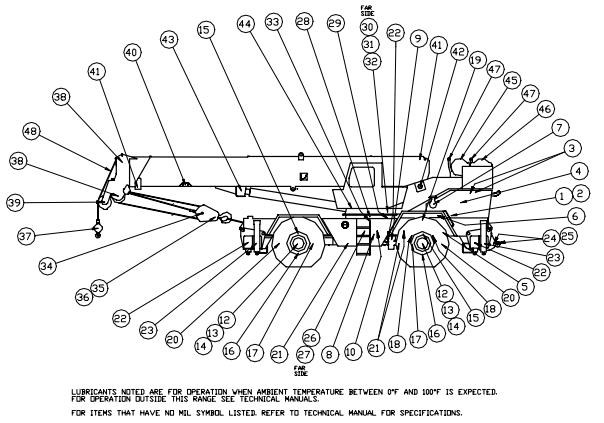

LUBRICANTS NOTED ARE FOR OPERATION WHEN AMBIENT TEMPERATURE BETWEEN 0° AND 100° F IS EXPECTED. FOR OPERATION OUTSIDE THIS RANGE SEE TECHNICAL MANUALS.

FOR ITEMS THAT HAVE NO NIL SYMBOL LISTED, REFER TO TECHNICAL MANUAL FOR SPECIFICATIONS.

WHERE SERVICE INTERVAL SPECIFIES TWO CRITERIA (E.G. HOURS AND MONTHS) SPECIFIED SERVICE SHALL TAKE PLACE ACCORDING TO WHICHEVER CRITERION OCCURS FIRST.

THESE LUBE INTERVALS ARE TO BE USED AS A GUIDELINE ONLY. ACTUAL LUBE INTERVALS SHALL BE FORMULATED BY MAINTENANCE PERSONNEL ACCORDING TO PARTICULAR CONDITIONS SUCH AS CONTINUOUS DUTY CYCLES AND/OR AGGRESSIVE ENVIRONMENTS. CONSULT TECHNICAL MANUALS FOR DETAILS INSTRUCTIONS.

767900100

Item No. 7 – Lubrication Chart

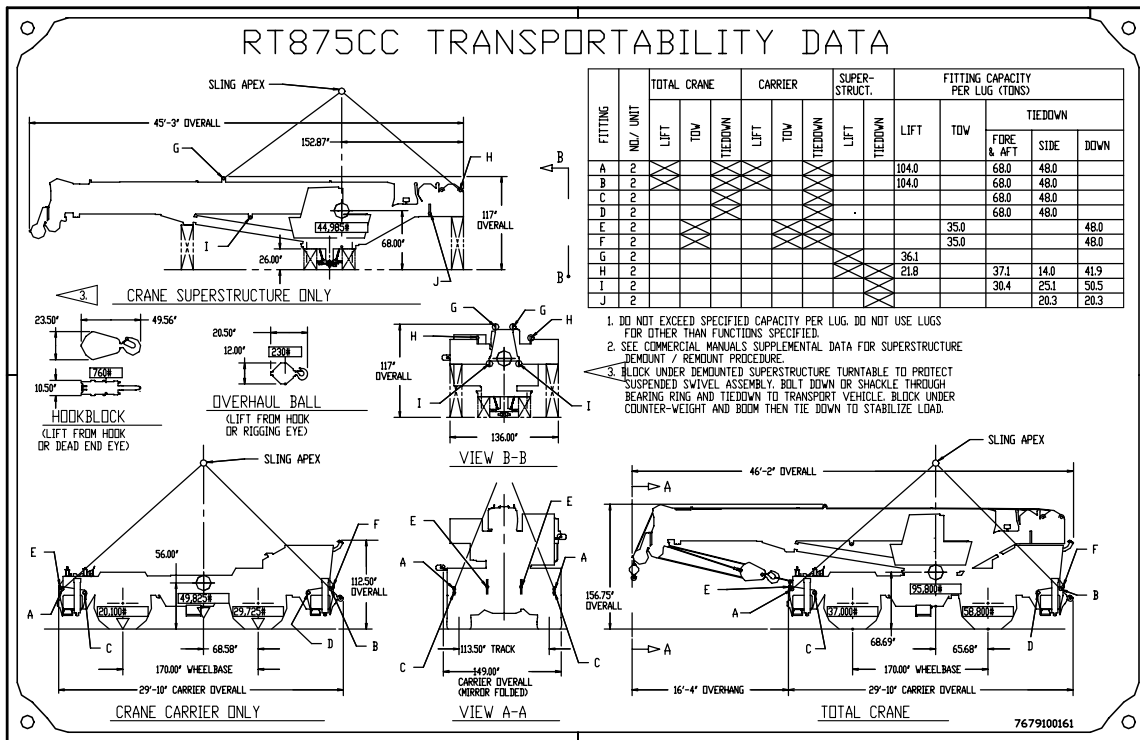

Item No. 8 – Transportability Data

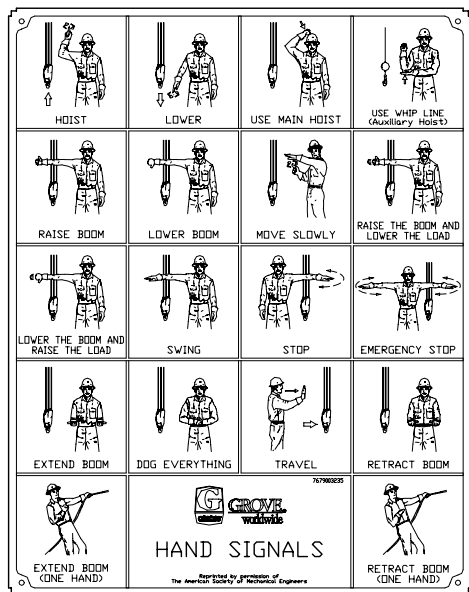

Item No. 9 – Hand Signals

⚠ CAUTION

1. DO NOT REMOVE TRANSMISSION DIPSTICK UNLESS ENGINE IS RUNNING WITH TRANSMISSION IN NEUTRAL (STATIC OIL LEVEL MAY BE ABOVE FILL PIPE).
2. CHECK OIL LEVEL WITH ENGINE RUNNING, TRANSMISSION IN NEUTRAL AND TRANSMISSION OIL TEMPERATURE STABILIZED AT 180°-200° F.
3. IF NECESSARY, ADD TRANSMISSION OIL THROUGH DIPSTICK/FILL TUBE, TO APPROPRIATE LEVEL.
4. REPLACE DIPSTICK SECURELY.

7679100110

Item No. 10 – Caution When Checking Transmission Oil



Item No. 11 – Caution Hearing Protection Required



Item No. 12 – Danger Rotating Fan

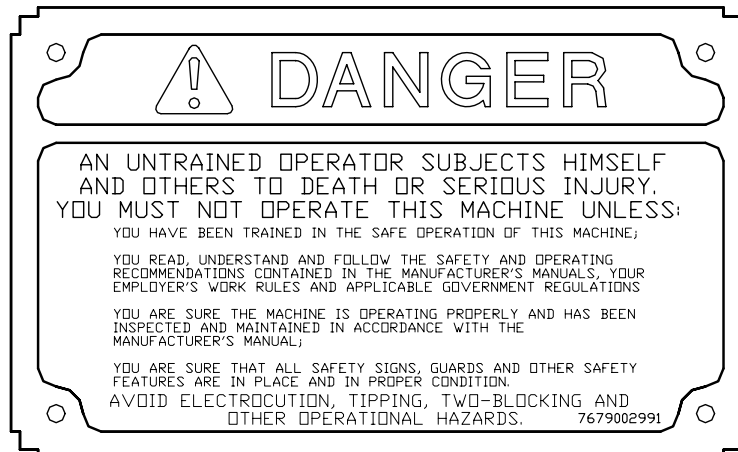

Item No. 13 – Danger Untrained Operator

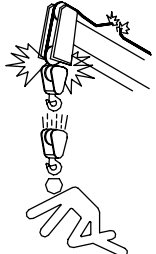
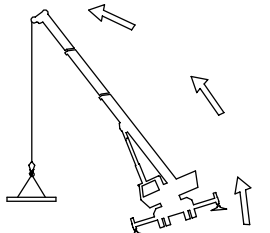
	<p>! DANGER</p>	<p>! CAUTION</p>
<p>DO NOT PASS LOADS OR BOOM OVER GROUND PERSONNEL.</p>	<p>TWO-BLOCKING HAZARD</p> <ul style="list-style-type: none"> TO AVOID DEATH OR SERIOUS INJURY, KEEP LOAD HANDLING DEVICES AWAY FROM BOOM TIP WHEN EXTENDING OR LOWERING THE BOOM AND WHEN HOISTING UP. THIS CRANE SHOULD HAVE A FUNCTIONAL ANTI-TWO-BLOCK AND CONTROL LOCK-OUT SYSTEM. TEST DAILY FOR PROPER OPERATION. FOLLOW INSTRUCTIONS IN OPERATOR'S AND SAFETY HANDBOOK. 	<p>ELECTRONIC EQUIPMENT ON THIS CRANE IS INTENDED AS AN AID TO THE OPERATOR.</p> <p>UNDER NO CONDITION SHOULD IT BE RELIED UPON TO REPLACE THE USE OF CAPACITY CHARTS AND OPERATING INSTRUCTIONS. SOLE RELIANCE UPON THESE ELECTRONIC AIDS IN PLACE OF GOOD OPERATING PRACTICES CAN CAUSE AN ACCIDENT.</p> <p>DO NOT REMOVE ANY DECAL, THE LOAD CHART, OR THE OPERATOR'S AND SAFETY HANDBOOK FROM THIS CRANE.</p>
	<p>! DANGER</p>	<p>! DANGER</p>
<p>POSITION CRANE ON FIRM SURFACE. EXTEND OUTRIGGERS AND LEVEL CRANE.</p>	<p>TIPPING HAZARD</p> <ul style="list-style-type: none"> TO AVOID DEATH OR SERIOUS INJURY, ENSURE LOAD AND CRANE'S CONFIGURATION ARE WITHIN CAPACITY AS SHOWN ON CRANE'S LOAD RATING CHART AND NOTES. THIS CRANE SHOULD HAVE A FUNCTIONAL LOAD MOMENT INDICATOR AND CONTROL LOCK-OUT SYSTEM. TEST DAILY FOR PROPER OPERATION. FOLLOW INSTRUCTIONS IN OPERATOR'S AND SAFETY HANDBOOK. 	<p>TO AVOID DEATH OR SERIOUS INJURY:</p> <p>NEVER HANDLE PERSONNEL WITH THIS MACHINE WITHOUT WRITTEN APPROVAL FROM GROVE U.S. L.L.C.</p> <p>NEVER USE THIS CRANE FOR BUNGEE JUMPING OR ANY FORM OF AMUSEMENT OR SPORT.</p> <p>NEVER PERMIT ANYONE TO RIDE LOADS, HOOKS, SLINGS OR OTHER RIGGING FOR ANY REASON.</p> <p>NEVER GET ON OR OFF A MOVING CRANE.</p> <p>NEVER ALLOW ANYONE OTHER THAN THE OPERATOR TO BE ON THIS CRANE WHILE THE MACHINE IS OPERATING OR TRAVELING.</p> <p>FOLLOW INSTRUCTIONS IN OPERATOR'S AND SAFETY HANDBOOK.</p> <p>7679002988</p>

Item No.14 – Danger Two Blocking/Tipping Hazard

HEATER FUEL TANK

SEE OPERATOR'S MANUAL FOR FUEL REQUIREMENTS

7679003014

Item No. 15 – Heater Fuel Tank

! DANGER

PROPER CABLE WEDGE MUST BE USED FOR ATTACHING WIRE ROPE TO GROVE HOIST DRUMS. BE SURE WEDGE MARKING MATCHES HOIST MODEL AND THE CABLE DIAMETER BEING INSTALLED. INJURY MAY RESULT IF INCORRECT WEDGE IS USED.

7679003002

Item No. 16 – Danger Proper Wedge Socket

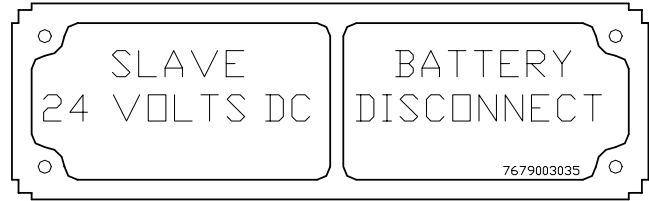
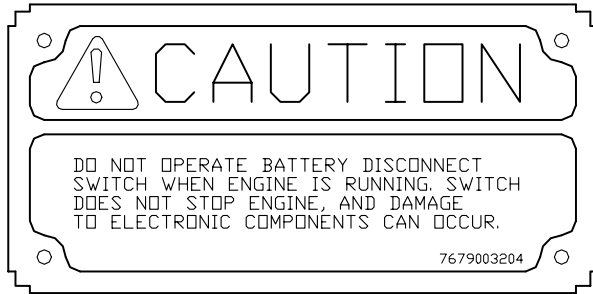

Item No. 18 – Slave/Battery Disconnect

Item No. 17 – Damage Disconnect Switch

! DANGER

EMERGENCY STOWAGE AND RECOVERY
FAILURE TO FOLLOW PROCEDURES COULD RESULT IN DEATH OR SERIOUS INJURY.

PREPARATIONS:

- Open APU control box. Verify that APU power switch is turned off, and Crane/Front Steer switch is in 'crane' position.
- If crane's own electrical power is compromised, connect a NATO slave electrical cable between slave receptacle and another vehicle having 24 VDC electrical system with a compatible receptacle.
- Verify that Battery Disconnect switch is in 'engaged' position.

OPERATION (select steps according to need):

TAKE HEED: Depending on failure mode, LMI may not be operational; do not extend or lower boom when lowering load. Operate only one function at a time.

NOTE: To conserve electrical power, turn off APU when not operating a function.

- Place the crane ignition switch in its 'on' position.

NOTE: It will be necessary to shift the diverter valves controls to the function(s) to be operated, i.e. hoist(s), boom lift/telescope and rear axle steering, swing and outriggers, according to diverter valves labeling.

- Turn on APU, and using swing, telescope and/or hoist functions as appropriate, lower any hook load to ground, and detach.

NOTE: Depending on failure mode, it may be necessary to actuate LMI by-pass to perform certain functions.

- Retract boom, using hoist to keep hook block off ground.
- Swing boom to front of crane, and use boom lift and hoist functions as appropriate to secure hook block to front storage loop.
- Lower boom to horizontal, keeping hoist cable snug, and engage swing lock.
- Retract outrigger stabilizers, and then the beams.
- Remove and stow outrigger pads.

NOTE: If crane cannot be driven (i.e. engine does not run, or front axle steering system is not operational), proceed as follows:

- Set diverter valves controls as appropriate, and straighten rear wheels.
- Turn 'Crane/Front Steer' switch to 'Front Steer' position, and straighten front wheels.
- Connect tow bar of recovery vehicle, or winch cable of recovery trailer, to crane rear towing lugs.

NOTE: Maximum towing speed is 2 mph (6 km/hr) for a maximum towing distance of 6 miles (10km).

- If crane is to be towed, connect safety chains from recovery vehicle to crane rear tiedown lugs.
- Ensure transmission is in neutral and hydraulic pump is disengaged.
- If recovery vehicle has 140 psi max (827 kpa) auxiliary air supply, connect at 'Aux Air In' connection at rear of crane, and inflate crane air system.
- Release crane parking brake, or cage all front and rear spring brake chamber springs if no auxiliary air is available.

NOTE: Turn off the crane and APU power switches when moving. Stop all movement when adjusting steering for turning maneuvers. Either front or rear steering may be used (set 'Crane/Front Steer' switch and diverter valves appropriately).

- Tow or winch the crane accordingly.
- Turn off APU power switch, return 'Crane/Front Steer' switch to 'Crane' position.

For complete instructions, see Operator's and Maintenance Manuals.

APU CONTROL BOX AND DIVERTER VALVES

CAR ACCESS STEPS

SLAVE RECEPTACLE

BATTERY DISCONNECT

LEFT REAR TIRE/WHEEL

7679100151

Item No. 19 – Emergency Stowage Procedures

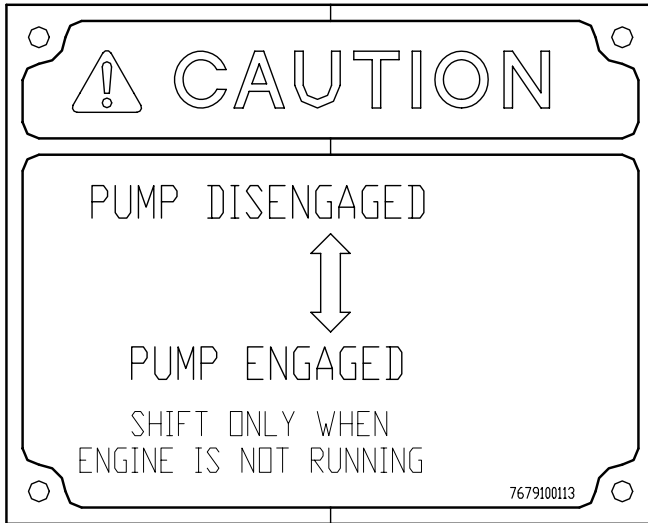

Item No. 20 – Pump Disconnect

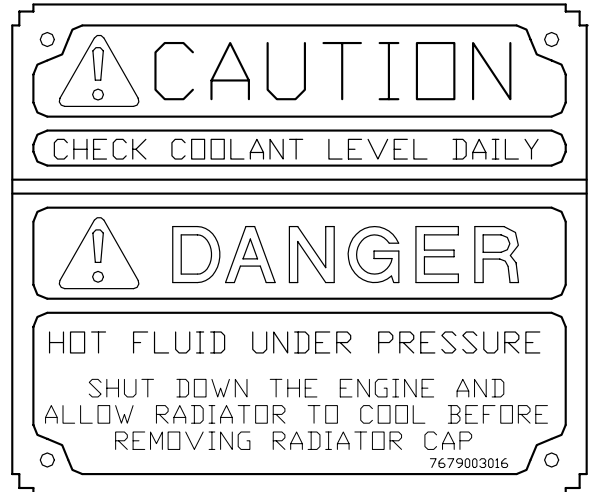

Item No. 21. – Danger Hot Coolant

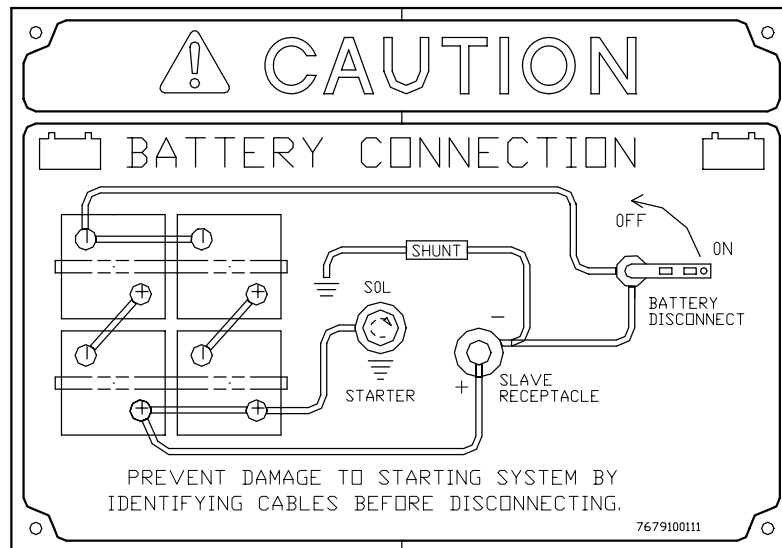

Item No. 22 – Battery Connection Diagram

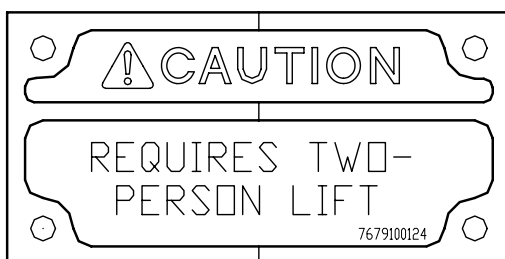

Item No. 23 – Floats are a Two-Person Lift

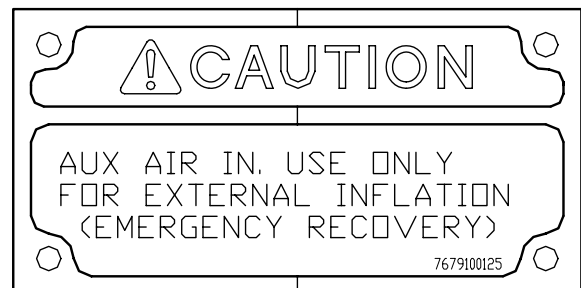

Item No. 24 – Auxiliary Air In Connection

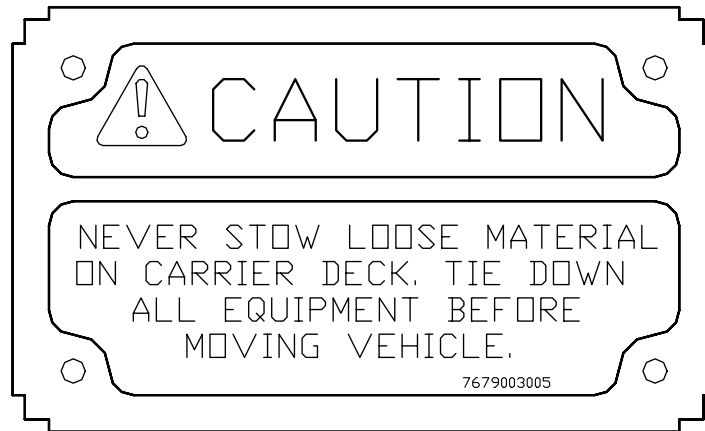

Item No. 25 – Caution Loose Material Stowage

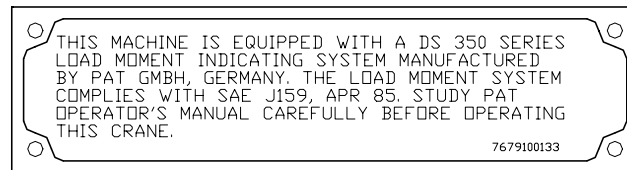

Item No. 26 – LMI System ID



Item No. 27 – Emergency Exit

RATED LIFTING CAPACITIES IN POUNDS 34 FT. - 60 FT. BOOM

RADIUS IN FEET	ON OUTRIGGERS, ALL BEAMS FULLY EXTENDED - 360° #9001					
	MAIN BOOM LENGTH IN FEET					
	34	40	45	50	55	60
10	80,000 (65)	80,000 (68.5)	80,000 (71.5)	80,000 (73.5)	80,000 (75)	80,000 (76.5)
12	80,000 (61)	80,000 (65.5)	80,000 (67)	80,000 (67.5)	80,000 (73)	80,000 (74.5)
15	80,000 (55)	80,000 (61.5)	80,000 (64.5)	80,000 (67)	80,000 (68.5)	79,000 (71.5)
20	80,000 (43.5)	80,000 (52)	80,000 (57)	80,000 (60.5)	75,000 (64)	70,000 (66.5)
22	73,000 (38.5)	73,000 (48)	73,000 (53.5)	73,000 (58)	70,000 (63.5)	65,000 (64.5)
25	62,000 (30)	62,000 (41.5)	62,000 (48.5)	62,000 (53.5)	60,000 (57.5)	58,000 (61)
30		50,000 (28.5)	50,000 (39)	50,000 (46)	50,000 (51)	48,000 (55.5)
31			48,000 (37)	48,000 (44.5)	48,000 (50)	44,000 (54)
35			39,500 (27)	39,500 (37)	39,500 (44)	39,500 (49.5)
40				31,600 (25.5)	31,600 (33.5)	31,600 (42.5)
45					25,800 (24.5)	25,800 (34.5)
50						21,500 (24.5)
MINIMUM BOOM ANGLE (DEG) FOR INDICATED LENGTH (NO LOAD)						0
MAXIMUM BOOM LENGTH (FT.) AT 0 DEG. BOOM ANGLE (NO LOAD)						60
() INDICATES REFERENCE BOOM ANGLE IN DEGREES						A6-829-00881B

#XXXX INDICATES LMI OPERATING CODE; SEE OPERATOR'S MANUAL FOR INSTRUCTIONS

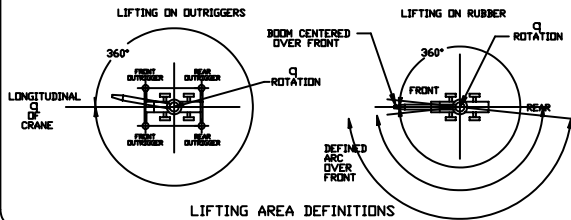

RADIUS IN FEET	ON-RUBBER CAPACITIES		
	STATIONARY CAPACITY #9005	STATIONARY CAPACITY #9005	PICK AND CARRY CAP. UP TO 2.5 MPH #9006
	DEFINED ARC OVER FRONT	360°	BOOM CENTERED OVER FRONT
10	72,000 (a)	56,400 (e)	69,700 (a)
12	64,100 (a)	46,850 (f)	60,600 (b)
15	54,000 (a)	36,900 (f)	50,200 (d)
20	43,450 (a)	23,650 (f)	38,200 (d)
25	35,700 (c)	16,750 (f)	30,100 (f)
30	26,100 (d)	12,500 (f)	22,150 (f)
35	20,100 (e)	9,480 (f)	18,500 (f)
40	16,000 (f)		15,600 (f)
45	13,000 (f)		13,000 (f)
50	10,700 (f)		10,700 (f)

MAX. PERMISSIBLE BOOM LENGTHS:
 (a) 34 ft. (b) 40 ft. (c) 45 ft.
 (d) 50 ft. (e) 55 ft. (f) 60 ft.

A6-829-00882C

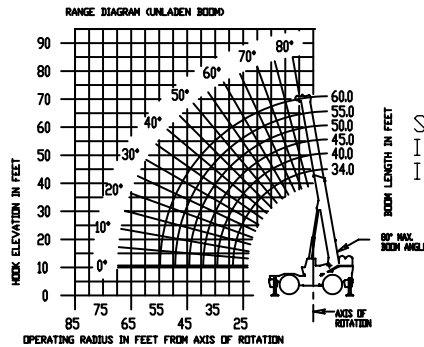

Item No. 28 – Load Chart – Lifting Radius and Capacities

GENERAL:

- Rated loads as shown on capacity charts pertain to this machine as originally manufactured and equipped. Modifications to the machine or use of optional equipment other than that specified can result in a reduction of capacity.
 - Capacities appearing above the bold lines are based on structural strength, and tipping should not be relied upon as a capacity limitation.
 - Construction equipment can be hazardous if improperly operated or maintained. Operation and maintenance of this machine shall be in compliance with the information contained in the various Technical Manuals (TMs) supplied with this machine. If these manuals are missing, obtain replacements immediately.
 - The operator and other personnel associated with machine shall acquaint themselves fully with the latest American National Safety Standards (ANSI/ASME) for cranes.
- SET UP:
- The machine shall be level and on a firm supporting surface. Depending on the nature of the supporting surface, it may be necessary to place structural supports under the outrigger floats or tires to spread the load to a larger bearing surface.
 - For outrigger operation, outrigger beams shall be fully extended and tires raised free of all crane weight before operating the boom or lifting loads.
 - Before lifting on rubber, tires shall be inflated to the specified pressure, and rear axle oscillation lockouts shall be functioning correctly. Verify correct operation of the lockout system according to procedures identified in the operator's manual.

OPERATION:

- Rated loads at rated radius shall not be exceeded. Do not tip the machine to determine allowable loads.
- All rated loads have been tested to and meet minimum requirements of SAE J1063 - Cantilevered Boom Crane Structures - Method of Test. Rated loads do not exceed 85% of the tipping load (on-outrigger capacities) or 75% of the tipping load (on-rubber capacities) as determined by SAE J165 Crane Stability Test Code.
- Rated loads shown are net loads which may be suspended freely from the hookblock when the crane is equipped with a Grove-furnished lifting device (i.e. Grove 40 ton, 2-sheave hook block weighing 760 lbs., or Grove 3 ton overall ball weighing 230 lbs.) and with auxiliary boom nose installed. If other lifting devices are used, and/or if additional devices are used below the hook, the additional weight of those devices shall be considered part of the load to be lifted.
- When more than the minimum required hoist reeving is used, the additional rope weight shall be considered part of the load to be lifted.
- Rated loads are for lift crane service only.
- When boom length and/or lift radius are between values listed, the smallest load shown at either the next larger radius or the next longer or shorter boom length shall be used.
- Load ratings are based on freely suspended loads. No attempt shall be made to have a load horizontally in any direction while on the ground or on any supporting surface.
- On-rubber capacities are applicable only with machine on firm level surface.
- On-rubber capacities are applicable only when crane is equipped with general 29.5-25 ND LCH or MCS E-3 28 PR bias-ply tires, or Michelin 29.5R25 HR One-star Rating radial tires, inflated to 75 psi cold inflation pressure.

- All on-rubber lifting depends on proper tire inflation and condition. Capacities must be reduced for lower tire inflation pressure. Damaged tires are hazardous to safe operation of crane.
- For pick-and-carry operation, boom must be centered over front of machine, mechanical swing lock engaged, and load restrained from swinging. When handling loads in the structural range with capacities close to maximum ratings, travel must be reduced to creep speeds.
- Do not operate at a radius or boom length where capacities are not listed. At these positions, the machine may overturn without any load on the hook.
- The boom angle before loading should be greater than the reference boom angle, to allow for deflection.
- Keep load handling devices a minimum of 42 inches (107 cm) below boom head at all times.
- Do not lift loads when boom is fully lowered. The Load Moment Indicator (LMI) senses pressure and will not provide warnings or lockout. The crane can become overloaded if lift cylinders are fully retracted.
- For safe operation, the user shall make due allowances for the particular job conditions, such as: soft or uneven ground, out-of-level conditions, high winds, side loads, pendulum action, jerking or sudden stopping of loads, experience of personnel, two-machine (tandem) lifts, traveling with loads, electric wires, obstacles, hazardous conditions, etc. Side pull on boom is extremely dangerous.
- Never handle personnel with this machine unless the requirements of the applicable national, state, and local regulations and safety codes are met.
- The maximum in-service wind speed is 20 mph. (32 km/h). It is recommended when wind velocity is above 20 mph. (32 km/h) rated loads and boom lengths shall be reduced appropriately. For machines not in-service, the main boom should be retracted and lowered with the swing brake set when wind velocities are over 30 mph. (48 km/h).
- The maximum load which can be telescoped is not definable because of variations in loadings and crane maintenance, but it is safe to attempt retraction and extension of the boom with load within the limits of the capacity charts.

DEFINITIONS:

- Operating Radius:** Horizontal distance from a projection of the axis of rotation to the supporting surface before loading to the center of the vertical hoist line or tackle with load applied.
- Reference Boom Angle:** (Shown in parentheses on main boom capacity chart) is the angle between the boom base section and the horizontal, after lifting the rated load at the rated radius with the rated boom length.
- Working Area:** Areas measured in a circular arc about the center line of rotation as shown on the lifting area diagrams.
- Freely Suspended Load:** Load hanging free with no direct external force applied except by the hoist cable.
- Side Load:** Horizontal force applied to the lifted load either on the ground or in the air.
- Defined Arc Over Front:** Includes 6° on either side of longitudinal centerline of machine.
- Creep:** not over 200 ft. of movement in any 30 min. period, and not exceeding 1 mph.

7679100150

Item No. 29 – Load Chart - Notes

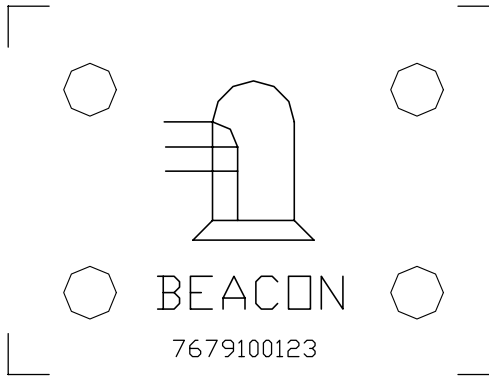

Item No. 30 - Beacon

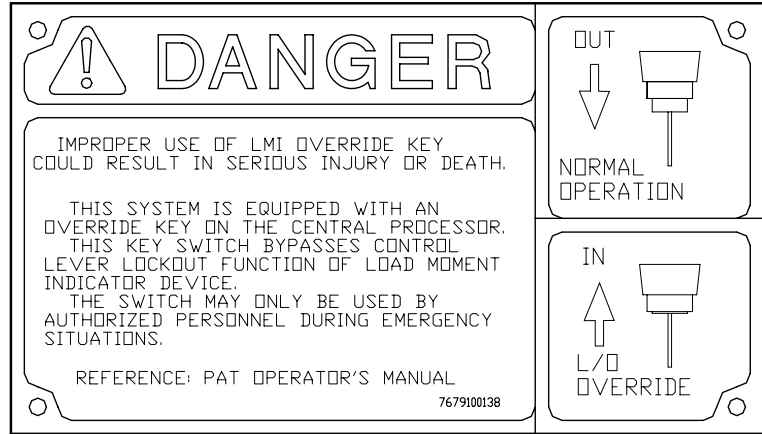

Item No 31 – Danger LMI Override Key



Item No. 32 – Hearing Protection Required

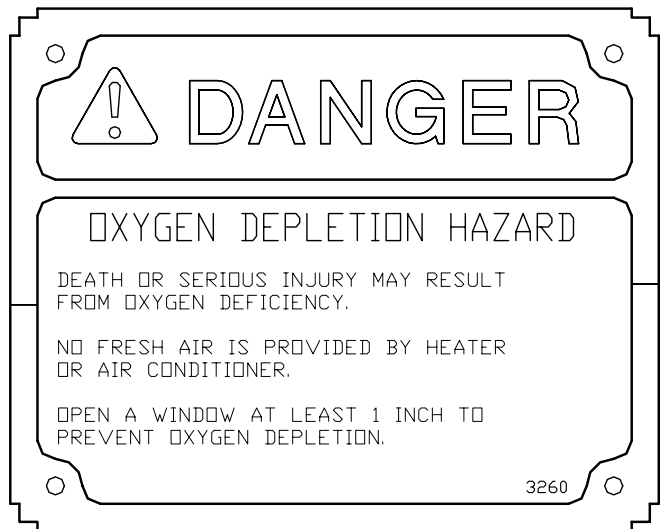

Item No. 33 – Hazard Oxygen Depletion

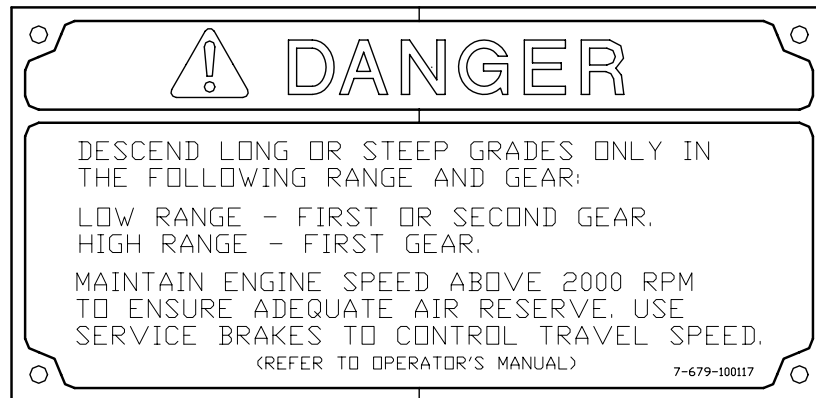

Item No. 34 – Danger Steep Grades

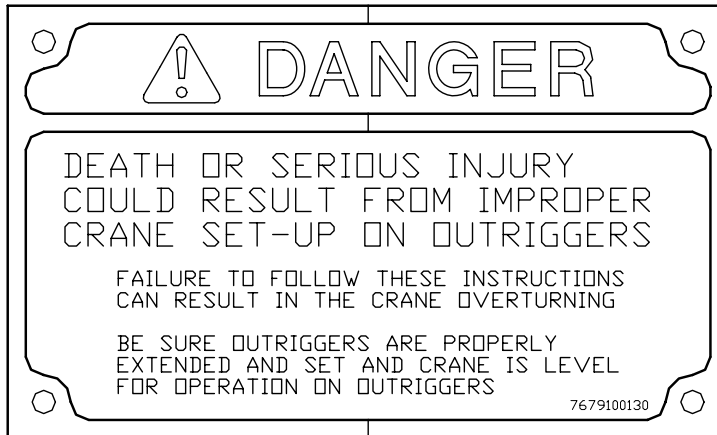

Item No. 35 – Danger Improper Outrigger Setup

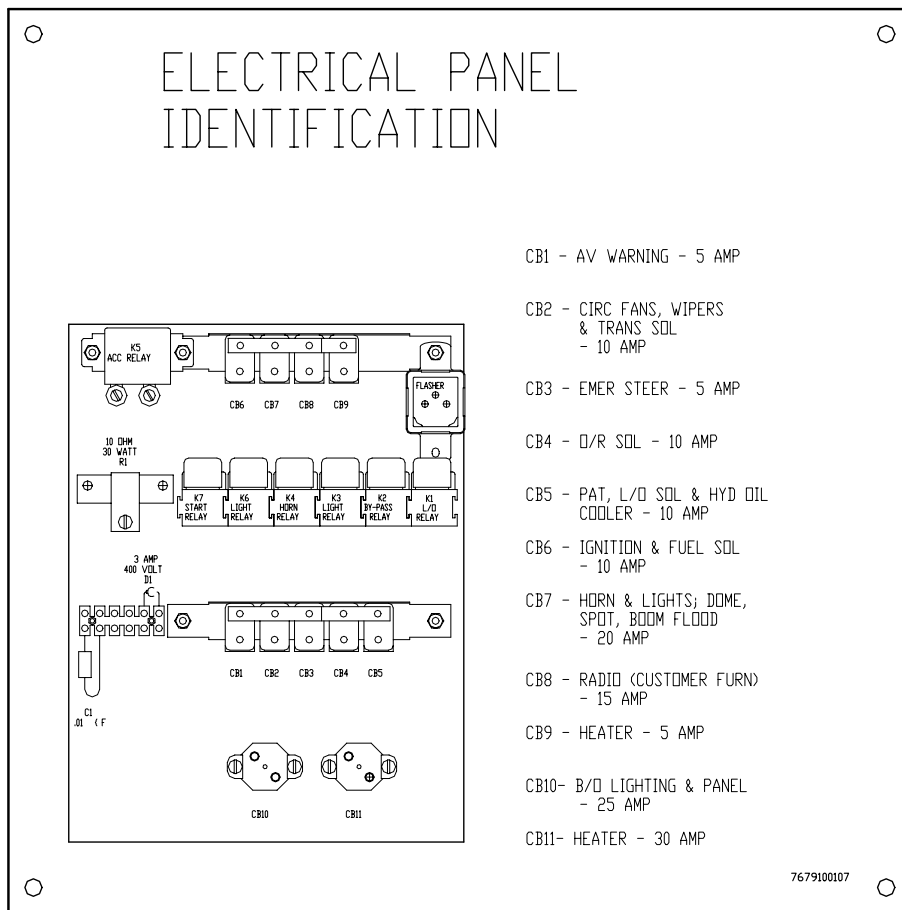

Item No. 36 – Electrical Panel Identification

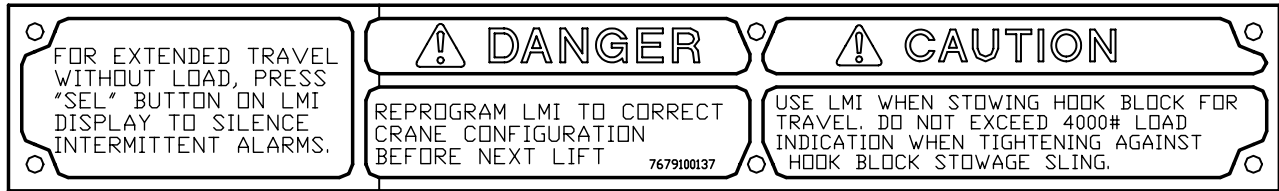

Item No. 37 – Danger Improper LMI Setup/Use

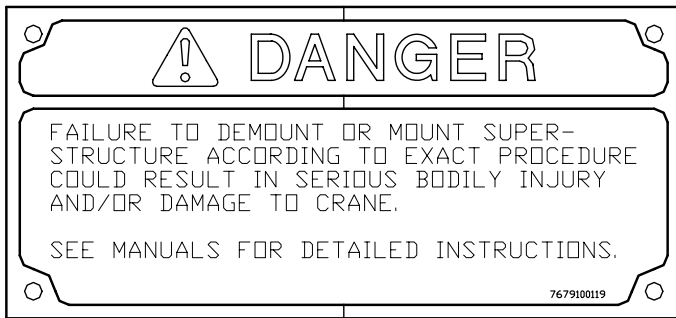

Item No. 38 – Danger Demount Superstructure

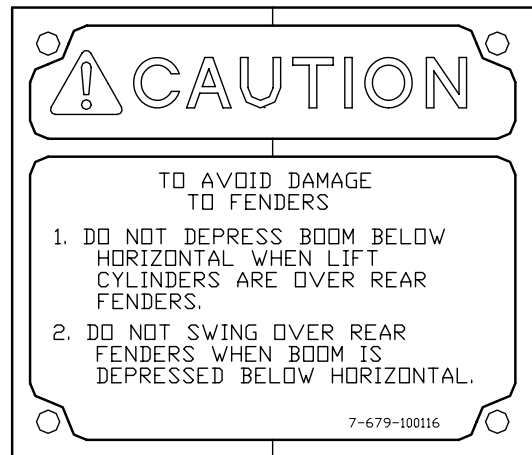

Item No. 39 – Caution Fender Damage

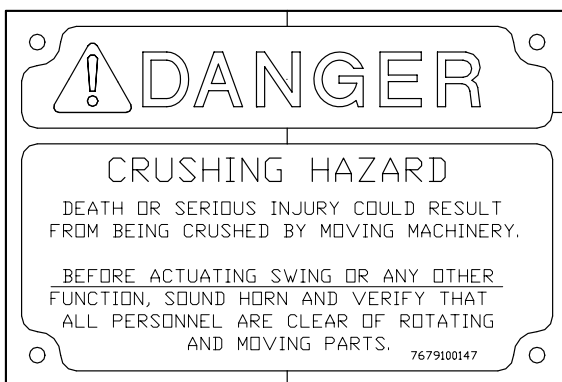

Item No. 40 – Danger Crushing Hazard

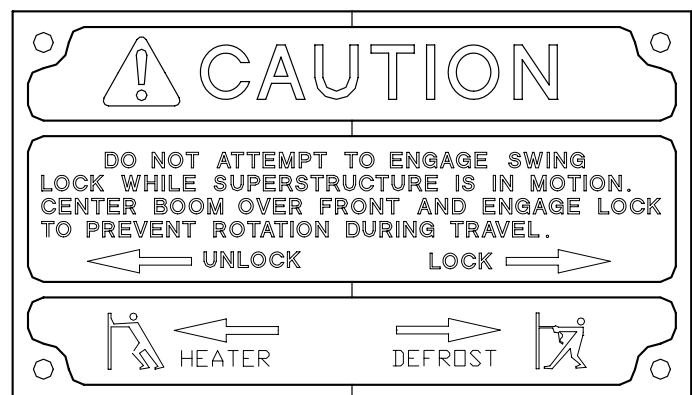

Item No. 41 – Caution Do Not Engage Swing Lock

**APPENDIX F
LOAD CHART (RT875CC)
RT875CC 34'-60' BOOM 85% LIFTING CAPACITIES
(POUNDS) ON OUTRIGGERS – 360°**

Radius in Feet	Main Boom Length in Feet					
	34	40	45	50	55	60
10	80,000 (65)	80,000 (68.5)	80,000 (71.5)	80,000 (73.5)	80,000 (75)	80,000 (76.5)
12	80,000 (61)	80,000 (65.5)	80,000 (68.5)	80,000 (71)	80,000 (73)	80,000 (74.5)
15	80,000 (55)	80,000 (60.5)	80,000 (64.5)	80,000 (67)	80,000 (69.5)	79,000 (71.5)
20	80,000 (43.5)	80,000 (52)	80,000 (57)	80,000 (60.5)	75,000 (64)	70,000 (66.5)
22	73,000 (38.5)	73,000 (48)	73,000 (53.5)	73,000 (58)	70,000 (61.5)	65,000 (64.5)
25	62,200 (30)	62,200 (41.5)	62,200 (48.5)	62,200 (53.5)	60,000 (57.5)	58,000 (61)
30		50,000 (28.5)	50,000 (39)	50,000 (46)	50,000 (51)	48,000 (55.5)
31			48,000 (37)	48,000 (44.5)	48,000 (50)	44,000 (54)
35			39,500 (27)	39,500 (37)	39,500 (44)	39,500 (49.5)
40				31,600 (25.5)	31,600 (35.5)	31,600 (42.5)
45					25,800 (24.5)	25,800 (34.5)
50						21,500 (24.5)

NOTE: Boom angles are in degrees.

LOAD CHART (RT875CC) (Contd)

RT875CC 34'-60' BOOM LIFTING CAPACITY NOTES

GENERAL:

1. Rated loads as shown on lift chart pertain to this machine as originally manufactured and equipped. Modifications to the machine or use of optional equipment other than that specified can result in a reduction of capacity.
2. Construction equipment can be hazardous if improperly operated or maintained. Operation and maintenance of this machine shall be in compliance with the information in this manual.
3. The operator and other personnel associated with machine shall fully acquaint themselves with the safety standards set forth in this manual.

SETUP:

1. The machine shall be leveled on a firm supporting surface. Depending on the nature of the supporting surface, it may be necessary to have structural supports under the outrigger floats or tires to spread the load to a larger bearing surface.
2. For outrigger operation, outriggers shall be fully extended with tires raised free of crane weight before operating the boom or lifting loads.
3. Tires shall be inflated to the recommended pressure before lifting on rubber.

OPERATION:

1. Rated loads at rated radius shall not be exceeded. Do not tip the machine to determine allowable loads.
2. All rated loads have been tested to and meet minimum requirements of SAE J1063 OCT80 - Cantilevered Boom Crane Structures - Method of Test, and do not exceed 85% of the tipping load on outriggers as determined by SAE J765 OCT80 Crane Stability Test Code.
3. Rated loads apply to loads on hook for machines equipped with originally furnished hookblock, auxiliary boom nose and overhaul ball.
4. Load ratings are based on freely suspended loads. No attempt shall be made to move a load horizontally on the ground in any direction.
5. Rated loads do not account for wind on lifted load or boom. It is recommended when wind velocity is above 20 mph (32km/h), rated loads and boom lengths shall be appropriately reduced.

LOAD CHART RT875CC (Cont'd)

6. Rated loads are for lift crane service only.
7. Do not operate at a radius or boom length where capacities are not listed. At these positions, the machine may overturn without any load on the hook.
8. The maximum load which can be telescoped is not definable because of variations in loadings and crane maintenance, but it is safe to attempt retraction and extension within the limits of the capacity chart.
9. When either boom length or radius or both are between values listed, the smallest load shown at either the next larger radius or boom length shall be used.
10. For safe operation, the user shall make due allowances for his particular job conditions, such as: soft or uneven ground, out of level conditions, high winds, side loads, pendulum action, jerking or sudden stopping of loads, hazardous conditions, experience of personnel, two machine lifts, traveling with loads, electric wires, etc. Side pull on boom is extremely dangerous.
11. Handling of personnel from the boom is not authorized except with equipment furnished and installed by Grove Manufacturing Company.
12. Keep load handling devices a minimum of 18 inches (45.7 cm) below boom head at all times.
13. The boom angle before loading should be greater than the loaded boom angle to account for deflection.
14. Capacities appearing above the bold line are based on structural strength and tipping should not be relied upon as a capacity limitation.
15. The LMI is calibrated to include originally furnished hookblock, auxiliary boom nose and overhaul ball as an integral part of the machine.
16. Load indicating device meets SAE J376 Section 4.2 accuracy requirements for loads on hook from 9,000 to 80,000 pounds.

DEFINITIONS:

1. **Operating Radius:** Horizontal distance from a projection of the axis of rotation to the center of the vertical hoist line or tackle with load applied.
2. **Loaded Boom Angle (Shown in Parenthesis on Main Boom Capacity Chart):** is the angle between the boom base section and the horizontal, after lifting the rated load at the rated radius with the rated boom length.

LOAD CHART –RT875CC (Cont'd)

3. **Working Area:** Areas measured in a circular arc about the center line of rotation as shown on the working area diagram.
4. **Freely Suspended Load:** Load hanging free with no direct external force applied except by the lift cable.
5. **Side Load:** Horizontal force applied to the lifted load either on the ground or in the air.

Radius in Feet	Stationary Capacity Defined Arc (3) Over Front	Stationary Capacity 360 Degree Arc	Pick & Carry Cap. Up to 2.5 MPH Boom Centered (7) Over Front
10	72,000 (a)	56,400 (e)	69,700 (a)
12	64,100 (a)	46,850 (f)	60,600 (b)
15	54,000 (a)	36,900 (f)	50,200 (d)
20	43,450 (a)	23,650 (f)	38,200 (d)
25	35,700 (c)	16,750 (f)	30,100 (f)
30	26,100 (d)	12,500 (f)	22,150 (f)
35	20,100 (e)	9,480 (f)	18,500 (f)
40	16,000 (f)		15,600 (f)
45	13,000 (f)		13,000 (f)
50	10,700 (f)		10,700 (f)

LOAD CHART RT875CC (Cont'd)

Maximum Permissible Boom Lengths:

- (a) 34 ft. (d) 50 ft.
- (b) 40 ft. (e) 55 ft.
- (c) 45 ft. (f) 60 ft.

	No Load Stability Data	Main Boom 60 ft.
Front	Min. boom angle (deg.) for indicated length	0
(No load)	Max. boom length (ft.) at 0 deg. boom angle	60
360 Deg.	Min. boom angle (deg.) for indicated length	0
(No load)	Max. boom length (ft.) at 0 deg. boom angle	60

1. Capacities are in pounds and do not exceed 75% of tipping loads as determined by test in accordance with SAE J765 OCT80.
2. Capacities are applicable to machines equipped with 29.5 x 25 (28 PR) bias ply tires, at 75 psi cold inflation pressure.
3. Defined Arc - Over front includes 6' on either side of longitudinal centerline of machine.
4. Capacities are applicable only with machine on firm level surface.
5. Rear axle lockout valve must be functioning properly before lifting on rubber. Refer to TM5-3810-306-20.
6. All rubber lifting depends on proper tire inflation and condition. Capacities must be reduced for lower tire inflation pressures. Damaged tires are hazardous to safe operation of crane.
7. For pick and carry operation, boom must be centered over front of machine, mechanical swing lock engaged and load restrained from swinging. when handling loads in the structural range with capacities close to maximum ratings, travel must be reduced to creep speeds.
8. Creep-not over 200 ft. of movement in any 30 min. period and not exceeding 1 mph.

LOAD CHART RT875CC (Cont'd)

RANGE DIAGRAM (UNLADEN BOOM)

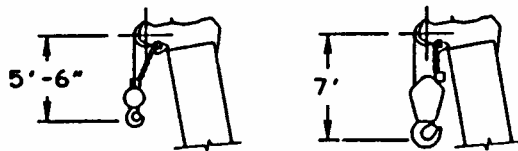
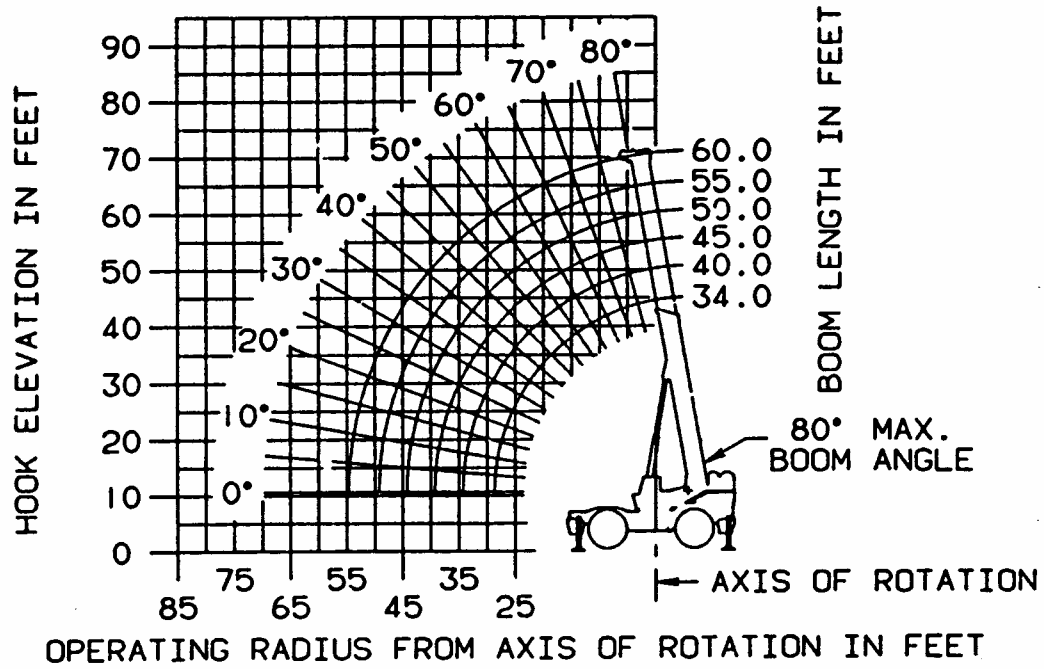

DIMENSIONS ARE FOR LARGEST FURNISHED HOOK BLOCK AND OVERHAUL BALL, WITH ANTI-TWO BLOCK ACTIVATED.

APPENDIX F

LOAD CHART (RT875CCS)

**RT875CCS 34'-60' BOOM 85% LIFTING CAPACITIES
(POUNDS) ON OUTRIGGERS - 360°**

RADIUS IN FEET	ON OUTRIGGERS, ALL BEAMS FULLY EXTENDED - 360° #9001					
	MAIN BOOM LENGTH IN FEET					
	34	40	45	50	55	60
10	80,000 (65)	80,000 (68.5)	80,000 (71.5)	80,000 (73.5)	80,000 (75)	80,000 (76.5)
12	80,000 (61)	80,000 (65.5)	80,000 (68.5)	80,000 (71)	80,000 (73)	80,000 (74.5)
15	80,000 (55)	80,000 (60.5)	80,000 (64.5)	80,000 (67)	80,000 (69.5)	79,000 (71.5)
20	80,000 (43.5)	80,000 (52)	80,000 (57)	80,000 (60.5)	75,000 (64)	70,000 (66.5)
22	73,000 (38.5)	73,000 (48)	73,000 (53.5)	73,000 (58)	70,000 (61.5)	65,000 (64.5)
25	62,200 (30)	62,200 (41.5)	62,200 (48.5)	62,200 (53.5)	60,000 (57.5)	58,000 (61)
30		50,000 (28.5)	50,000 (39)	50,000 (46)	50,000 (51)	48,000 (55.5)
31			48,000 (37)	48,000 (44.5)	48,000 (50)	44,000 (54)
35			39,500 (27)	39,500 (37)	39,500 (44)	39,500 (49.5)
40				31,600 (25.5)	31,600 (35.5)	31,600 (42.5)
45					25,800 (24.5)	25,800 (34.5)
50						21,500 (24.5)
MINIMUM BOOM ANGLE (DEG.) FOR INDICATED LENGTH (NO LOAD)						0
MAXIMUM BOOM LENGTH (FT.) AT 0 DEG. BOOM ANGLE (NO LOAD)						60
< > INDICATES REFERENCE BOOM ANGLE IN DEGREES						A6-829-008831B

#XXXX INDICATES LMI OPERATING CODE: SEE OPERATOR'S MANUAL FOR INSTRUCTIONS

NOTE: Boom angles are in degrees.

ZERO DEGREE BOOM ANGLE CHART

BOOM ANGLE	ON OUTRIGGERS, ALL BEAMS FULLY EXTENDED - 360°					
	MAIN BOOM LENGTH IN FEET					
	34	40	45	50	55	60
0 DEG.	33,350 (28.7)	27,650 (34.2)	23,750 (39.2)	20,600 (44.2)	18,050 (49.2)	15,450 (54.7)
CAPACITIES ARE IN LBS. () INDICATES REFERENCE RADIUS IN FEET.						

LOAD CHART RT875CCS (Cont'd)

NOTES - 34'-60' BOOM LIFTING CAPACITY

GENERAL:

1. Rated loads as shown on capacity charts pertain to this machine as originally manufactured and equipped. Modifications to the machine or use of optional equipment other than that specified can result in a reduction of capacity.
2. Capacities appearing above the bold lines are based on structural strength, and tipping should not be relied upon as capacity limitation.
3. Construction equipment can be hazardous if improperly operated or maintained. Operation and maintenance of this machine shall be in compliance with the information contained in the various technical manuals supplied with this machine. If these manuals are missing, obtain replacements immediately.
4. The operator and other personnel associated with machine shall fully acquaint themselves with the latest American National Safety Standards (ASME/ANSI) for cranes.

SETUP:

1. The machine shall be level and on a firm supporting surface. Depending on the nature of the supporting surface, it may be necessary to have structural supports under the outrigger floats or tires to spread the load to a larger bearing surface.
2. For outrigger operation, outriggers shall be fully extended with tires raised free of crane weight before operating the boom or lifting loads.
3. Tires shall be inflated to the recommended pressure before lifting on rubber. The rear axle oscillation lock-out system shall be functioning correctly. Verify correct operation of the lock-out system according to procedures contained in this manual.

OPERATION:

1. Rated loads at rated radius shall not be exceeded. Do not tip the machine to determine allowable loads.
2. All rated loads shall have been tested to and meet minimum requirements of SAE J1063 - Cantilevered Boom Crane Structures - Method of Test. Rated loads do not exceed 85% of the tipping load (on outriggers) or 75% of the tipping load (on rubber capacities) as determined by SAE J765 Crane Stability Test Code.
3. Rated loads shown are net loads which may be suspended freely from the hookblock when the crane is equipped with a Grove-furnished lifting device (i.e., Grove 40-ton, 3-sheave hookblock weighing 760 lbs, or Grove 5-ton overhaul ball weighing 230 lbs), and with auxiliary boom nose installed. If other lifting devices are used, and/or if additional devices are used below the hook, the additional weight of those devices shall be considered part of the load to be lifted.
4. When more than the minimum required hoist reeving is used, the additional rope weight shall be considered part of the load to be lifted.
5. Rated loads are for lift crane service only.
6. When boom length and/or lift radius are between values listed, the smallest load shown at either the next larger radius or the next longer or shorter boom length shall be used.
7. Load ratings are based on freely suspended loads. No attempt shall be made to move a load horizontally in any direction while on the ground or on any supporting surface.
8. On-rubber capacities are applicable only with machine on firm level surface.

LOAD CHART – RT875CCS (Cont'd)

9. On-rubber capacities are applicable only when crane is equipped with General 29.5-25 ND LCM or MCS E-3 28 PR bias-ply tires or Michelin 29.5R25 XHA One-Star Rating radial tires, inflated to 75 psi cold inflation pressure.
10. All on-rubber lifting depends on proper tire inflation and condition. Capacities must be reduced for lower tire inflation pressure. Damaged tires are hazardous to safe operation of crane.

WARNING

IF NOT REQUIRED TO PERFORM AN ON-RUBBER LIFT, THE BOTTOM LIFT SLING MUST BE REMOVED FROM ITS ON CRANE STOWAGE CRADLE FOR ALL ON RUBBER LIFTS.

11. Because the crane's on-rubber capacity is based on using the maximum axle capacity, the addition of the bottom lift sling to the crane DOES impact the crane's overall on-rubber capacity, including pick and carry capacity. The bottom lift sling MUST be removed from the stowage crane whenever on-rubber lifts are made. If the bottom lift sling is in use for on-rubber handling of containers, it's weight is suspended from the hook and must be considered part of the load being lifted. If the bottom lift sling is not being used for handling of containers, it should be removed from the crane when making on-rubber lifts. Otherwise, it's weight acts to increase the live axle load without that weight being taken into effect through the LMI.
12. For pick and carry operation, boom must be centered over the front of machine, mechanical swing lock engaged, and load restrained from swinging. When handling load in the structural range with capacities close to maximum ratings, travel must be reduced to creep speeds.
13. Do not operate at a radius or boom length where capacities are not listed. At these positions, the machine may overturn without any load on the hook.
14. The boom angle before loading should be greater than the reference boom angle, to account for deflection.
15. Keep load handling devices a minimum of 42 inches (107 cm) below boom head at all times.
16. Do not lift loads when boom is fully lowered. The Load Moment Indicator (LMI) senses pressure and will not provide warnings or lockout. The crane can be overloaded if the lift cylinders are fully retracted.
17. For safe operation, the user shall make due allowances for the particular job conditions, such as: soft or uneven ground, out of level conditions, high winds, side loads, pendulum action, jerking or sudden stopping of loads, experience of personnel, two machine (tandem) lifts, traveling with loads, electric wires, obstacles, hazardous conditions, etc. Side pull on boom is extremely dangerous.
18. Never handle personnel with this machine unless requirements of the applicable national, state, and local regulations and safety codes are met.
19. The maximum in-service wind speed is 20 mph (32 km/h). It is recommended when wind velocity is above 20 mph (32 km/h), rated loads and boom lengths shall be reduced appropriately. For machines not in-service, the main boom should be retracted and lowered with the swing brake set when wind velocities are over 30 mph (48 km/h).
20. The maximum load which can be telescoped is not definable because of variations in loadings and crane maintenance, but it is safe to attempt retraction and extension within the limits of the capacity charts.

DEFINITIONS:

1. Operating Radius: Horizontal distance from a projection of the axis of rotation to the supporting surface before loading to the center of the vertical hoist line or tackle with load applied.
2. Reference Boom Angle (Shown in Parenthesis on Main Boom Capacity Chart): is the angle between the boom base section and the horizontal, after lifting the rated load at the rated radius with the rated boom length.
3. Working Area: Areas measured in a circular arc about the center line of rotation as shown on the lifting area diagrams.
4. Freely Suspended Load: Load hanging free with no direct external force applied except by the hoist cable.
5. Side Load: Horizontal force applied to the lifted load either on the ground or in the air.
6. Defined Arc: Over front includes 6° on either side of longitudinal centerline of machine.
7. Creep: Not over 200 ft (61 m) of movement in any 30-minute period, and not exceeding 1 mph (1.6 km/h).

**RT875CCS 34'-60' BOOM 75% LIFTING CAPACITIES
ON RUBBER (POUNDS) 29.5 x 25 (28 PLY) TIRES**

ON-RUBBER CAPACITIES			
RADIUS IN FEET	STATIONARY CAPACITY #9005	STATIONARY CAPACITY #9005	PICK AND CARRY CAP. UP TO 2.5 MPH #9006
	DEFINED ARC OVER FRONT	360°	BOOM CENTERED OVER FRONT
10	72,000 (a)	56,400 (e)	69,700 (a)
12	64,100 (a)	46,850 (f)	60,600 (b)
15	54,000 (a)	36,900 (f)	50,200 (d)
20	43,450 (a)	23,650 (f)	38,200 (d)
25	35,700 (c)	16,750 (f)	30,100 (f)
30	26,100 (d)	12,500 (f)	22,150 (f)
35	20,100 (e)	9,480 (f)	18,500 (f)
40	16,000 (f)		15,600 (f)
45	13,000 (f)		13,000 (f)
50	10,700 (f)		10,700 (f)
MAX. PERMISSIBLE BOOM LENGTHS: (a) 34 ft. (b) 40 ft. (c) 45 ft. (d) 50 ft. (e) 55 ft. (f) 60 ft.			
A6-829-008832			

RANGE DIAGRAM (UNLADEN BOOM)

NOTES TO ON-RUBBER CAPACITIES

MAIN BOOM 60 FEET		
FRONT	MINIMUM BOOM ANGLE (DEG.) FOR INDICATED LENGTH (NO LOAD)	0
	MAXIMUM BOOM LENGTH (FT) FOR 0 DEG. BOOM ANGLE (NO LOAD)	60
360 DEG.	MINIMUM BOOM ANGLE (DEG.) FOR INDICATED LENGTH (NO LOAD)	0
	MAXIMUM BOOM LENGTH (FT) FOR 0 DEG. BOOM ANGLE (NO LOAD)	60
ON-RUBBER CAPACITIES ARE VALID ONLY FOR GENERAL 29.5-25 28 PR E-3 ND LCM OR MCS TIRES INFLATED TO 75 PSI COLD INFLATION PRESSURE.		

LOAD CHART – RT875CCS (Cont'd)

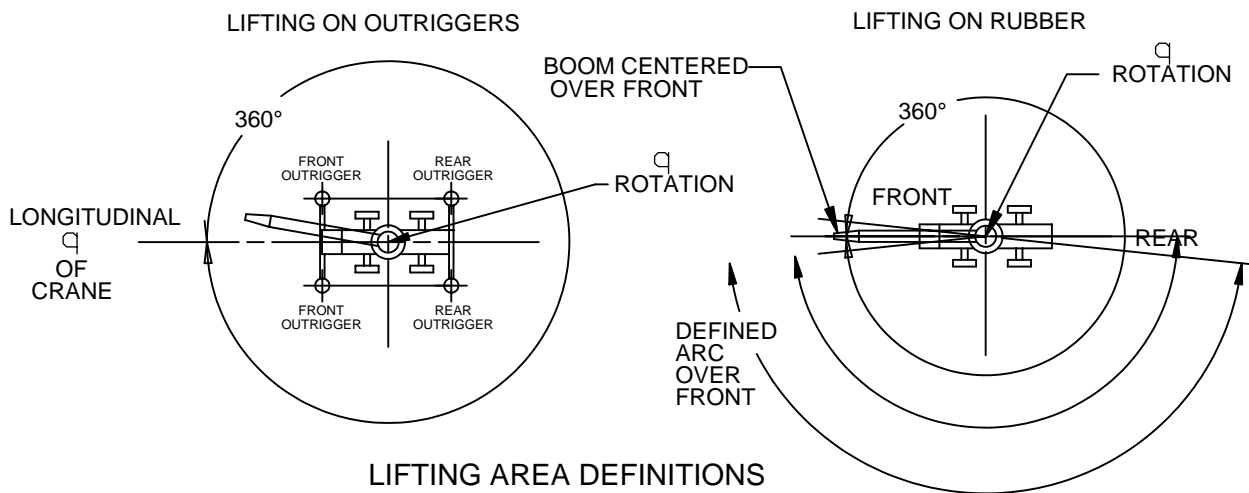
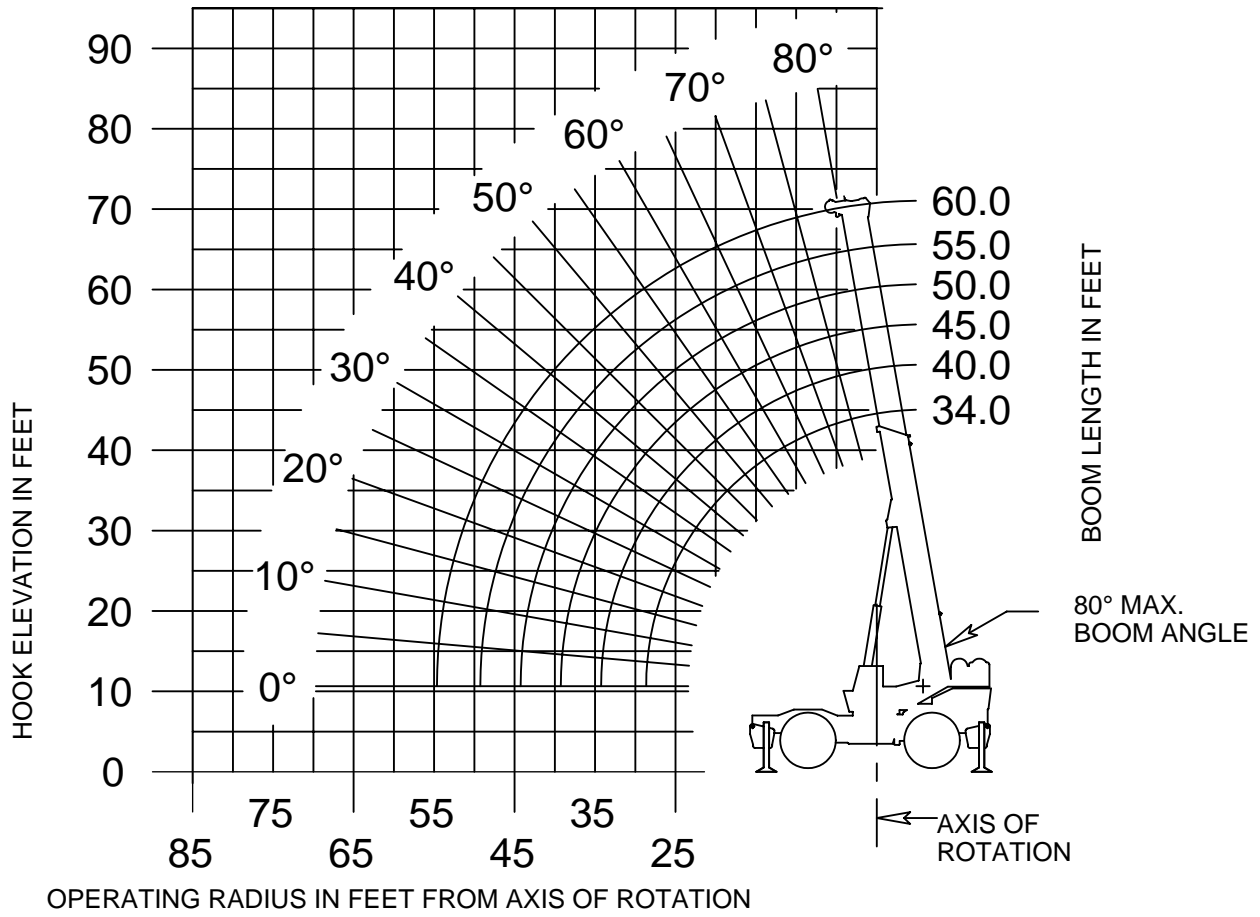

LOAD CHART – RT875CCS (Cont'd)

RT875CCS HOISTING LIMITS

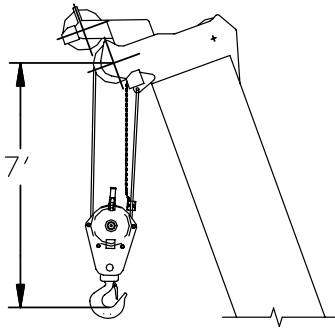

3-SHEAVE HOOK BLOCK

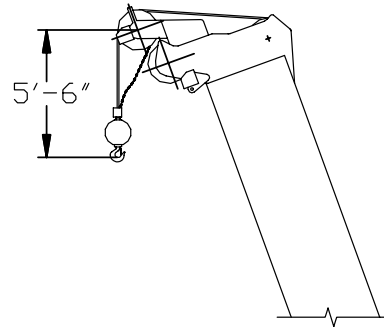

5-TON OVERHAUL BALL

DIMENSIONS ARE FOR GROVE-FURNISHED COMPONENTS,
WITH ANTI-TWO BLOCK ACTIVATED.

RT875CCS HOIST REEVING DIAGRAMS

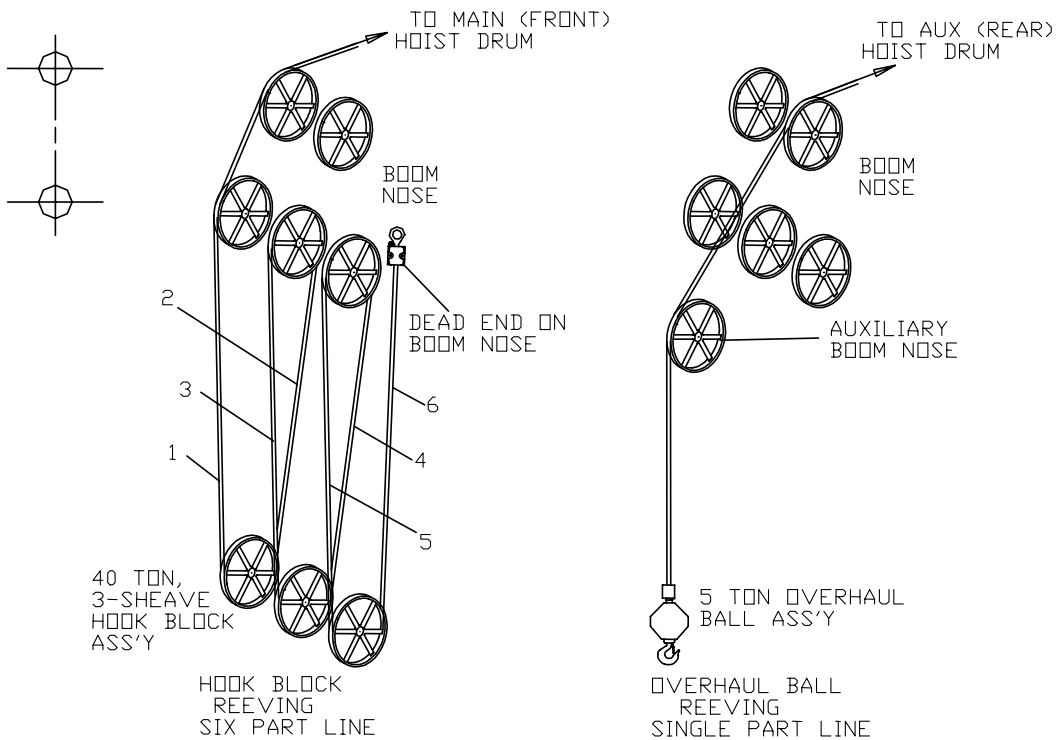

HOISTS	CABLE SPECS	PERMISSIBLE LINE PULLS	NOMINAL CABLE LENGTH
MAIN GROVE MODEL 30	¾ IN. FLEX-X PLUS	13,608 LBS.	500 FT.
AUX. GROVE MODEL 30	¾ IN. FLEX-X PLUS	13,608 LBS.	230 FT.

APPENDIX G

OPERATION AND STOWAGE OF BOTTOM LIFT SLING, 20 FT / 40 FT SELF LEVELING

G-1. INTRODUCTION

This appendix contains equipment description, capabilities and features, equipment data, safety, care and handling instructions, operating instructions, and preventive maintenance procedures for the 20 ft / 40 ft self leveling bottom lift sling.

The operating instructions include steps necessary to remove the spreader bar from its cradle and attach it to the crane's hook block. It also includes procedures for attaching to containers, lifting, pick and carry operations, transporting the bottom lift sling, and also describes how to remove and stow the bottom lift sling.

G-2. PURPOSE OF EQUIPMENT

The 20 ft / 40 ft bottom lift sling is designed for handling of International Standards Organization (ISO) and American National Standards Institute (ANSI) Series 1, freight containers. Military operations include handling, stacking, and the loading and unloading of 20 to 40 foot standard ISO containers at the rated loads worldwide, on hard stand or rough terrain surfaces, in snow, mud, desert, and beach sand environments. The system is used to ground/load containers from/to waiting transportation in the Theater and Corps area for both ammunition units and transportation units used in intermodal (land, rail, air, and marine) service.

A single sling for lifting all length of freight containers conforming to ISO standards. The sling is lighter in weight and stores in a small compact cube making it easily transported when compared to top lift container spreaders. In addition the sling has both transverse and longitudinal manual load leveling capability.

G-3. EQUIPMENT DESCRIPTION, CAPABILITIES, AND FEATURES

G-3.1 Description

The 20 ft / 40 ft bottom lift sling lifts containers by affixing twist lock couplings to the bottom counter fittings of the ISO/ANSI freight containers. The bottom lift sling has a wire rope hoist bridle assembly, a rigid frame, two sets of chains that can be adjusted for container length and leveling, and four twist lock freight container couplings.

The bottom lift sling has four lift lugs which are inserted into the side apertures of the bottom corner of the containers. A transverse lift beam bridges the top of the container to be lifted. Each end of the lift beam has two shortening hooks, to which a chain is connected creating two chain legs of a suitable lengths on each side of the container. The lift lugs previously mentioned are connected to the four chain ends and form a four leg lifting sling.

G-3.2 Capabilities and Features

The 20 ft / 40 ft bottom lift sling is a simple system (ease of use), versatility (one system for both 20 foot and 40 foot containers), and with a 76,200 pounds lift capacity for both 20 foot and 40 foot containers. This economical sling assembly allows the user to lift from the bottom corner fittings and adjust for off-center loads in both longitudinal and transverse directions. It can be adjusted for loaded containers whose center of gravity is 25% away from the center of the container. It is compact and can be stowed onboard the front of the RTCC Model RT875CCS, making it easier to transport to the work sites. Suitable for missions where there are few lift requirements and no high staking or tight space requirements.

G-4. EQUIPMENT DATA

Bottom Lift Sling, 20 Ft / 40 Ft Self Leveling

Manufacturer..... Tandemloc, Inc.
 Model Q2500AA-400
 Weight 1,563 lbs (709 kg)
 Lift Capacity (Containers and Contents)..... 67,200 pounds (30.48 MT)
 Dimensions:
 Length..... 8.35 feet (2.55 m)
 Width..... 16 inches (40.6 cm)
 Height..... 3.7 feet (112.8 cm)
 Operating Temperature..... -25°F to +120°F (-30°C to +480°C)

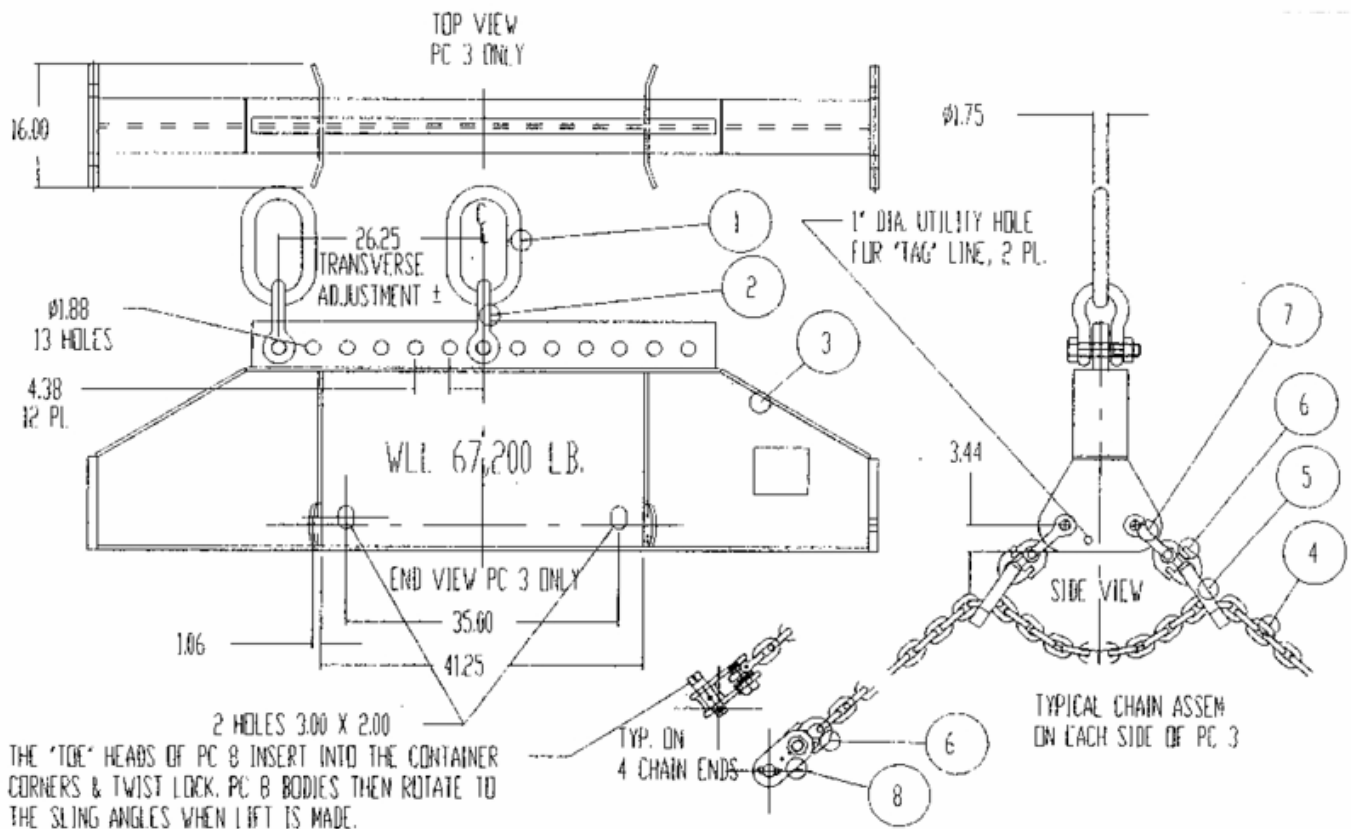

Item	Qty	Nomenclature
1	1	Lift Ring
2.	1	Shackle Bolt, Nut, Cotter Pin
3.	1	Strongback Assembly
4.	2	Chain Length (each 600 feet ±4-inches)
5.	4	Lift Chain Shortening Hooks
6.	8	Alloy Chain Connectors
7.	4	Shackle Bolts, Nuts, Cotter Pin
8.	4	Rotary Lift Lugs

G-4.1 Strongback Assembly (Spreader Bar)

Can be adjusted for off-center loads in longitudinal directions. Side by side leveling can be adjusted by moving the lift lug on top of the strongback toward the heavy side.

G-4.2 Alloy Steel Chain

Two (2) piece set, each 50 foot long (or 45.5 foot). Use to adjust for off-center loads in both longitudinal and transverse directions. It can be adjusted for loaded containers whose center of gravity is 25% away from the center of the container. For load leveling the chain, the chain legs can be manually adjusted to shorten on the heavy end and lengthened on the light end. The top strongback can be adjusted longitudinally more than plus or minus 25% of the container length from the centerline.

G-4.3 Rotating Lift Lugs

The bottom lift sling shall have four identical rotating lift lugs for bottom lifting the container in accordance with ISO 3874, section 6.4. The lift lugs should be designed so that they are twist locked into the container corner fittings while lifting the containers, with the sling cables at the angles specified in ISO 3874, section 6.4, Table 6. The rotating lift lugs are actuated manually by turning the twist locks.

G-5. SAFETY, CARE, AND HANDLING

WARNING

Personnel in the immediate vicinity and personnel participating in operation of the bottom lift sling must be continuously alert to the inherent dangers associated with handling freight containers. The containers are heavy and cumbersome. Personnel on the ground cannot depend on the hoisting equipment operator to be responsible for their safety. The containers are usually stacked in close proximity; therefore, the possibility of being crushed by a swaying container is always present. Failure to exercise adequate safety precautions can result in serious injury or death.

Prior to making lift, ensure all twist locks are securely locked into container.

Do not operate the bottom lift sling in a thunderstorm. Gusty winds, heavy precipitation, and lightning create a hazardous situation for lifting and transporting containers.

Never crawl, stand, or walk beneath the bottom lift sling during operations. The load lifted should never exceed the working load limit (WLL) specified on the bottom lift sling and plate. Personnel should position themselves well clear of this bottom lift sling when in use.

Personnel should never ride on or place any part of themselves under or adjacent to a bottom lift sling and/or the load under lift.

Do not use this bottom lift sling for lifting from the top corners if the container is 20 ft or up sizes. Use equipment for designed use only.

CAUTION

The coupling receptacles (that accepts the rotating lift lugs) on the freight container must also be checked and any mud, dirt, snow, or ice formation removed.

Any modifications or repairs to the bottom lift sling should be made by qualified personnel. If this work is structural, the bottom lift sling should be proof or load tested again.

A low height test lift should be conducted to confirm bottom lift sling function and load stability. The lifted load should be balanced such that excessive point loading does not occur. All lifting should be done in a smooth, even manner to minimize shock to the bottom lift sling and load.

G-6. OPERATING INSTRUCTIONS

Ensure the Preventive Maintenance Checks and Services (PMCS) procedures have been performed on the crane before attempting to remove the bottom lift sling from the stowage cradle, ground storage location, or storage tray that comes with the sling. For attaching the sling from onboard stowage position on the Model RT875CCS see Paragraph G-6.1. For the RTCC Model RT875CC, which does not have the onboard stowage capability, the bottom lift sling should be stored on pallets. This will allow forklifts to be able to load and unload flatbed trailers for transporting the sling to the work site.

G-6.1 Attaching the Bottom Lift Sling to the Crane Hook Block

1. If not installed, install lift shackle and lift ring on bottom lift sling. Inspect lift ring for wear, stress cracks, corrosion, and evidence of stretching. Inspect all sling attachments for gouges, distortion, or elongated throat openings. Check for stress cracks at attachment points.
2. With hook block installed, extend/retract and elevate/lower boom as necessary, while using the hoist to lower the hook block over the bottom lift sling as shown.
3. Attach hook block to lift ring. Ensure safety latch on hook block is closed.
4. If bottom lift sling is installed in crane storage cradle, remove quick release pins (four places) securing bottom lift sling to storage cradle.
5. If container lift chains are installed on bottom lift sling and bottom lift sling is installed in crane storage cradle, unhook chain links from notch in storage box on crane.
6. Take up slack in hook block cable and slowly lift bottom lift sling until it is clear of its storage cradle (or ground/pallet storage). Use care as container lift chains uncoil from storage box. Ensure that chains do not snag or kink.
7. If container lift chains shortening hooks (and chains) are not installed, attach the lift chain

shortening hooks to bottom lift sling with shackles and alloy chain connectors.

8. If container lift chains are not installed, find the center marking of the lift chains and center it between the shortening hooks. Leave at least 24 inches of chain looped between the shortening hooks on each end of the bottom lift sling. The required chain length for either the 20 foot or 40 foot containers and space between container and sling is controlled by the length of the chain loops between the shortening hooks.
9. Slowly lift bottom lift sling straight up while uncoiling the container lift chains. Ensure that chains do not snag or kink as bottom lift sling raises.
10. Inspect the chain links, link by link for wear, bends, cracks, scratches, corrosion, and evidence of stretching. If extreme wear is found, check the stock diameter to ensure it is within service limits.

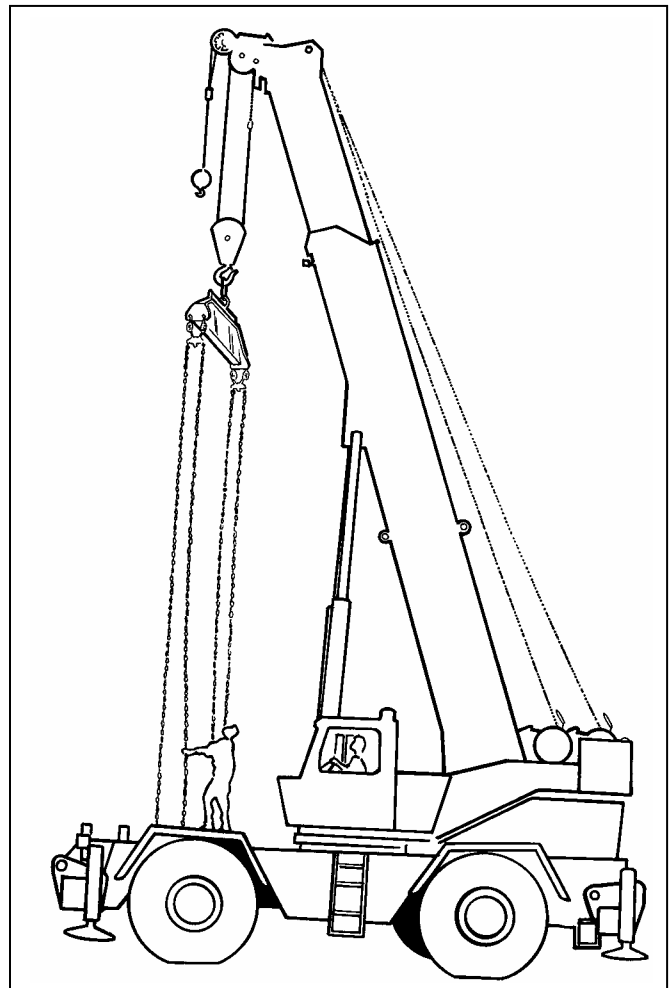

G-6.2 Attaching the Bottom Lift Sling to a Container

1. Using 4 ground guides and tag lines attached to the rotary lift lugs to control rotational movement, lift the bottom lift sling and chains over the container and position the sling across the center of the container.
2. Pull each of the chains and rotary lift lugs to the bottom corner lifting holes of the container. Once the rotary lift lugs are in alignment and inserted, twist the rotary lift lug until it is locked in the lifting holes.
3. When the bottom lift sling is raised for lifting operations, the force of the lifting action will lock the rotary lift lugs in place. When the container is lowered and the rotary lift lugs are at rest, the rotary lift lugs can be turned to the unlocked position and removed.

G-6.3 Lifting a Container with the Bottom Lift Sling

WARNING

Failure to exercise adequate safety precautions can result in serious injury or death.

Do not lift with twisted or kinked chains.

Never attempt to lift a container that is loaded to a gross weight that exceeds the safe working load of the sling.

Be sure that all ground crewmembers are positioned well clear of the container in operation. Personnel in the immediate vicinity and personal participating in the operation of the sling must be continuously alert to the inherent dangers associated with handling containers.

Use a guide rope or tag line to help control container sway.

Lift loads should be done smoothly to minimize shock to the bottom lift sling and load. Shock loading of chain slings results may be the same as overloading.

1. Slowly lift the container as shown. Make a low lift test to check lift function and stability and to see if the container is load leveled sufficiently for the intended purpose.
2. If load leveling adjustments are required, lower the container to slacken the lift leg chain legs. Shorten the two legs on the heavy end equally and length the legs on the light end equally. This may have to be done several times to achieve a sense of how much to adjust.

NOTE

Note that legs on each end should be of equal length and that the lift angles must conform to the noted data.

Both lift angle (A + B) should not be less the 90° and each lift angle (A or B) should not be less the 30°, individually.

3. If the container does not lift level set the container down and adjust the length of chain legs by shortening the legs on the heavy end and lengthen the legs on the light end. Make sure you adjust the same number of links on both chains. The chains are marked with a color band every ____ links. Always leave slack in chain length that ends up between the two lift chain shortening hooks to allow the two hooks to swing to their natural use angle. Adjust side to side leveling by moving the lifting ring on top of the bottom lift sling strongback toward the heavy side.

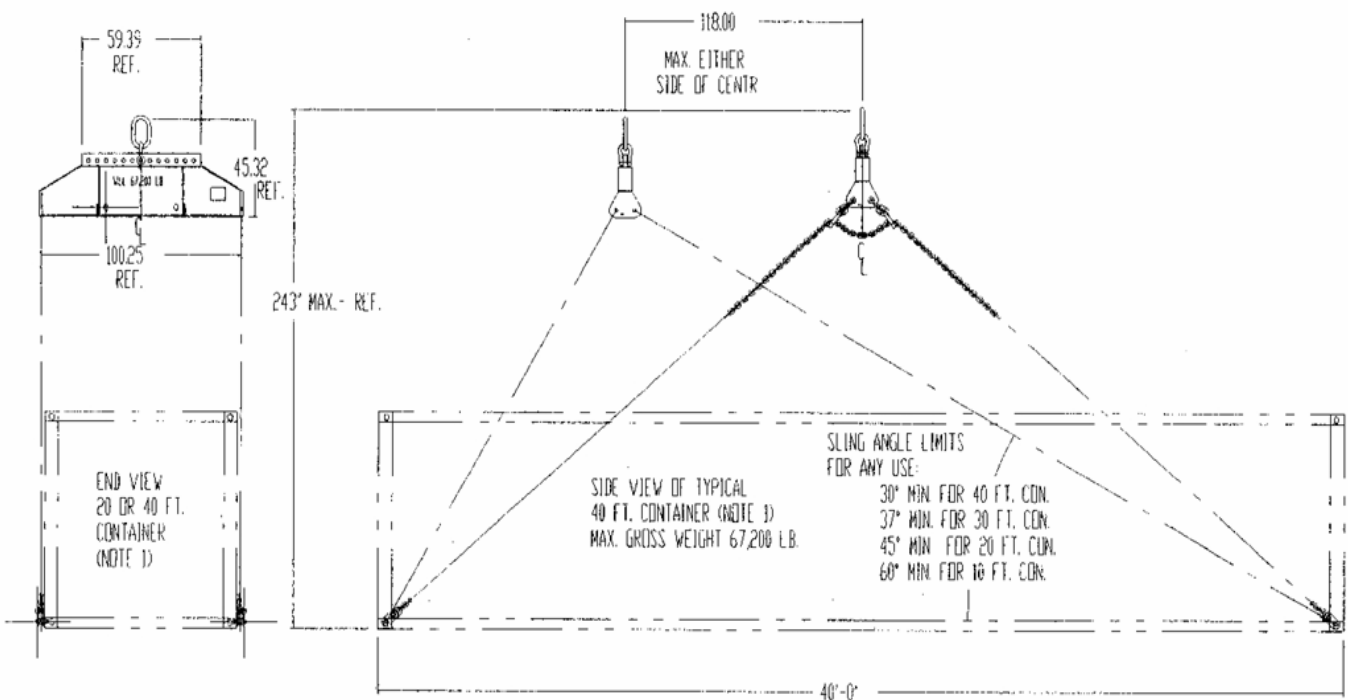
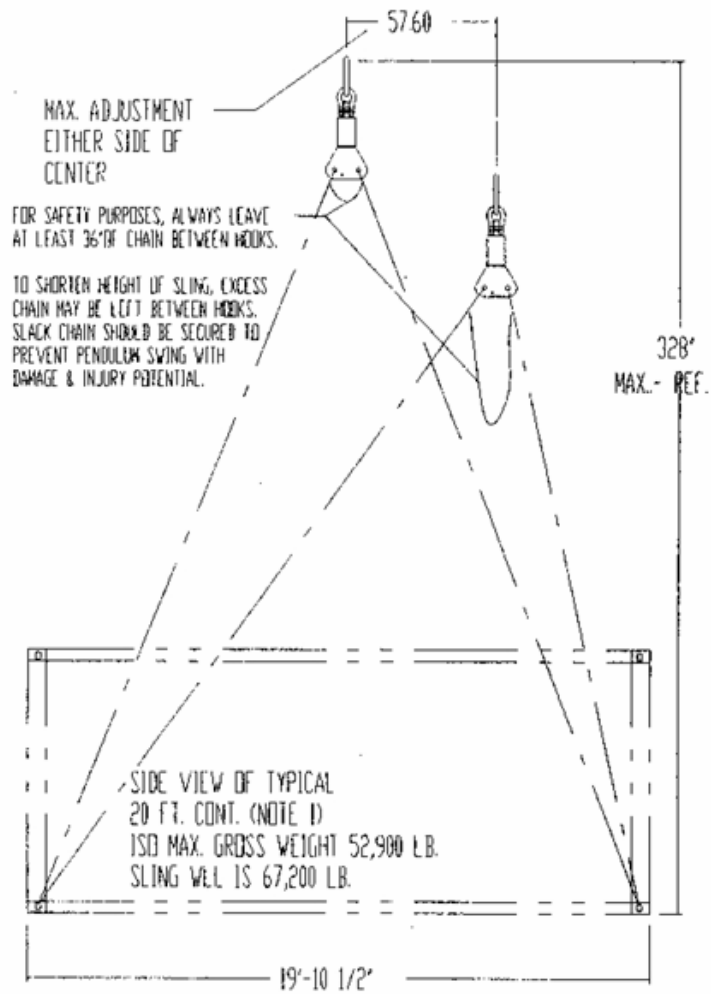

G-6.4 Pick and Carry on Rubber

WARNING

If not required for an on-rubber lift, the bottom lift sling must be removed from its on crane stowage cradle for ALL on rubber lifts.

Because the crane's on-rubber capacity is based on using the maximum axle capacity, the addition of the bottom lift sling to the crane DOES impact the crane's overall on-rubber capacity, including pick and carry capacity. The bottom lift sling MUST be removed from the stowage position whenever on-rubber lifts are made. If the bottom lift sling is in use for on-rubber handling of containers, it's weight is suspended from the hook and must be considered part of the load being lifted. If the bottom lift sling is not being used for handling of containers, it should be removed from the crane when making on-rubber lifts. Otherwise, it's weight acts to increase the live axle load without that weight being taken into effect by the LMI.

G-6.5 Stowing the Bottom Lift Sling in Crane Storage Cradle (RT875CCS)

1. Extend/retract and elevate/lower boom as necessary, while using hoist to place the spreader bar directly over the spreader bar stowage cradle with container lift chains extended as shown.
2. Use the hoist to slowly lower the spreader bar while assistants lay the container lift chains in the storage box between the two front fenders. If necessary, catch a link of the chain in the notch provided in the storage box. This will prevent the chain from running out of the box.
3. Continue to lower the spreader bar until it rests in the cradle as shown. Use assistants as necessary to guide spreader bar into its rest.
4. If necessary, detach container lift chains.
5. Slowly lower hook block to produce slack in hoist cable to allow spreader bar to rotate forward onto its attachment pins. Use assistants to guide spreader bars if necessary to engage pins.

6. Install quick release pins (four places) to secure spreader bar in place.
7. Unhook the hook block from spreader bar lift ring. Then slowly raise hook block as required to clear the work area.

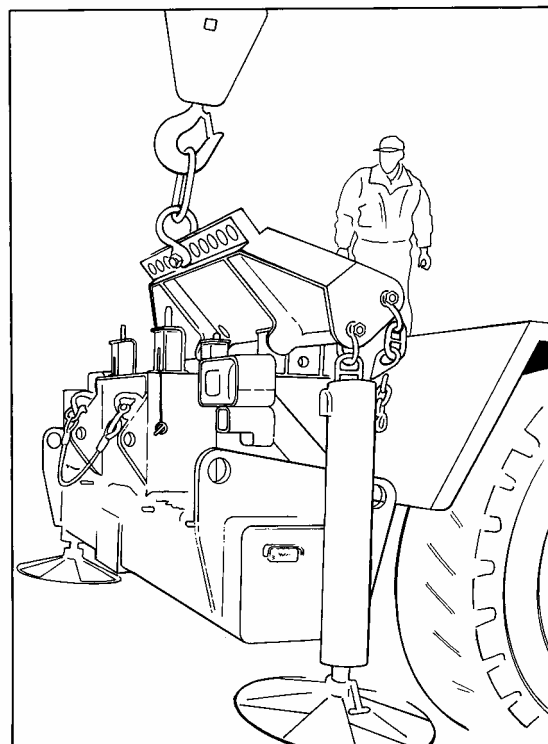
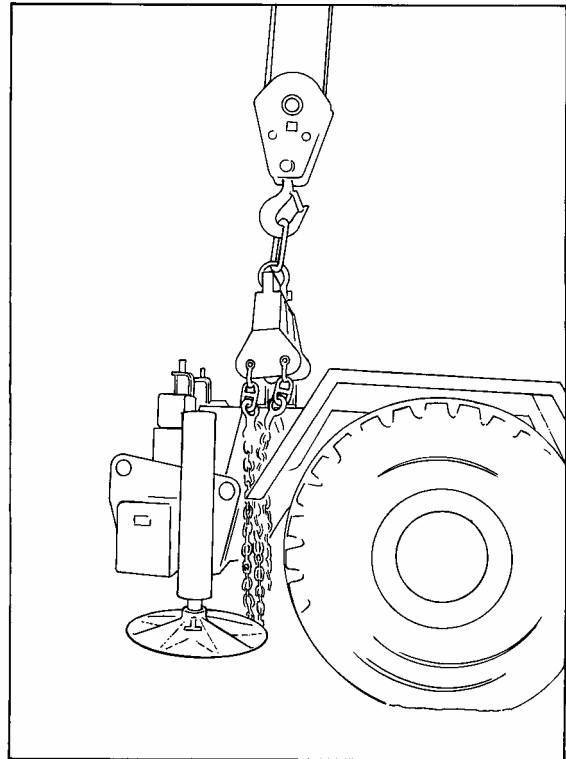

G-6.6 Stowing the Bottom Lift Sling in Stowage Tray (RT875CC)

1. Extend/retract and lower the crane boom as necessary to place the bottom lift sling directly into the storage tray that was provided with the sling. The stowage will reduce storage space and can be used to for transporting the sling assembly. Secure the bottom lift sling and chains in the stowage tray as shown.

G-6.7 Transporting the Bottom Lift Sling

1. For installation highway travel and mission operational use the sling can be transported on the RTCC Model RT875CCS in it stowage position on the crane storage cradle. If the RTCC RT875CCS is to be transported by another mode of travel (trailer, commercial lowboy, rail, or air) by over limits transportation routing or by disassembly, the bottom lift sling, must be removed and shipped separately. The bottom lift sling can be shipped in the stowage tray that was provided with the sling.

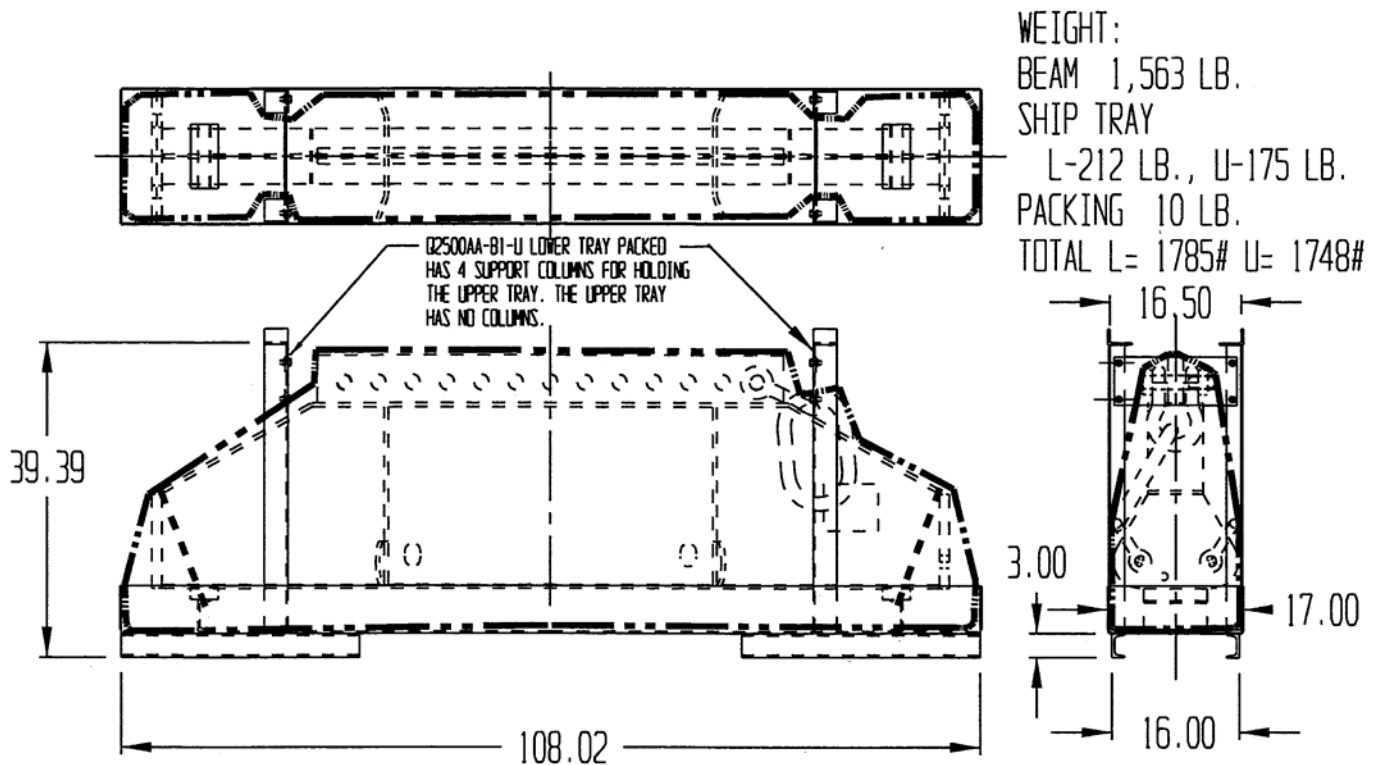

G-7. PREVENTIVE MAINTENANCE

When you do preventive maintenance take along a rag as you will always need at least one.

WARNING

DRY CLEANING SOLVENT P-D-680, Type III IS TOXIC AND FLAMMABLE. Wear protective goggles and gloves and use only in a well-ventilated area. Avoid contact with skin, eyes, and clothes and do not breathe vapors. Do not use near open flame or excessive heat. Flash point is 200° F (94° C). If you become dizzy while using DRY cleaning solvent, get fresh air immediately and get medical aid. If solvent contacts eyes, wash your eyes and get medical aid immediately.

G-7.1 Preventive Maintenance Procedures

1. Keep it clean: Dirt, grease, oil, and debris only get in the way and may cover up a serious problem. Clean as you work and as needed. Use dry cleaning solvent (SD2) on all metal surfaces. Use soap and water when you clean rubber or plastic material.
2. Bolts, nuts, and screws: Check them all for obvious looseness, missing, bent or broken conditions. You can't try them all with a tool, of course, but look for chipped paint, bare metal, or rust around the bolt heads. If you find one you think is loose, tighten it. Report it to Unit Maintenance, before operation.
3. Bottom Lift Sling Strongback Frame: Check for bends, cracks, broken welds.
4. Chains: check for cracks, bent links, corrosion pits, gouges, distortions and elongated openings.. The chain size is " " and should be removed form service is the dimensions equal " " .
5. Rotary Lift Lugs: check for broken or cracked twist locks. Check to see that they rotate from unlock to lock positions. All twist locks must rotate a full 1/4 turn.

6. This bottom lift sling should be reproof tested and recertified every 24 months or after 1000 uses, whichever occurs first.

G-7.2 Rated Load Test

This item should be reproof tested and recertified every 24 months or after 1000 uses, whichever occurs first. With the bottom lift sling, pick up a load equal to 125% (ref. ASME B30.20-1999, Paragraph 20-1.4.2 or TB -----) of the rated payload, uniformly distributed over the pick-up points, to a height of 2 feet. Hold for 5 minutes. Lower load and disengage the bottom lift sling. Examine the bottom lift sling and container for failures, cracks, deformation, inoperability, or other defects. Any evidence of permanent deformation shall be cause for rejection of the sling leg assembly.

G-7.3 Tools

All nonstandard or special tools required for operation and maintenance of the bottom lift sling shall be furnished.

APPENDIX H

TRANSPORTABILITY GUIDANCE

H-1. PREPARATION FOR SHIPMENT

1. Also refer to Chapter 18, TM 5-3810-306-20 - "Preparation for Storage or Shipment".
2. **NOTE** – Crane is oversize for all modes of shipments.
3. For highway transport, check state and local laws governing weight, width, and length of load.

WARNING

Check travel for overpass and bridge clearances. If clearances are not adequate, an accident causing injury or death to personnel or damage to equipment could result.

4. Reference --TGTM----- TM 55-3810-306-15 for transportability data necessary for transporting the RTCC by highway, rail, marine, and air modes of transport. The RTCC is capable of sectionalization into two major components (superstructure and chassis). Refer to TM 5-3810-306-34.
5. Reference the Pamphlets
 - a. Pamphlet No. 55-19, Tie Down Handbook for Rail Movement.
 - b. Pamphlet No. 55-22, Marine Lifting and Lashing Handbook.
 - c. Pamphlet No. 55-19, Transportability for highway.

H-2. MILITARY LOAD CLASSIFICATION (MLC)

1. Reference STANAG 2021, Military Computation of Bridge, Ferry, Raft, and Vehicle Classification.
2. Reference STANAG 2010, Military Load Classification Markings.
3. The MLC and loading data is given for the follow models.
 - a. Empty (Travel Weight) – RT875CC
 - Gross Weight: 94,500 lbs
 - Front Axle: 16,783 kg (18.5 tons)
 - Rear Axle: 26,671 kg (29.4 tons)
 - Width at Tires: 3.65 m (12 ft)
 - Axle Spacing: 4.32 m (14 ft 2 in)

MLC: 85
 - b. Empty (Travel Weight) – RT875CCS
 - Gross Weight: 97,325 lbs (with Bottom Lift Sling)
 - Gross Weight: 95,800 lbs (without Bottom Lift Sling)
 - Front Axle: 16,783 kg (18.5 tons)
 - Rear Axle: 26,671 kg (29.4 tons)
 - Width at Tires: 3.65 m (12 ft)
 - Axle Spacing: 4.32 m (14 ft 2 in)

MLC: 87

H-3. BOTTOM LIFT SLING

Due to highway requirement of non-permanently attached components and items, the bottom lift sling must be removed from the on board storage cradle and shipped separately in the stowage tray provided with the bottom lift sling (Appendix G, this manual).

ALPHABETICAL INDEX

Page No.

A

Accessory Items Maintenance	3-21
Additional Authorization List (AAL)	C-1
Air Cleaner Assembly Maintenance	3-18
Air Reservoir Service	3-20
Automatic LMI Setup	2-47

B

Basic Issue Items (BII) List	B-4
Before Turning on Ignition Switch	2-33
Boom Inspection	3-22
Boom Operating Procedures, Emergency	2-59
Boom Service	3-22
Boom, Raising and Lowering	2-53
Boom, Swinging the	2-52
Boom, Telescoping (Extending)	2-53
Bottom Lift Sling, Operation and Stowage of	G-1

C

Cab Heater (RT875CC)	2-56
Cab Heater (RT875CCS)	2-55
Cab Heater Fuel Tank Maintenance	3-21
Cab Heater/Defroster Maintenance	3-21
Changing LMI Settings During Operation (RT875CCS)	2-48
Characteristics, Capabilities and Features, Equipment	1-2
Cold Weather Operation	2-57
Cold Weather Starting	2-57
Components of End Item (COEI) List	B-2
Control Panel Controls and Indicators	2-2
Cooling System Maintenance	3-19
Crane Functions	2-50
Crane Misuse	2-42
Craning Operations	2-37
Electrical Hazards	2-40
Ensuring Crane Is Stable	2-40
Establishing a Signal Person	2-37
General Safety Precautions	2-37
Initial Lifting Loads	2-45
Normal Craning Operation	2-49
Planning and Set Up	2-42
Preload Check	2-45
Programming LMI For Normal Operation (RT875CC)	2-49
Programming LMI For Normal Operation (RT875CCS)	2-46
Using Your Load Chart	2-44
Wire rope and Sheaves Safety Precautions	2-39

C - Continued

Crane Travel Operation	2-34
Four-Wheel Drive Operation	2-36
Moving the Crane - Forward	2-36
Moving the Crane In Reverse	2-36
Parking	2-37
Preparation For Travel	2-34
Steering.....	2-35
Travel Safety Precautions	2-35
Craning Operation, Normal	2-49

D

Data Equipment	1-6
Stowage and Sign Guide	E-1
Decals	E-1
Signs	E-1
Description and Location of Major Components	1-5
Description and Use of Operator's Controls and Indicators	2-1
Control Panel Controls and Indicators	2-2
Load Moment Indicator (RT875CC)	2-12
Load Moment Indicator (RT875CCS)	2-8
Display Contrast Control	2-49
Displaying System Information	2-49
Door Assembly With Latch/Handle Maintenance	3-21

E

Electrical Hazards	2-41
Electrical System Maintenance	3-19
Emergency Boom Operating Procedures	2-59
Emergency Load Lowering Procedure (RT875CC)	2-61
Emergency Starting	2-58
Emergency Stowage Procedure (RT875CCS)	2-59
Engine Inspection	3-18
Engine Operation.....	2-33
Shutdown Procedure	2-34
Starting Procedure	2-33
Ensuring Crane Is Stable.....	2-40
Equipment Characteristics, Capabilities and Features	1-2
Equipment Data	1-6
Equipment Improvement Recommendation (EIR), Reporting.....	1-1
Equipment Improvement Report and Maintenance Digest (EIR.MD)	1-1
Error Codes, Load Moment Indicator (LMI) System	3-16
Establishing a Signalperson	2-37
Exhaust System Muffler and Pipes Maintenance	3-19
Expendable Supplies and Materials List.....	D-1

F

Fenders and Rear Decking Installation Maintenance	3-21
Fire Extinguisher Maintenance	3-21

F - Continued

Four Wheel Drive Operation	2-36
Front Console Maintenance	3-21
Fuel Supply Maintenance	3-18

G

General Safety Precautions	2-32
General Safety Precautions, Crane Operations	2-37
Guides and Roller Maintenance.....	3-22

H

Hoist Cable, Lowering and Raising	2-54
Hood Assembly Maintenance	3-21
Hook Block Inspection	3-22
Hook Block Service	3-22
Hydraulic Fluid Cooler Maintenance.....	3-20
Hydraulic System Maintenance	3-21

I, J, K

Initial Lifting Loads	2-46
-----------------------------	------

L

Lifting Loads, Initial	2-45
Lifting On Rubber	2-58
Lifting On Rubber, Programming LMI For	2-58
Load Chart, Using Your	2-43
Load Lowering Procedure, Emergency	2-61
Load Moment Indicator (LMI) System Error Codes	3-16
Load Moment Indicator (LMI) System Maintenance	3-22
Load Moment Indicator (RT875CC) (Controls and Indicators)	2-12
Load Moment Indicator (RT875CCS) (Controls and Indicators).....	2-8
Load Moment Indicator (RT875CC) (Programming for Operation)	2-49
Load Moment Indicator (RT875CCS) (Programming for Operation)	2-46
Location and Description of Major Components	1-5
Lowering and Raising Boom	2-53
Lowering and Raising Hoist Cable	2-54

M

Maintenance Forms, Records and Reports	1-1
Maintenance Procedures.....	3-18
Air Reservoir Service	3-20
Body, Cab, Hood, and Hull	3-21
Body, Chassis, or Hull and Accessory Items	3-21
Crane Attachments	3-22
Electrical System	3-19
Engine Inspection and Service	3-18
Frame.....	3-20
Fuel.....	3-18
Hydraulic Fluid Cooler.....	3-20

M - Continued

Maintenance Procedures – Continued

Hydraulic System	3-21
Introduction	3-18
Load Moment Indicator (LMI) System	3-22
Steering System.....	3-20
Tires	3-20
Transmission Service.....	3-20
Major Components, Location and Description of	1-5
Moving The Crane - Forward	2-36
Moving the Crane In Reverse	2-36

N

Normal Craning Operation	2-49
--------------------------------	------

O

On Rubber, Lifting	2-48
Operating Procedures, Emergency Boom	2-59
Operation Under Unusual Conditions	2-57
Operation Under Usual Conditions	2-32
Operation, Cold Weather	2-57
Operations, Pick and Carry	2-59
Operator Preventive Maintenance Checks and Services (PMCS).....	2-16
Operator’s Controls and Indicators, Description and Use of	2-1
Outriggers Maintenance	3-20
Outriggers, Setting the.....	2-50
Outriggers, Stowing	2-51

P

Parking	2-37
Parking and Stowing.....	2-55
Pick and Carry Operations.....	2-59
Planning and Setup, Crane Operation	2-42
Preload Check	2-45
Preparation For Travel.....	2-34
Preparation For Use/Service Upon Receipt	2-33
Preventive Maintenance Checks and Services (PMCS), Operator.....	2-16
Programming LMI For Normal Operation (RT875CCS).....	2-46
Programming LMI For Lifting On Rubber (RT875CC)	2-58
Programming LMI For Lifting On Rubber (RT875CCS)	2-58
Programming LMI For Normal Operation (RT875CC)	2-49
Purpose of Equipment	1-1

Q, R

Raising and Lowering Boom.....	2-53
Raising and Lowering Hoist Cable	2-54
Reporting Equipment Improvement Recommendations (EIR)	1-1

Q, R - Continued

References	A-1
Department of the Army Pamphlets	A-1
Field Manuals.....	A-1
Forms.....	A-1
Other Publications.....	A-2
Specifications and Standards	A-2
Technical Bulletins	A-2
Technical Manuals	A-2

S

Safety Precautions, General	2-32
Safety Precautions, Travel.....	2-35
Safety Precautions, Wire Rope and Sheaves	2-39
Scope	1-1
Seat Assembly Maintenance	3-21
Setting LMI Limits (RT875CCS).....	2-48
Setting The Outriggers	2-50
Shutdown Procedure, Engine	2-34
Signalperson, Establishing A	2-37
SLEP Modifications, (Explanation of).....	1-2
Starting Procedure, Engine.....	2-33
Starting, Cab Heater (RT875CC)	2-56
Starting, Cab Heater (RT875CCS)	2-55
Starting, Cold Weather	2-57
Starting, Emergency	2-58
Steering System Maintenance.....	3-20
Stopping, Cab Heater (RT875CC)	2-56
Stopping, Cab Heater (RT875CCS)	2-56
Stowing and Parking.....	2-55
Stowing Outriggers	2-51
Swing System Test	3-22
Swinging the Boom	2-52

T

TARE, Displaying	2-49
Technical Principles of Operation	
Air System.....	1-12
Electrical System	1-12
Hydraulic System	1-11
Introduction	1-11
PAT/LMI System	1-12
Steering System.....	1-12
Telescoping (Extending) Boom	2-53
Tires Maintenance	3-20
Towing	2-64
Transmission Service	3-20
Transportability Guidance.....	H-1
Travel Operation, Crane	2-34
Travel Safety Precautions.....	2-35

T - Continued

Travel, Preparation For	2-34
Troubleshooting Procedures	
Brakes	3-11
Cab Heater.....	3-15
Cooling System	3-8
Electrical System	3-10
Engine	3-3
Hydraulic System	3-11
Load Moment Indicator (LMI).....	3-16
Steering	3-11
Transmission	3-10

U,V,W,X,Y,Z

Use/Service Upon Receipt, Preparation For	2-33
Using Your Load Chart	2-44
Warranty Information.	1-1
Wire Rope and Sheaves Safety Precautions.....	2-39

By Order of the Secretary of the Army:

Official:



JOYCE E. MORROW

*Administrative Assistant to the
Secretary of the Army*

0703110

PETER J. SCHOOMAKER
*General, United States Army
Chief of Staff*

Distribution:

To be distributed in accordance with the initial distribution number (IDN) 255977,
requirements for TM 5-3810-306-10.

RECOMMENDED CHANGES TO PUBLICATIONS AND BLANK FORMS For use of this form, see AR 25-30; the proponent agency is ODISC4.						Use Part II (<i>reverse</i>) for Repair Parts and Special Tool Lists (RPSTL) and Supply Catalogs/Supply Manuals (SC/SM).	DATE
TO: (<i>Forward to proponent of publication or form</i>) (<i>Include ZIP Code</i>) AMSTA-LC-LPIT / TECH PUBS, TACOM-RI 1 Rock Island Arsenal Rock Island, IL 61299-7630						FROM: (<i>Activity and location</i>) (<i>Include ZIP Code</i>)	
PART I - ALL PUBLICATIONS (EXCEPT RPSTL AND SC/SM) AND BLANK FORMS							
PUBLICATION/FORM NUMBER TM 5-3810-306-10						DATE 28 February 2007	TITLE Container Crane, 40 Ton, Rough Terrain, Models RT875CC and RT875CCS
ITEM NO.	PAGE NO.	PARA-GRAPH	LINE NO. *	FIGURE NO.	TABLE NO.	RECOMMENDED CHANGES AND REASON (<i>Provide exact wording of recommended changes, if possible.</i>)	
<i>*Reference to line numbers within the paragraph or subparagraph.</i>							
TYPED NAME, GRADE OR TITLE				TELEPHONE EXCHANGE/AUTOVON, PLUS EXTENSION		SIGNATURE	

TO: <i>(Forward direct to addressee listed in publication)</i> AMSTA-LC-LPIT / TECH PUBS, TACOM-RI 1 Rock Island Arsenal Rock Island, IL 61299-7630	FROM: <i>(Activity and location) (Include ZIP Code)</i>	DATE
--	---	------

PART II - REPAIR PARTS AND SPECIAL TOOL LISTS AND SUPPLY CATALOGS/SUPPLY MANUALS

PUBLICATION NUMBER TM 5-3810-306-10	DATE 28 February 2007	TITLE Container Crane, 40 Ton, Rough Terrain, Models RT875CC and RT875CCS
--	--------------------------	---

PAGE NO.	COLM NO.	LINE NO.	NATIONAL STOCK NUMBER	REFERENCE NO.	FIGURE NO.	ITEM NO.	TOTAL NO. OF MAJOR ITEMS SUPPORTED	RECOMMENDED ACTION

PART III - REMARKS *(Any general remarks or recommendations, or suggestions for improvement of publications and blank forms. Additional blank sheets may be used if more space is needed.)*

TYPED NAME, GRADE OR TITLE	TELEPHONE EXCHANGE/AUTOVON, PLUS EXTENSION	SIGNATURE
----------------------------	--	-----------

